

# eTOP500 Glass Series

## Operating Instructions



Copyright © 2015-2018 Exor International S.p.A. – Verona, Italy  
Subject to change without notice

The information contained in this document is provided for informational purposes only. While efforts were made to verify the accuracy of the information contained in this documentation, it is provided “as is” without warranty of any kind.

Third-party brands and names are the property of their respective owners.

[www.exorint.com](http://www.exorint.com)



# Table of Contents

Introduction	4
1 Product Overview	6
2 Standards and Approvals	7
3 Technical Specifications	9
4 Technical Data	11
4.1 Dimensions	13
4.2 Installation Environment	16
4.3 Safety instruction	17
4.4 Installation Procedure	17
5 Connections	18
5.1 Serial Port	20
5.2 Ethernet Port	20
5.3 Optional plugin module	21
5.4 Optional plugin module identification	22
5.5 Optional plugin module installation procedure	23
6 Power Supply, Grounding and Shielding	25
7 Battery	26
8 Special Instruction for Use	27
9 Getting Started	27
10 System Settings	28
11 Unpacking and Packing Instructions	31

# Introduction

The operational guidelines described below is information which relates to the device, installation, transportation, storage, assembly, use and maintenance.

This Operating Instruction describes the main features of the Exor operator panels. The Manual refers to the following models:

eTOP507G	Operator interface with TFT color 7" widescreen display touchscreen
eTOP507MG	Operator interface with TFT color 7" widescreen display touchscreen, 1GHz CPU
eTOP510G	Operator interface with TFT color 10.1" widescreen display touchscreen
eTOP515G	Operator interface with TFT color 15" display touchscreen

# Safety Guide

The manual contains safety standards that must be respected for the personal safety and to avoid damage. Indications of attention are divided into three levels of severity:

DANGER: indicates a failure to observe safety rules and such failure may cause death or serious injuries.



ATTENTION: indicates a failure to observe safety rules and that deficiency may cause damage.



CAUTION: indicates a failure to observe safety rules and that deficiency may cause defects to the equipment or inconsistencies.



# 1 Product Overview

The Exor eTOP Series 500 Glass HMI products combine state-of-the-art features and top performance with an outstanding design. They are the ideal choice for all demanding HMI applications including factory energy and marine applications.

The eTOP Series 500 Glass features a high-brightness, contrast-enhanced ruggedized TFT display with a fully dimmable LED backlight. The product has been designed for use in harsh environments and outdoor applications. Glass bonding assembly and anti-reflective (AR) glass surface treatment provide for superior optical performance. The durable glass touchscreen requires the human touch, eliminating false activations, and offers high reliability and durability; it will continue to work even surface is scratched or contaminated.

The eTOP Series 500 Glass HMI panels have been designed to run the JMobile software.

- Designed for use with JMobile HMI software.
- Full vector graphic support. Native support of SVG graphic objects. Transparency and alpha blending.
- Full object dynamics: control visibility and transparency, move, resize, rotate any object on screen. Change properties of basic and complex objects.
- TrueType fonts.
- Multilanguage applications. Easily create and manage your applications in multiple languages to meet global requirements. Far East languages are supported. Tools available in JMobile Studio support easy third-party translations and help reducing development and maintenance costs of the application.
- Data display in numerical, text, bargraph, analog gauges and graphic image formats.
- Rich set of state-of-the-art HMI features: data acquisition, alarm handling, scheduler and timed actions (daily and weekly schedulers, exception dates), recipes, users and passwords, RSS feeds, rotating menus.
- Includes support for a wide range of communication drivers for Factory systems.
- Multiple drivers communication capability.
- Remote monitoring and control. Client-Server functionality.
- Remote maintenance and support with VNC-based functionality.
- On-line and Off-line simulation with JMobile Studio.
- Powerful scripting language for automating HMI applications. Script debugging improves efficiency in application development.
- Rich gallery of vector symbols and objects.
- Optional plug-in modules for fieldbus systems, I/O and controllers.
- Display backlight dimmable to 0%.

## 2 Standards and Approvals

The products have been designed for use in an industrial environment in compliance with the 2014/30/EU EMC Directive.

The products have been designed in compliance with:

EN 61000-6-4                      EN 55011 Class A

EN 61000-6-2                      EN 61000-4-2  
     EN 61000-4-3  
     EN 61000-4-4  
     EN 61000-4-5  
     EN 61000-4-6  
     EN 61000-4-8

EN60945

IECEX	IECEX: IECEX ULD 16.0007X
IEC 60079-0, Ed.6	Ex nA IIC T4 Gc
IEC 60079-15, Ed.4	Ex tc IIIC T105°C Dc
IEC 60079-31, Ed.2	

ATEX	DEMKO 16 ATEX 1683X
EN 60079-0: 2012+A11:2013	II 3G Ex nA IIC T4 Gc
EN 60079-15: 2010	II 3D Ex tc IIIC T105°C Dc
EN 60079-31: 2014	



The installation of these devices into the residential, commercial and light-industrial environments is allowed only in the case that special in measures are taken in order to ensure conformity to EN 61000-6-3.

The products are in compliance with the Restrictions on Certain Hazardous Substances (RoHS) Directive 2011/65/EU

In compliance with the above regulations the products are CE marked.

# 2 Standards and Approvals

## Product Identification

The product may be identified through a plate attached to the rear cover. You will have to know the type of unit you are using for correct usage of the information contained in the guide.

An example of this plate is shown in the figure below:

Note: the eTOP507G label is used as an example for eTOP500 Glass Series



product model name	eTOP507G
product part number	ETOP507U5P1
year/week of production	1816
serial number	AA00001L7000000561AA
version id of the product	041315A15011000
manufacturer address	Exor International S.p.A. Via Monte Fiorino 9 IT-37057 San Giovanni Lupatoto (VR)
ATEX Marking	DEMKO 16 ATEX 1683X  II 3G Ex nA IIC T4 Gc II 3D Ex tc IIIC T105°C Dc
IECEX Marking IECEX:	IECEX ULD 16.0007X Ex nA IIC T4 Gc Ex tc IIIC T105°C Dc



## 3 Technical Specifications

<b>Touchscreen technology</b>	Projected capacitive	
<b>Back-up battery</b>	3V 50mAh Lithium, rechargeable, not user-replaceable, model VL2330.	
<b>Fuse</b>	Automatic	
<b>Serial Port</b>	RS-232, RS-485, RS-422 software configurable	
<b>Flash</b>	128MB for eTOP507G, 256MB for eTOP507MG, eTOP510G, eTOP515G	
<b>RAM</b>	256MB	
<b>Hardware clock</b>	Clock/Calendar with back-up battery	
<b>Accuracy RTC (at 25°C)</b>	<100ppm	
<b><i>Environmental conditions</i></b>		
<b>Operating temperature (surrounding air temperature)</b>	-20 ÷ +60°C (vertical installation) -20 ÷ +50°C (horizontal installation) Plug-in modules and USB devices may limit max temperature to +50°C	EN 60068-2-14
<b>Storage temperature</b>	-40 ÷ +85°C	EN 60068-2-14
<b>Operating and storage humidity</b>	5 ÷ 85 % RH not-condensing	EN 60068-2-30
<b>Vibrations</b>	5 ÷ 9 Hz, 7 mm <sub>p-p</sub> 9 ÷ 150 Hz, 1 g	EN 60068-2-6
<b>Shock</b>	± 50 g, 11 ms, 3 pulses per axis	EN 60068-2-27
<b>Protection class</b>	Front panel IP69, Rear IP20	EN 60529
<b><i>Electromagnetic Compatibility (EMC)</i></b>		
<b>Radiated disturbance test</b>	Class A	EN 55011 EN 61000-4-2
<b>Electrostatic discharge immunity test</b>	8 kV (air electrostatic discharge) 4 kV (contact electrostatic discharge)	EN 61000-4-2
<b>Radiated, radio-frequency, electromagnetic field immunity test</b>	80 MHz ÷ 1 GHz, 10V/m 1,4 GHz ÷ 2 GHz, 3 V/m 2 GHz ÷ 2.7 GHz, 1 V/m	EN 61000-4-3
<b>Burst immunity test</b>	± 2 KV dc power port ± 1 KV signal line	EN 61000-4-4
<b>Surge immunity test</b>	± 0,5 KV dc power port (line to earth) ± 0,5 KV dc power port (line to line) ± 1 KV signal line (line to earth)	EN 61000-4-5
<b>Immunity to conducted disturbances induced by radiofrequency field</b>	0.15 ÷ 80 MHz, 10V	EN 61000-4-6

## 3 Technical Specifications

### **Voltage dips, short interruptions and voltage variations immunity test**

Port: AC mains; Level:	
100% duration:	1 cycle and 250 cycles (50Hz); 1 cycle and 300 cycles (60Hz);
40% duration:	10 cycles (50Hz);
70% duration:	25 cycles (50Hz);
Phase: 0°-180°	

Test executed on the 230Vac side of the Exor International S.p.A. Power Supply      EN 61000-4-11

### ***Durability information***

#### **Backlight service life (LED type)**

40000 Hrs. or more  
(Time of continuous operation until the brightness of the backlight reaches 50% of the rated value when the surrounding air temperature is 25°C) - see Note 1

Note 1: Extended use in environments where the surrounding air temperature is 40°C or higher may degrade backlight quality/reliability/durability.

## 4 Technical Data

Model	eTOP507G	eTOP507MG
<b>Display / Backlight</b>	TFT Color / LED	TFT Color / LED
<b>Colors</b>	64K	64K
<b>Resolution</b>	800x480	800x480
<b>Diagonal (inches)</b>	7" widescreen	7" widescreen
<b>Dimming</b>	yes	yes
<b>Flash</b>	128MB	128MB
<b>SD card slot</b>	yes	yes
<b>RAM</b>	256MB	256MB
<b>Serial Port</b>	RS-232,RS-485, RS-422 software configurable	RS-232,RS-485, RS-422 software configurable
<b>Ethernet port</b>	2 10/100Mb with integrated switch	2 10/100Mb with integrated switch
<b>USB port</b>	2 Host interface, 1 version 2.0, 1 version 2.0 and 1.1	2 Host interface, 1 version 2.0, 1 version 2.0 and 1.1
<b>Expansion slot</b>	2 Optional Plugin	2 Optional Plugin
<b>Battery</b>	rechargeable	rechargeable
<b>Real Time Clock</b>	yes	yes
<b>Voltage</b>	24Vdc (*)	24Vdc (*)
<b>Current rating (at 24VDC)</b>	0.8A	0.9A
<b>Weight</b>	1 Kg	1 Kg

(\*) 10-32Vdc

For applications requiring compliance with EN 61131-2 and specifically in reference to 10 ms voltage dips, the power supply range voltage is 18-32Vdc.

Model	eTOP510G	eTOP515G
<b>Display / Backlight</b>	TFT Color / LED	TFT Color / LED
<b>Colors</b>	64K	64K
<b>Resolution</b>	1280x800	1024x768
<b>Diagonal (inches)</b>	10.1" widescreen	15"
<b>Dimming</b>	yes	yes
<b>Flash</b>	256MB	256MB
<b>SD card slot</b>	yes	yes
<b>RAM</b>	256MB	256MB
<b>Serial Port</b>	RS-232,RS-485, RS-422 software configurable	RS-232,RS-485, RS-422 software configurable
<b>Ethernet port</b>	2 10/100Mb with integrated switch	2 10/100Mb with integrated switch
<b>USB port</b>	2 Host interface, 1 version 2.0, 1 version 2.0 and 1.1	2 Host interface, 1 version 2.0, 1 version 2.0 and 1.1
<b>Expansion slot</b>	2 Optional Plugin	2 Optional Plugin
<b>Battery</b>	rechargeable	rechargeable
<b>Real Time Clock</b>	yes	yes
<b>Voltage</b>	24Vdc (*)	24Vdc (*)
<b>Current rating (at 24VDC)</b>	1.00A	1.40A
<b>Weight</b>	1.7 Kg	4 Kg

(\*) 10-32Vdc

For applications requiring compliance with EN 61131-2 and specifically in reference to 10 ms voltage dips, the power supply range voltage is 18-32Vdc.

# 4 Technical Data

## 4.1 Dimensions

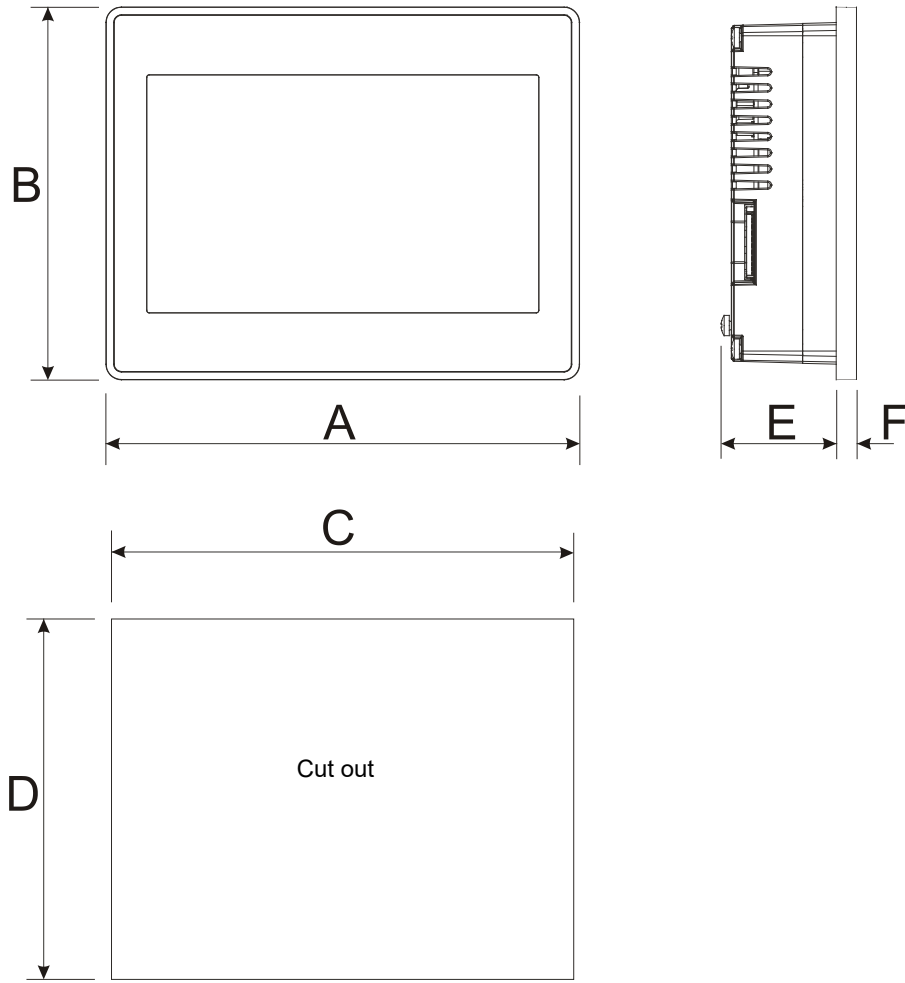

MODEL	A	B	C	D	E	F
<b>eTOP507G</b>	187mm/7.36"	147mm/5.79"	176mm/6.90"	136mm/5.35"	47mm/1.85"	8mm/0.31"
<b>eTOP507MG</b>	187mm/7.36"	147mm/5.79"	176mm/6.90"	136mm/5.35"	47mm/1.85"	8mm/0.31"

# 4 Technical Data

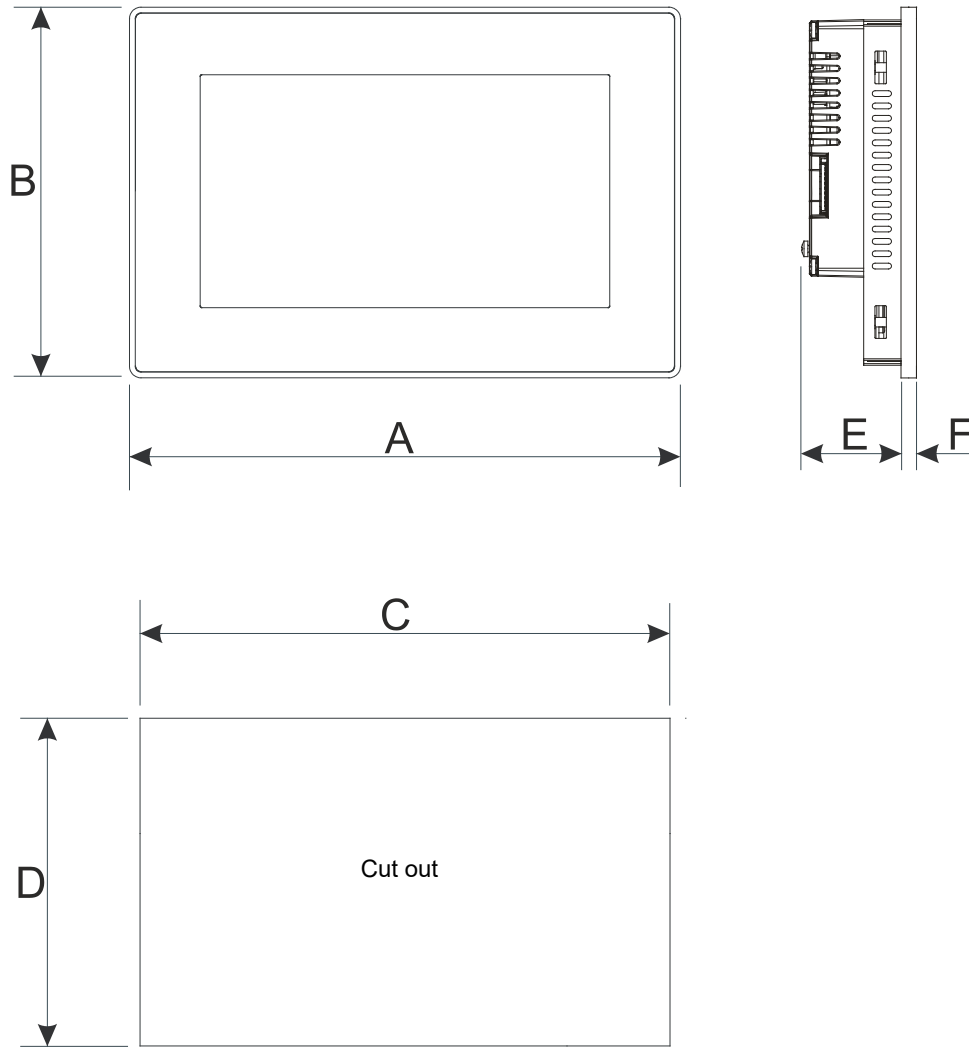

MODEL	A	B	C	D	E	F
<b>eTOP510G</b>	282mm/11.10"	197mm/7.80"	271mm/10.67"	186mm/7.32"	56mm/2.20"	8mm/0.31"

# 4 Technical Data

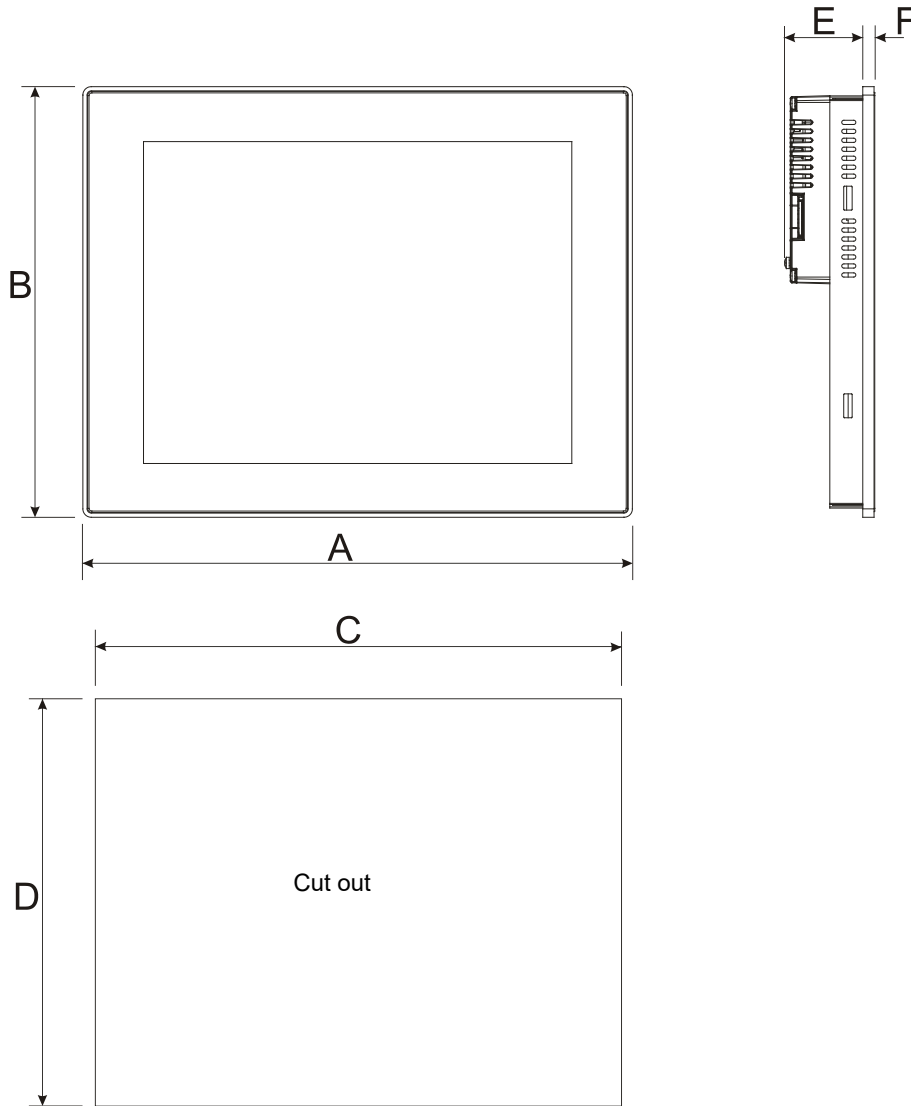

MODEL	A	B	C	D	E	F
<b>eTOP515G</b>	392mm/15.43"	307mm/12.08"	381mm/15"	296mm/11.65"	56mm/2.20"	8mm/0.31"

## 4.2 Installation Environment

Avoid prolonged exposition to direct sunlight to avoid the risk of overheating the device.

The equipment is not intended for installation in contact with corrosive chemical compounds. Check the resistance of the front panel to a specific compound before installation.

Do not use tools of any kind (screwdrivers, etc.) to operate the touch screen of the panel.

In order to meet the front panel protection classifications, proper installation procedure must be followed:

- the borders of the cutout must be flat
- screw up each fixing screw until the bezel corner get in contact with the panel.
- the cutout for the panel must be of the dimensions indicated in this manual.

The IP69 is guaranteed only if:

- max deviation from the plane surface to the cut-out:  $\leq 0.5\text{mm}$
- thickness of the case where is mounted the equipment: from 1,5mm to 6mm
- max surface roughness where the gasket is applied:  $\leq 120\text{ um}$

### Applying the gasket

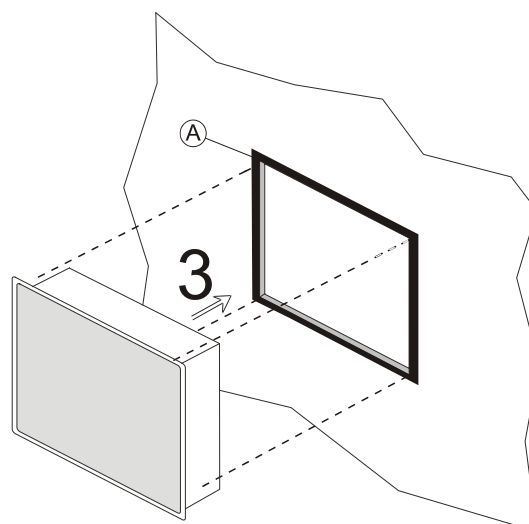
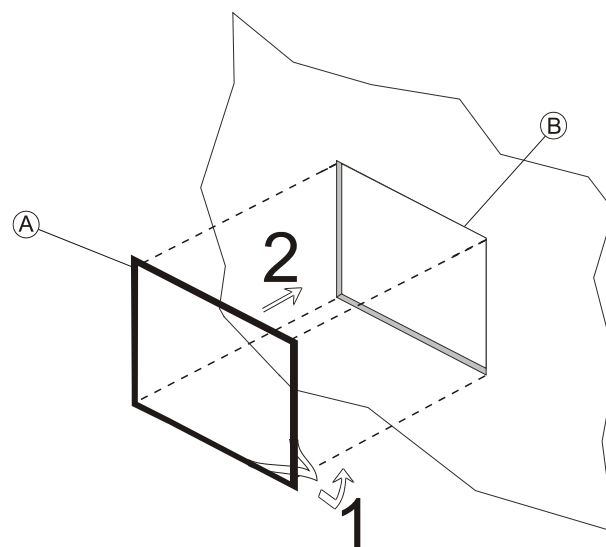

A. Gasket  
B. Installation cut-out



## 4.3 Safety instruction



For all installation notes, please refer to the Installation Guide provided with the product.

## 4.4 Installation Procedure

Place the fixing brackets contained in the fixing kit as shown in figure

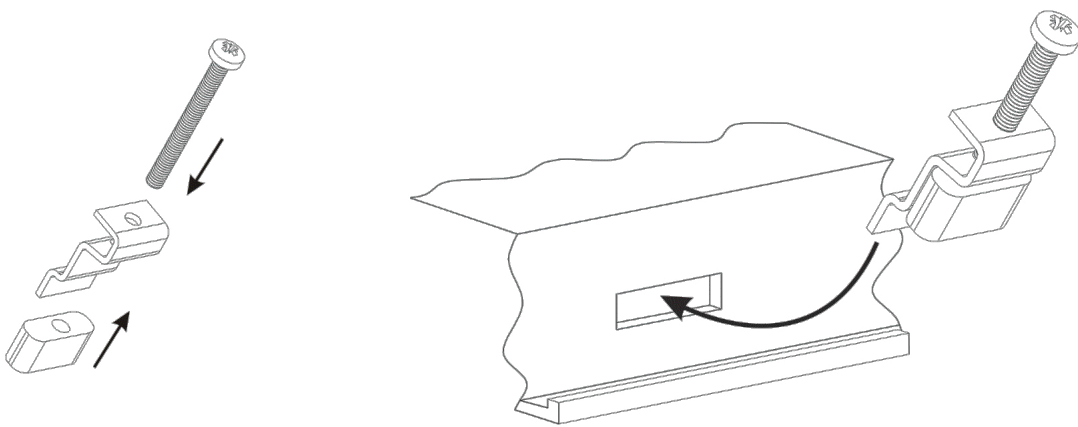

### CAUTION

Tightening torque: 130Ncm or screw each fixing screw until the bezel corner gets in contact with the panel.

# 5 Connections

eTOP507G, eTOP507MG

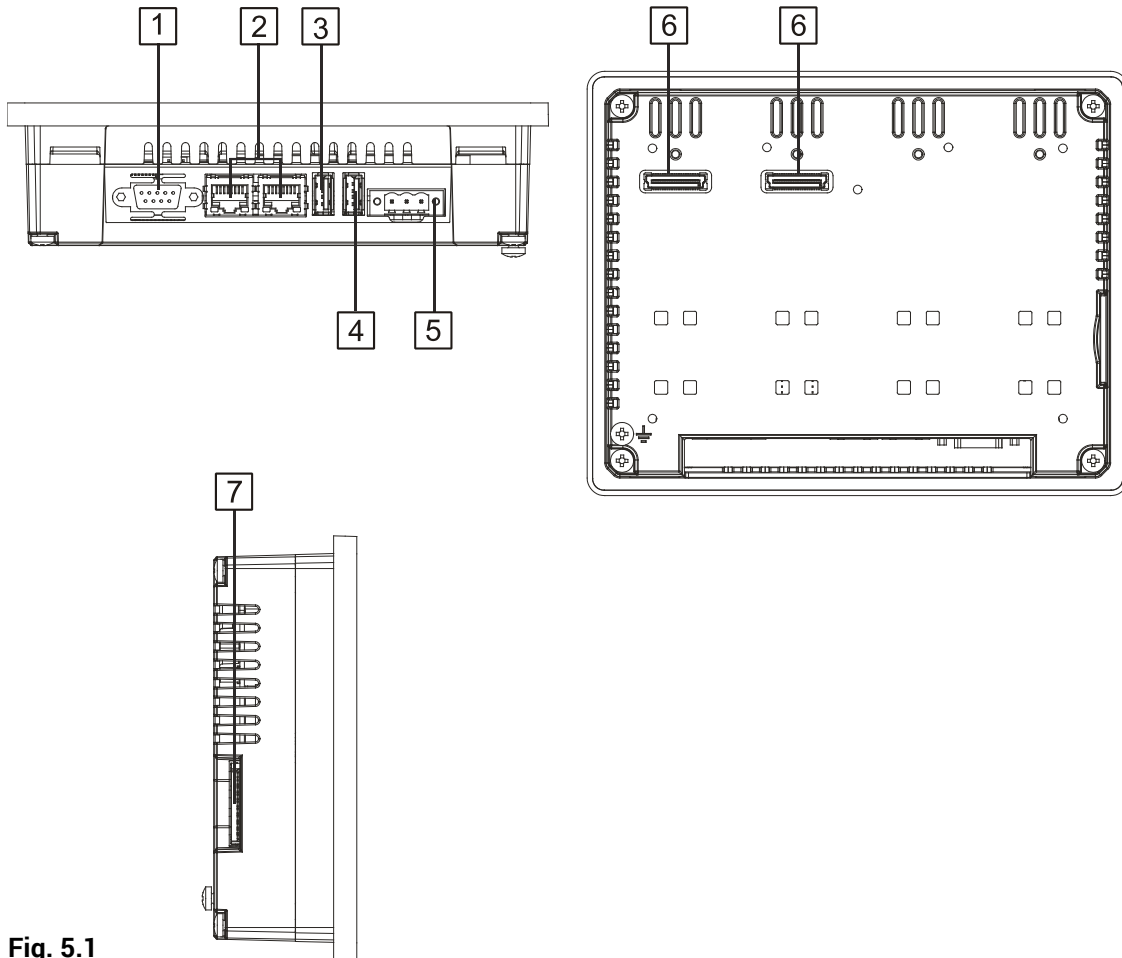
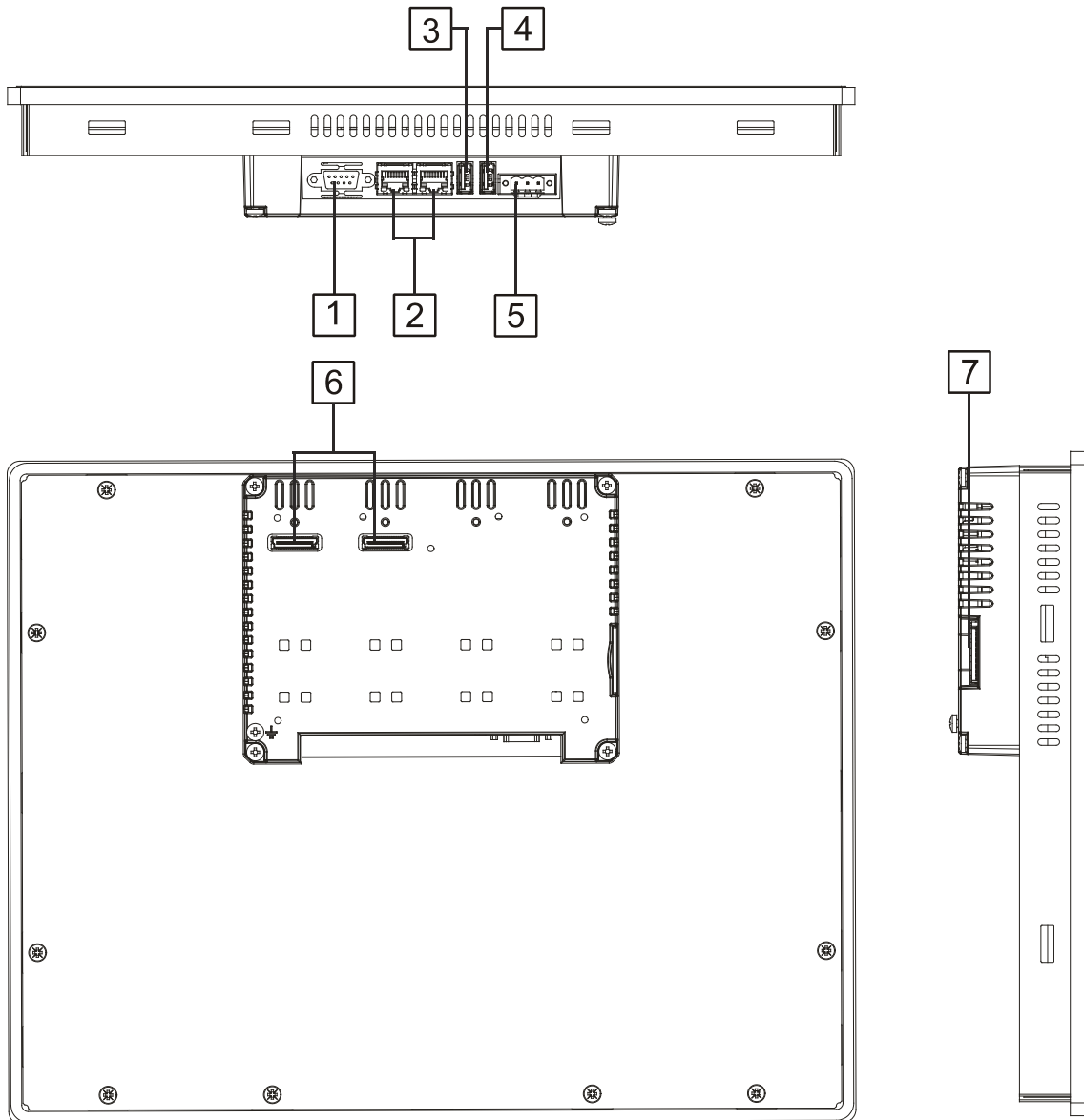

**Fig. 5.1**

- 1. Serial Port
- 2. 2x Ethernet Port
- 3. USB Port (version 2.0 - 1.1)
- 4. USB Port (version 2.0 High speed only)
- 5. Power Supply
- 6. Expansion slot for Plugin module
- 7. SD Card Slot

# 5 Connections

eTOP510G, eTOP515G



**Fig. 5.2**

- 1. Serial Port
- 2. 2x Ethernet Port
- 3. USB Port (version 2.0 - 1.1)
- 4. USB Port (version 2.0 High speed only)
- 5. Power Supply
- 6. 2x Expansion slot for Plugin module
- 7. SD Card Slot

# 5 Connections

## 5.1 Serial Port

The serial port is used to communicate with the PLC or with another type of controller. Different electrical standards are available for the signals in the PLC port connector: RS-232, RS-422, RS-485.

The serial port is software programmable. Make sure you select the appropriate interface in the programming software.

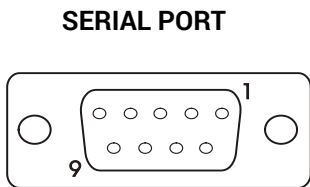

RS-232	
Pin	Description
1	GND
2	
3	TX
4	RX
5	
6	+5V output
7	CTS
8	RTS
9	

RS-422, RS-485	
Pin	Description
1	GND
2	
3	CHA-
4	CHB-
5	
6	+5V output
7	CHB+
8	CHA+
9	

To operate in RS-485 pins 3-4 and 7-8 must be connected externally.

The communication cable must be chosen for the type of device being connected.

## 5.2 Ethernet Port

The Ethernet port have two status indicators. Please see description in figure.

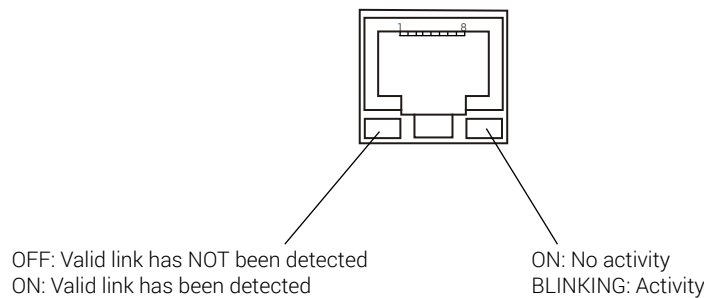

## 5 Connections

### 5.3 Optional plugin module

eTOP500 Glass Serie panels have several optional plugin module, multiple modules configurations are possible.

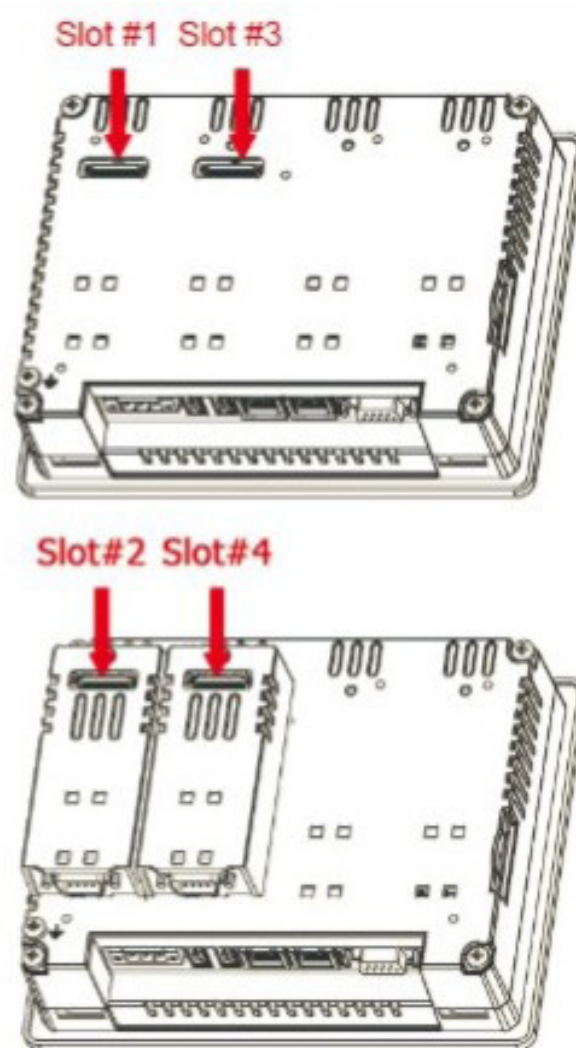

Slot#2 and Slot#4 are available only if plugin module has the “bus extension connector”.

Each slot carries three communication channels:

- 1 serial interface
- 1 CAN interface
- 1 SPI interface

Note: It is not possible to stack two modules that are using the same type of interface.

## 5 Connections

### 5.4 Optional plugin module identification

Note: the PLCM01 label is used as an example for PLCM01, PLCM05, PLIO03

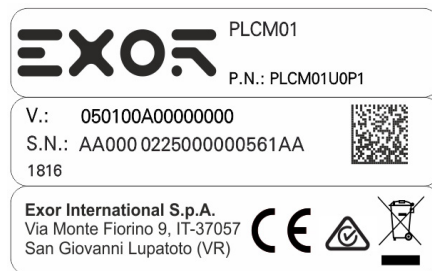

product model name	PLCM01
product part number	PLCM01U0P1
year/week of production	1816
serial number	AA0000225000000561AA
version id of the product	050100A00000000
manufacturer address	Exor International S.p.A. Via Monte Fiorino 9 IT-37057 San Giovanni Lupatoto (VR)

# 5 Connections

## 5.5 Optional plugin module installation procedure

PLCM

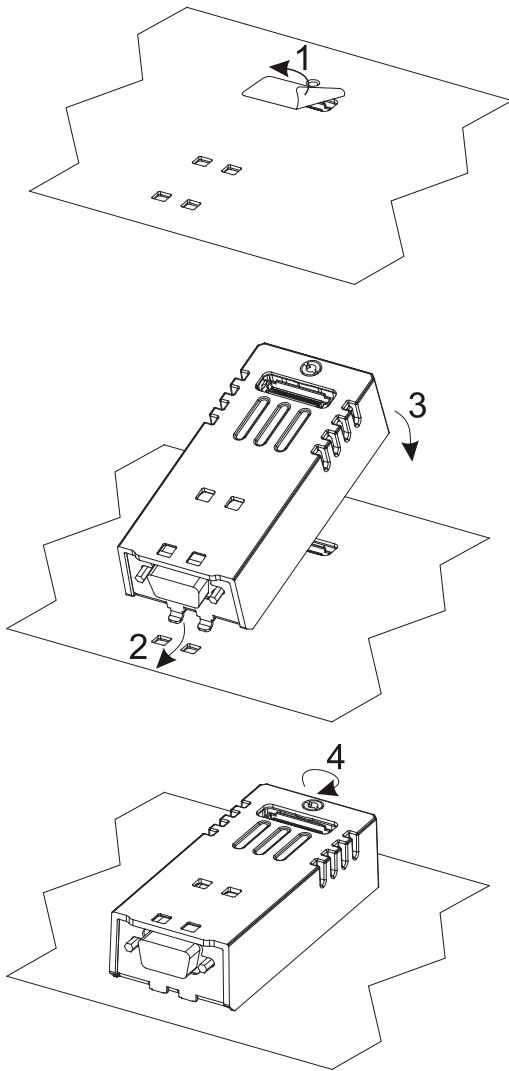

PLI003

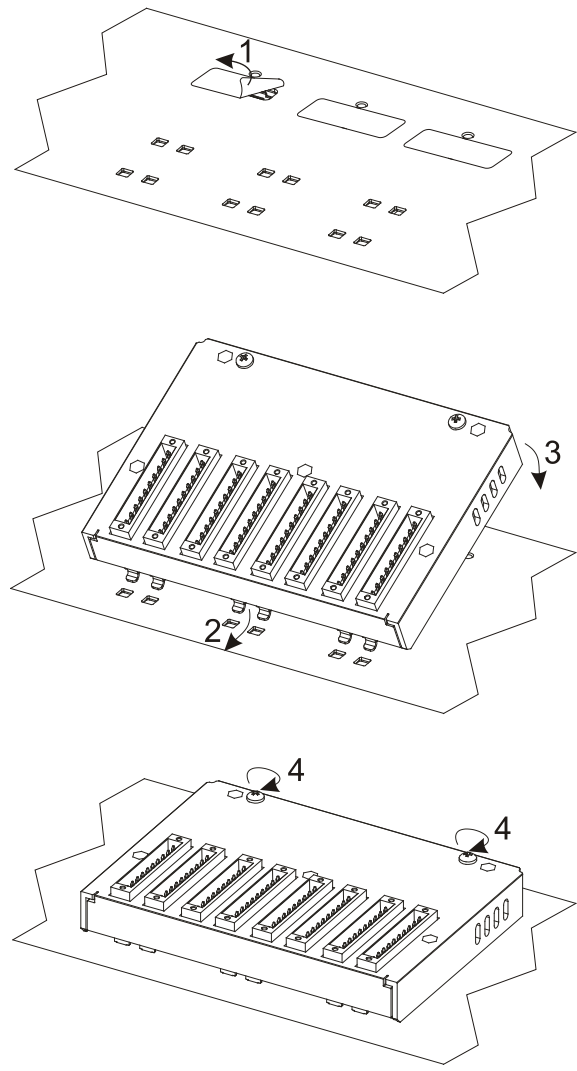

## 5 Connections

Below you can find relation between modules ATEX and IECEx certified and max number of modules that can be used into eTOP500 Glass serie panels, based on their Interface Type:

Module	Application	Max Modules	Interface Type	Bus Extension connector
PLCM01	CAN	2	CAN	Y
PLCM01-NE	CAN	2	CAN	N
PLCM05	CODESYS License	1		Y
PLIO03	Multifunction I/O	1	SPI	N

PLCM01 / PLCM01-NE: Operating temperature -20°C to 60°C  
 PLCM05: Operating temperature -20°C to 60°C  
 PLIO03: Operating temperature 0°C to 50°C (vertical installation), 12-30VDC

PLCM and PLIO03 electrical ratings:

- PLCM01: For electrical rating refers to the host eTOP500 Glass models.
- PLCM05: For electrical rating refers to the host eTOP500 Glass models and PLIO03 ratings
- PLIO03: 20xDigital Inputs voltage 12÷30 Vdc; 12xDigital Outputs voltage 12÷30 Vdc, 0.5A; 4xAnalog inputs 0÷10 Vdc, 4-20mA; 4xAnalog outputs: 0÷10 Vdc, 4-20mA

Below you can find relation between modules and max number of modules that can be used into eTOP500 Glass series panels, based on their Interface Type:

Module	Application	Max Modules	Interface Type	Bus Extension connector
PLCM02	KNX	1	Serial	N
PLCM03	Serial RS232	2	Serial	Y
PLCM04	Serial RS485	2	Serial	Y
PLCM06	Profibus DP	1	SPI	N
PLCM07	Ethernet	1	Ethernet	N
PLIO06	Compact I/O	2	SPI	N

Max modules refers to max number of modules can be plugged into the eTOP500 Glass (all slots),

If you are planning to use PLCM03 and PLCM04 (additional serial ports) you will obtain following "COM - Slot#" association:

- a module plugged in Slot#1 or into Slot#2 will be COM2,
- a module plugged in Slot#3 or into Slot#4 will be COM3.

If you are planning to use two PLCM01 (CAN interface) you will obtain following Slot# association:

- a module plugged in Slot#1 or into Slot#2 will be the CanPort 0,
- a module plugged in Slot#3 or into Slot#4 will be the CanPort 1.



# 6 Power Supply, Grounding and Shielding

The power supply terminal block is shown in the figure below.

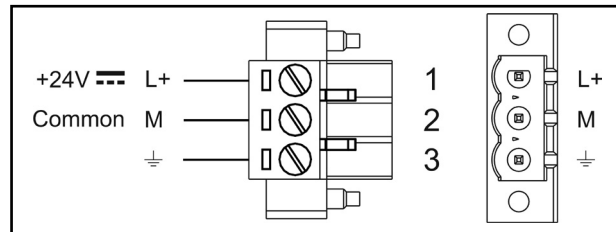

Fig. 6.1

3 conductor 1,5mmq wire size minimum, minimum temperature conductor rating 105°C.

**Note:** Ensure that the power supply has enough power capacity for the operation of the equipment.

The unit must always be grounded to earth with 1,5mmq wire size minimum. Grounding helps limit the effects of noise due to electromagnetic interference on the control system.

Earth connection will have to be done using either the screw or the faston terminal located near the power supply terminal block. A label helps identify the ground connection. Also connect to ground the terminal 3 on the power supply terminal block.

The power supply circuit may be floating or grounded. In the latter case, connect to ground the power source common as shown in figure (see below) with a dashed line.

When using the floating power scheme, note that the panes internally connects the power common to ground with a 1MΩ resistor in parallel with a 4,7nF capacitor.

The power supply must have double or reinforced insulation.

The suggested wiring for the power supply is shown below.

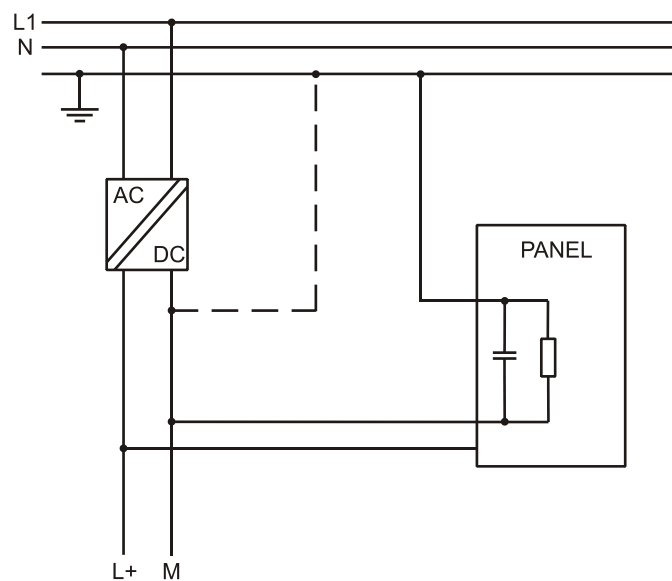

Fig. 6.2

All the electronic devices in the control system must be properly grounded. Grounding must be performed according to applicable regulations.

## 7 Battery

These devices are equipped with rechargeable Lithium battery, not user-replaceable.  
The following information is maintained by the battery:

- hardware real-time clock (date and time)

Charge:

At first installation must be charged for 48 hours.

When the battery is fully charged, it ensures a period of 3 months of data back-up at 25°C.

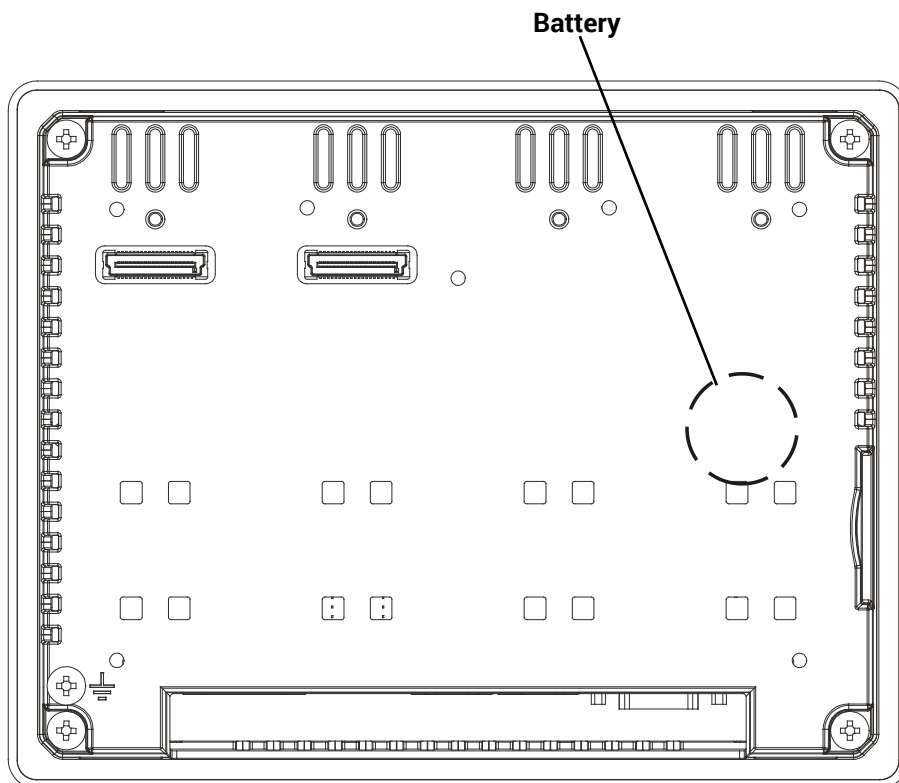
**ATTENTION**

Dispose of batteries according to local regulations.

**ATTENTION**

This device cannot be disposed of as a domestic waste but according to WEEE European Directive 2012/19/EU



## 8 Special Instruction for Use

- The equipment shall only be used in an area of not more than pollution degree 2, as defined in IEC/EN 60664-1.
- The equipment shall be installed in an enclosure that provides a degree of protection not less than IP 54 in accordance with IEC/EN 60079-15.
  - Transient protection shall be provided that is set at a level not exceeding 140 % of the peak rated voltage value at the supply terminals to the equipment.
  - Install the HMI device according to the accompanying installation instructions.
  - Ground the HMI device according to the accompanying installation instructions.
  - Only qualified personnel may install the HMI device or repair it.
  - Ensure that the aeration holes are not covered.
  - Care shall be taken not to allow layers of dust to form on the graphic panel in a way that might cause the accumulation of static charges. Keep the faceplate of the HMI device clean: the equipment must be cleaned only with a soft cloth and neutral soap product. Do not use solvents.
  - This device should not be used for purposes and methods other than indicated in this document and in the documentation accompanying the product.

## 9 Getting Started

eTOP Series 500 Glass HMI products must be programmed with the software JMobile Studio. JMobile Studio is a software tool that must be properly installed on a computer running Microsoft Windows.

There are two options to transfer a JMobile application project to a HMI device:

- |           |  |
|-----------|--|
| Ethernet  | Connect the HMI device to the computer with an Ethernet network connection. From JMobile Studio choose the command Run/Download to target. You may have to ensure that the proper firewall policy has been configured in the computer to allow JMobile Studio to access the network. |
| USB or SD | Create an Update Package using JMobile Studio and copy it to a USB Flash drive or to an SD memory card.  |

# 10 System Settings

eTOP Series 500 Glass HMI products include a System Settings tool to allow configuration of system options.

The user interface of System Settings tool is based on a rotating menu. Use navigation buttons Next/Back to scroll through the available options.

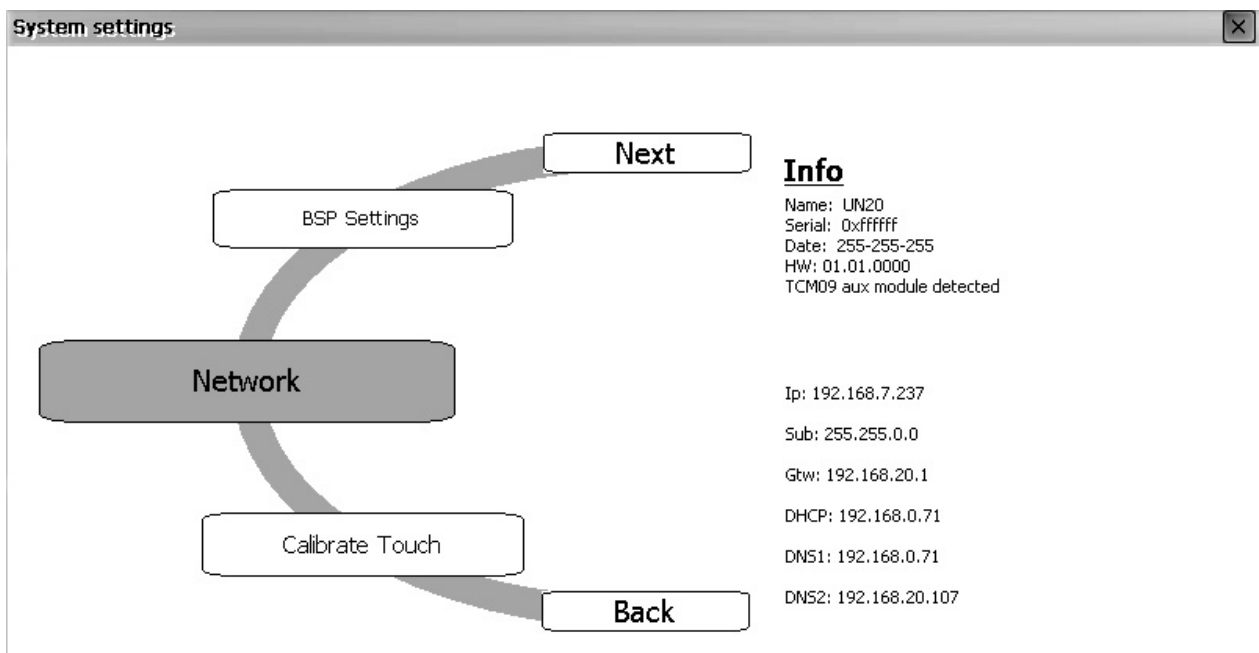

The active item is highlighted on the left side. The info pane on the right side shows relevant information, when applicable. Touch the active item to start the associated function.

System Settings has two modes of operation:

- User Mode** JMobile runtime is running or the HMI device is in "factory default" status.
- System Mode** JMobile runtime is not running or the HMI device has a software failure. System Mode includes all options available in User Mode and offers in additions commands dedicated to system upgrade and recovery.

Activation of System Settings in **User Mode**:

- |   |  |
|---|--|
| <ul style="list-style-type: none"> <li>Factory default status</li> <li>JMobile runtime running</li> </ul> | <ul style="list-style-type: none"> <li>Press "System Setting" button on the HMI screen</li> <li>Recall context menu and select "System Settings". To recall the context menu click and hold any unused area of the touchscreen for a few seconds. Default hold time is 2 seconds.</li> </ul> |
|---|--|

# 10 System Settings

Activation of Systems Settings in **System Mode**:

Normal operation	<p>If JMobile runtime is not running: Press "System Settings" button on the HMI screen.</p> <p>If JMobile runtime is running: recall context menu, select "System Settings"</p> <p>Select the Restart option then choose the "Configuration OS" option.</p> <p><b>Note:</b> To recall the context menu click and hold any unused area of the touchscreen for a few seconds. Default hold time is 2 seconds.</p>
Recovery operation	<p>Use of an SD memory card prepared with a specific file is required. Create and copy the file "\$0030D8\$.bin" to the SD card. Insert the card in the SD slot in the HMI. Apply power to the HMI. When the file is detected, the HMI will show a visual feedback: "Tap Tap detected, Going to Config Mode" on the screen</p> <p><b>Note:</b> "\$0030D8\$.bin" is an empty txt file with specific filename. You can easily create the file by renaming an empty .txt file.</p>

**User Mode** includes options for basic settings of the device.

<b>Calibrate Touch</b>	calibrate the touchscreen interface
<b>Plugin list</b>	show if optional plug-in modules are installed
<b>Network</b>	configure IP Address of Ethernet interface
<b>BSP settings</b>	show the BSP (Board Support Package) version, check the operating hours for the device and for the display backlight, manage the buzzer
<b>Time</b>	change the device date and time, including time zone, Daylight Saving Time and NTP Server
<b>Regional Settings</b>	customize Windows Regional Settings, such as date format
<b>Display</b>	settingsconfigure automatic backlight turnoff and adjust brightness
<b>Close</b>	close System Settings
<b>Restart</b>	restart the device. "Main OS" option restarts as per default, "Configuration OS" option restart device directly into System Settings in System Mode

**System Mode** is the complete interface of the System Settings tool where all functions are available, in addition to the options available in "User Mode".

<b>Format Flash</b>	format internal device Flash disk. All projects, the Runtime and System settings will be deleted, returning the device to factory condition.
<b>Restore Factory Settings</b>	<p>restore factory settings with choice of what to delete. Can be used as alternative to Format Flash. Options available are:</p> <p><a href="#">Uninstall HMI</a> removes the Runtime and all projects.</p> <p><a href="#">Clear system settings</a> reset the system parameters like IP Address, date/time, etc</p> <p><a href="#">Clear Controller Application</a> remove CODESYS application</p>

<b>Resize Image Area</b>	reserved to authorized technical personnel
<b>Download Configuration OS</b>	update the Configuration OS module of BSP
<b>Download Main OS</b>	update the Main OS module of BSP
<b>Download Splash Image</b>	replace the splash screen image displayed by the device at power-up; the image must be supplied in the appropriate binary format. We recommend changing the splash screen image with the use of JMobile Studio
<b>Download OS Partition</b>	reserved to authorized technical personnel
<b>Download Data Partition</b>	reserved to authorized technical personnel
<b>Download Disk Image</b>	reserved to authorized technical personnel
<b>Download Bootloader</b>	update the Bootloader module of BSP
<b>Upload Bootloader</b>	reserved to authorized technical personnel
<b>Upload Configuration OS</b>	reserved to authorized technical personnel
<b>Upload Main OS</b>	reserved to authorized technical personnel
<b>Upload Splash Image</b>	copy to an USB Memory or SD Card the current splash screen image in binary format
<b>Upload OS Partition</b>	reserved to authorized technical personnel
<b>Upload Data Partition</b>	reserved to authorized technical personnel
<b>Upload Disk-Image</b>	copy to an USB Memory or SD Card the content of whole Flash disk in binary format

Only for eTOP607M and eTOP610, System Mode includes also:

<b>Download Main FPGA</b>	update the Main FPGA module of BSP
<b>Download Safe FPGA</b>	update the Safe FPGA module of BSP
<b>Download System Supervisor</b>	update the System Supervisor module of BSP
<b>Upload Main FPGA</b>	reserved to authorized technical personnel
<b>Upload Safe FPGA</b>	reserved to authorized technical personnel
<b>Upload System Supervisor</b>	reserved to authorized technical personnel

# 11 Unpacking and Packing Instructions

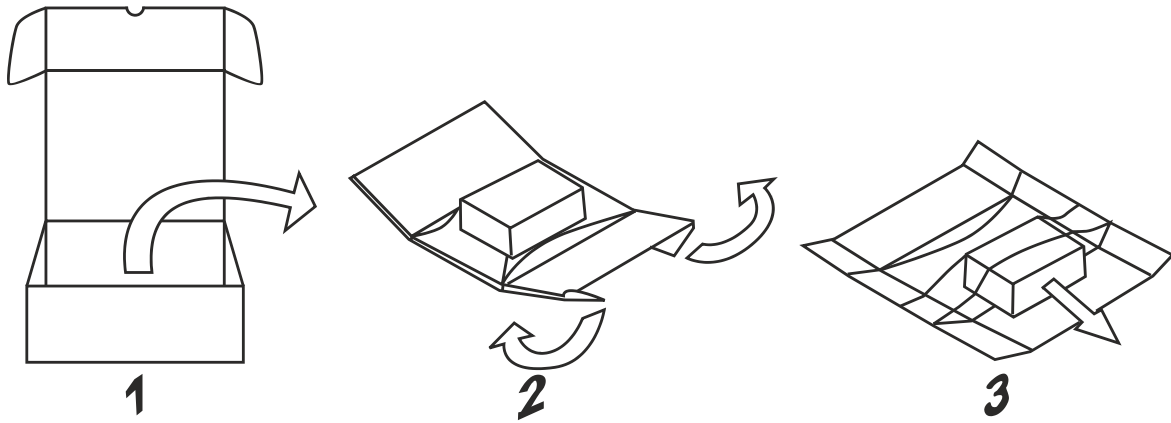

To repack the unit, please follow the instructions backwards.