

WL200 Series Inverter Basic Manual

- Single-phase Input 200V class
- Three-phase Input 400V class

Manual Number: NT3531X
Sep. 2015

Refer to the user manual for detail

Hitachi Industrial Equipment Systems Co., Ltd.

Introduction

Thank you for purchasing the Hitachi WL200 series inverter.

Please read this Basic Manual and Instruction manual, and understand perfectly how to handle properly and the safety cautions of the product before operation, for safety and proper usage.

Note that this Basic Manual is intended for each product and should be delivered to the end user of the inverter.

Safety precautions

Be sure to read this Basic Manual and appended documents thoroughly before installing, operating the inverter.

Maintenance and service items in this Basic Manual are only caution related items. Read the Instruction manual carefully before starting the maintenance and service. (Instruction manual can be downloaded from our website.)

In the Instruction Manual, safety instructions are classified into two levels, namely WARNING and CAUTION.

 : Indicates that incorrect handling may cause hazardous situations, which may result in serious personal injury or death.

 : Indicates that incorrect handling may cause hazardous situations, which may result in moderate or slight personal injury or physical damage alone.

Note that even a  level situation may lead to a serious consequence according to circumstances. Be sure to follow every safety instruction, which contains important safety information. Also focus on and observe the items and instructions described under "Notes" in the text.

CAUTION

Many of the drawings in the Instruction Manual show the inverter with covers and/or parts blocking your view being removed.
Do not operate the inverter in the status shown in those drawings. If you have removed the covers and/or parts, be sure to reinstall them in their original positions before starting operation, and follow all instructions in the Instruction Manual when operating the inverter.

1. Installation

CAUTION

- Install the inverter on a non-flammable surface, e.g., metal. Otherwise, you run the risk of fire.
- Do not place flammable materials near the installed inverter. Otherwise, you run the risk of fire.
- When carrying the inverter, do not hold its top cover. Otherwise, you run the risk of injury and damage by dropping the inverter.
- Prevent foreign matter (e.g., cut pieces of wire, sputtering welding materials, iron chips, wire, and dust) from entering the inverter. Otherwise, you run the risk of fire.
- Install the inverter on a structure able to bear the weight specified in this document. Otherwise, you run the risk of injury due to the inverter falling.
- Install the inverter on a vertical wall that is free of vibrations. Otherwise, you run the risk of injury due to the inverter falling.
- Do not install and operate the inverter if it is damaged or its parts are missing. Otherwise, you run the risk of injury.
- Install the inverter in a well-ventilated indoor site not exposed to direct sunlight. Avoid places where the inverter is exposed to high temperature, high humidity, condensation, dust, explosive gases, corrosive gases, flammable gases, grinding fluid mist, or salt water. Otherwise, you run the risk of fire.
- The inverter is precision equipment. Do not allow it to fall or be subject to high impacts, step on it, or place a heavy load on it. Doing so may cause the inverter to fail.

2. Wiring

WARNING

Be sure to ground the inverter. Otherwise, you run the risk of electric shock or fire.

- Commit wiring work to a qualified electrician. Otherwise, you run the risk of electric shock or fire.
- Before wiring, make sure that the power supply is off. Otherwise, you run the risk of electric shock or fire.
- Perform wiring only after installing the inverter. Otherwise, you run the risk of electric shock or injury.
- The inverter must be powered OFF before you change any of the slide switch settings. Otherwise, you run the risk of electric shock or injury.

CAUTION

Make sure that the voltage of AC power supply matches the rated voltage of your inverter. Otherwise, you run the risk of injury or fire.

- Do not input single-phase power into the 3-phase inverter. Otherwise, you run the risk of fire.
- Do not connect AC power supply to any of the output terminals (U, V, and W). Otherwise, you run the risk of injury or fire.
- Connect an earth-leakage breaker to the power input circuit. Otherwise, you run the risk of fire.
- Use only the power cables, earth-leakage breaker, and magnetic contactors that have the specified capacity (ratings). Otherwise, you run the risk of fire.
- Do not use the magnetic contactor installed on the primary and secondary sides of the inverter to stop its operation.
- Tighten each screw to the specified torque. No screws must be left loose. Otherwise, you run the risk of fire
- Before operating slide switch in the inverter, be sure to turn off the power supply. Otherwise, you run the risk of electric shock and injury.
- Please make sure that earth or ground screw is tightened properly and completely.
- First, check the screws of output terminal (U, V and W) are properly tightened, and then tighten the screws of input terminal (R, S and T)

3. Operation

WARNING

- While power is supplied to the inverter, even if the inverter has stopped, do not touch any terminal or internal part of the inverter, insert a bar in it, check signals, or connect or disconnect any wire or connector. Otherwise, you run the risk of electric shock, injury or fire.
- Be sure to close the terminal block cover before turning on the inverter power. Do not open the terminal block cover while power is being supplied to the inverter or voltage remains inside. Otherwise, you run the risk of electric shock.
- Do not operate switches with wet hands. Otherwise, you run the risk of electric shock.
- If the retry mode has been selected, the inverter will restart suddenly after a break in the tripping status. Stay away from the machine controlled by the inverter when the inverter is under such circumstances. (Design the machine so that human safety can be ensured, even when the inverter restarts suddenly.) Otherwise, you run the risk of injury.
- Do not select the retry mode for controlling an elevating or traveling device because output free-running status occurs in retry mode. Otherwise, you run the risk of injury or damage to the machine controlled by the inverter.
- If an operation command has been input to the inverter before a short-term power failure, the inverter may restart operation after the power recovery. If such a restart may put persons in danger, design a control circuit that disables the inverter from restarting after power recovery. Otherwise, you run the risk of injury.
- Prepare the additional emergency stop switch in addition to the stop key of the integrated operator and/or the optional operator. Otherwise, there is a danger of injury.
- If an operation command has been input to the inverter before the inverter enters alarm status, the inverter will restart suddenly when the alarm status is reset. Before resetting the alarm status, make sure that no operation command has been input.

 **CAUTION**

- Do not touch the heat sink, which heats up during the inverter operation. Otherwise, you run the risk of burn injury.
- The inverter allows you to easily control the speed of motor or machine operations. Before operating the inverter, confirm the capacity and ratings of the motor or machine controlled by the inverter. Otherwise, you run the risk of injury.
- Install an external brake system if needed. Otherwise, you run the risk of injury.
- When using the inverter to operate a standard motor at a frequency of over 60 Hz, check the allowable motor speeds with the manufacturers of the motor and the machine to be driven and obtain their consent before starting inverter operation. Otherwise, you run the risk of damage to the motor and machine.
- During inverter operation, check the motor for the direction of rotation, abnormal sound, and vibrations. Otherwise, you run the risk of damage to the machine driven by the motor.
- **HIGH VOLTAGE:** Dangerous voltage exists even after the Safe Stop is activated. It does NOT mean that the main power has been removed.

4. Maintenance, inspection, and parts replacement

 **WARNING**

- Before inspecting the inverter, be sure to turn off the power supply and wait for 10 minutes or more. Otherwise, you run the risk of electric shock. (Before inspection, confirm that the Charge lamp on the inverter is off.)
- Commit only a designated person to maintenance, inspection, and the replacement of parts. (Be sure to remove wristwatches and metal accessories, e.g., bracelets, before maintenance and inspection work and to use insulated tools for the work.) Otherwise, you run the risk of electric shock and injury.
- Do not rely upon the STO feature to disconnect the power from the motor circuit. It is required isolate the supply before any maintenance is carried out on the motor circuit. See Functional Safety for detail.

5. Others

 **WARNING**

- Never modify the inverter. Otherwise, you run the risk of electric shock and injury.

 **CAUTION**

- Do not discard the inverter with household waste. Contact an industrial waste management company in your area who can treat industrial waste without polluting the environment.

6. When using Safe Stop Function (Certification in progress)

 **WARNING**

- When using Safe Stop function, make sure to check whether the safe stop function properly works when installation (before starting operation). Please carefully refer to Functional Safety for detail.

Contact an industrial waste management company in your area who can treat industrial waste without polluting the environment.

UL® Cautions, Warnings and Instructions

Warnings and Cautions for Troubleshooting and Maintenance

(Standard to comply with : UL508C,CSA C22.2 No.14-05)

Warning Markings

GENERAL:

These devices are open type Power Conversion Equipment. They are intended to be used in an enclosure. Insulated gate bipolar transistor (IGBT) incorporating microprocessor technology. They are operated from a single or three-phase source of supply, and intended to control three-phase induction motors by means of a variable frequency output. The units are intended for general-purpose industrial applications.

MARKING REQUIREMENTS:

Ratings - Industrial control equipment shall be plainly marked with the Listee's name, trademark, File number, or other descriptive marking by which the organization responsible for the product may be identified;

- a) "Maximum surrounding air temperature rating of 50 °C."
- b) "Solid State motor overload protection reacts with max. 150 % of FLA".
- c) "Install device in pollution degree 2 environment."
- d) "Suitable for use on a circuit capable of delivering not more than 100,000 rms Symmetrical Amperes, 240 or 480 Volts Maximum."

- e) "When Protected by CC, G, J or R Class fuses." or "When Protected By A Circuit Breaker Having An Interrupting Rating Not Less Than 100,000 rms Symmetrical Amperes, 240 or 480 Volts Maximum."

- f) "Integral solid state short circuit protection does not provide branch circuit protection. Branch circuit protection must be provided in accordance with the National Electrical Code and any additional local codes."

- g) "Motor over temperature protection is not provided by the drive.."

Terminal symbols and Screw size

“Use 60/75°C Cu wire only” or equivalent.

For models WL200-022S, -004H, -007H, -015H, -022H, -030H, and -040H.

“Use 75°C Cu wire only” or equivalent.

For models WL200-002S, -004S, -007S, -015S, -055H, -075H -110H, -150H and -185H.

Inverter Model	Screw Size	Required Torque (N-m)	Wire range
WL200-002S WL200-004S WL200-007S	M3.5	1.0	AWG16 (1.3mm ²)
WL200-015S	M4	1.4	AWG12 (3.3mm ²)
WL200-022S	M4	1.4	AWG10 (5.3mm ²)
WL200-004H WL200-007H WL200-015H WL200-022H	M4	1.4	AWG16 (1.3mm ²)
WL200-030H	M4	1.4	AWG14 (2.1mm ²)
WL200-040H WL200-055H	M4	1.4	AWG12 (3.3mm ²)
WL200-075H WL200-110H	M5	3.0	AWG10 (5.3mm ²)
WL200-150H WL200-185H	M6	3.9 to 5.1	AWG6 (13mm ²)

(For more details, please refer to page12.)

Fuse Sizes

Distribution fuse size marking is included in the manual to indicate that the unit shall be connected with a Listed Cartridge Nonrenewable fuse, rated 600 Vac with the current ratings as shown in the table below or Type E Combination Motor Controller marking is included in the manual to indicate that the unit shall be connected with, LS Industrial System Co.,Ltd,Type E Combination Motor Controller MMS Series with the ratings as shown in the table below:

Inverter Model	Fuse		Inverse Time Circuit Breaker	Type E CMC
	Type	Rating (Maximum A)	Rating (Maximum A)	
WL200-002S WL200-004S WL200-007S	Class J, Class CC, Class G, Class T	10A, AIC 200kA	30A	MMS-32H, 240V,40A
WL200-015S		20A, AIC 200kA		
WL200-022S		30A, AIC 200kA		
WL200-004H WL200-007H WL200-015H WL200-022H		10A, AIC 200kA	20A	MMS-32H, 480V,40A or MMS-63H, 480V,52A
WL200-030H WL200-040H WL200-055H		15A, AIC 200kA		
WL200-075H		30A, AIC 200kA	40A	
WL200-110H WL200-150H WL200-185H		50A, AIC 200kA		

Inverter Specification Label

The Hitachi WL200 inverters have product labels located on the right side of the housing, as pictured below. Be sure to verify that the specifications on the labels match your power source, and application safety requirements.

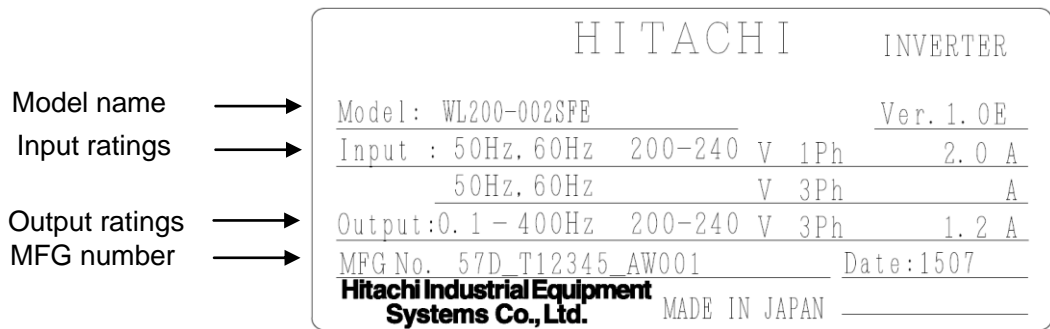

Inverter Model Name

The model number for a specific inverter contains useful information about its operating characteristics. Refer to the model number legend below:

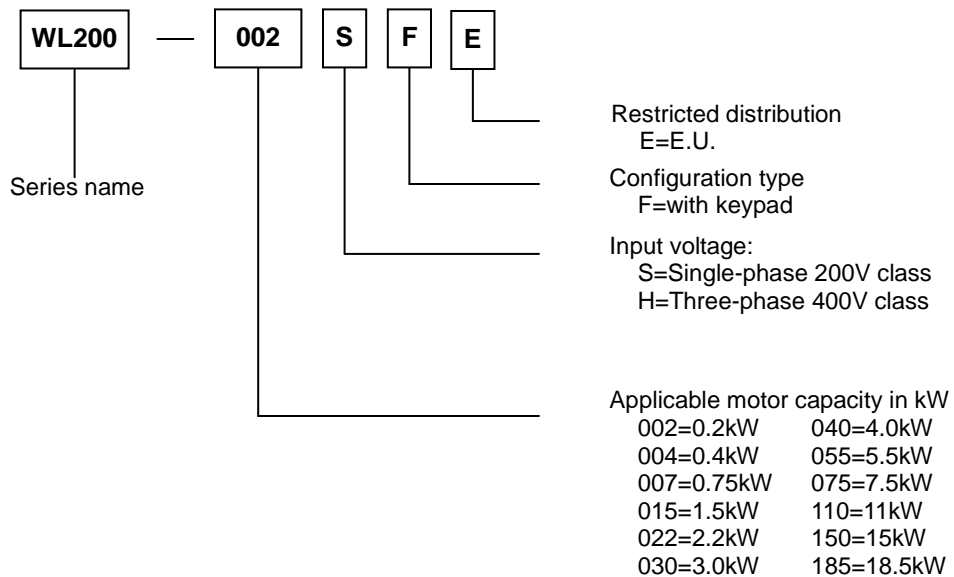

WL200 Inverter Specifications

Model-specific tables for 200V and 400V class inverters

The following tables are specific to WL200 inverters for the 200V and 400V class model groups.

Item		Single-phase 200V class Specifications				
WL200 inverters, 200V models		002SFE	004SFE	007SFE	015SFE	022SFE
Applicable motor size	kW	0.2	0.4	0.75	1.5	2.2
	HP	1/4	1/2	1	2	3
Rated capacity (kVA)	200V	0.4	1.2	1.5	2.8	4.1
	240V	0.5	1.4	1.8	3.4	4.9
Rated input voltage		Single-phase: 200V-15% to 240V +10%, 50/60Hz \pm 5%				
Rated output voltage		Three-phase: 200 to 240V (proportional to input voltage)				
Rated output current (A)		1.2	2.6	3.5	6.0	9.6
Braking	Without resistor	100%: \leq 50Hz, 50%: \leq 60Hz				70%: \leq 50Hz, 50%: \leq 60Hz
	With resistor	150%				
DC braking		Variable operating frequency, time, and braking force				
Weight	kg	1.0	1.1	1.1	1.6	1.8
	lb	2.2	2.4	2.4	3.1	4.0

Item		Three-phase 400V class Specifications					
WL200 inverters, 400V models		004HFE	007HFE	015HFE	022HFE	030HFE	040HFE
Applicable motor size	kW	0.4	0.75	1.5	2.2	3.0	4.0
	HP	1/2	1	2	3	4	5
Rated capacity (kVA)	380V	1.4	1.4	2.9	3.9	5.4	6.2
	480V	1.7	1.8	3.6	5.0	6.8	7.9
Rated input voltage		Three-phase: 380V-15% to 480V +10%, 50/60Hz \pm 5%					
Rated output voltage		Three-phase: 380 to 480V (proportional to input voltage)					
Rated output current (A)		1.5	2.1	4.1	5.4	6.9	8.8
Braking	Without resistor	100%: \leq 50Hz, 50%: \leq 60Hz			70%: \leq 50Hz, 20%: \leq 60Hz	20%: \leq 50Hz, 20%: \leq 60Hz	
	With resistor	150%			100%		
DC braking		Variable operating frequency, time, and braking force					
Weight	kg	1.5	1.5	1.6	1.8	1.9	1.9
	lb	3.3	3.3	3.5	4.0	4.2	4.2

Item		Three-phase 400V class Specifications					
WL200 inverters, 400V models		055HFE		075HFE	110HFE	150HFE	185HFE
Applicable motor size	kW	5.5		7.5	11	15	18.5
	HP	7.5		10	15	25	25
Rated capacity (kVA)	380V	8.8		13.2	15.8	25.1	29.0
	480V	11.1		16.7	20.0	31.6	36.6
Rated input voltage		Three-phase: 380V-15% to 480V +10%, 50/60Hz \pm 5%					
Rated output voltage		Three -phase: 380 to 480V (proportional to input voltage)					
Rated output current (A)		11.1		17.5	23.0	31.0	38.0
Braking	Without resistor	20%: \leq 50Hz , 20%: \leq 60Hz		20%: \leq 50Hz, 20%: \leq 60Hz			
	With resistor	100%		80%			
DC braking		Variable operating frequency, time, and braking force					
Weight	kg	2.1		3.5	3.5	4.7	5.2
	lb	4.6		7.7	7.7	10.4	11.5

NOTE: In Single-phase 200V class and Three-phase 400V class, Inverter types over 2.2kW have some cooling fan.

WL200 Inverter Specifications, continued...

General Specifications

Item		Specifications
Protection structure Note 4)		Open type (IP20)
Control	Control method	Line-to-line sinusoidal PWM method
	Output frequency range Note 5)	0.10 to 400Hz
	Frequency accuracy Note 6)	For maximum frequency, digital command $\pm 0.01\%$, analog command $\pm 0.2\%$ ($25\pm 10^{\circ}\text{C}$)
	Frequency setting resolution	Digital setting: 0.01Hz Analog setting: Maximum frequency/1000
	Voltage/Frequency characteristic	V/f characteristic (Constant torque, Reduced torque, Free V/f)
	Rated overload current	120%/ 1 minute and 140%/ 12seconds
	Acceleration/Deceleration time	0.00 to 3600 seconds (Linear, Curve optional setting). Second acceleration/deceleration setting available.
	Carrier frequency	2 to 10 kHz
DC braking		Operates when frequency became lower than deceleration frequency by stop command, or when frequency became lower than setting frequency at running, or by external input (level and time setting available).
Protection function		Against overcurrent, overvoltage, undervoltage, electronic thermal, abnormal temperature, earth fault overcurrent when powered on, overload, over receive voltage, external trip, memory error, CPU error, USP error, communication error, overvoltage suppression at deceleration, momentary electric outage, emergency interrupt, etc.
Input signal	Frequency setting	Digital/Remote operator External Analog input signal: Variable resistor/ DC0 to 10V / 4 to 20mA, Modbus communication
	Operation/Stop command	Digital/Remote operator External digital signal (3 wire input available), Modbus communication
	Intelligent input	7 points (1, 2, 3/GS1, 4/GS2, 5/PTC, 6, 7/EB)
	Analog input	2 points (Voltage O terminal: 10bit/0 to 10V, Current OI terminal: 10bit/0 to 20mA)
Output signal	Intelligent output	2 points (11/EDM, 12)
	Intelligent relay output	1 point (1c contact point (AL0, AL1, AL2))
	Analog output	1 point (AM terminal: 10bit/0 to 10V)
	Pulse output	1 point (EO terminal: 32kHz (10V))
Communication	RS-422	RJ45 connector, Operator use
	RS-485	Control circuit terminal stage, Modbus
	USB	USB1.1, mini-B connector
Other functions	AVR function, V/f characteristic switching, Upper/Lower limiter, 16 stage multi speed, Starting frequency adjustment, Jogging operation, Carrier frequency adjustment, PID control, Frequency jump, Analog-in bias adjustment, S-type acceleration.deceleratio, Electronic thermal characteristic/Level adjustment, Retry function, Torque boost function, Trip monitor, Soft lock function, Frequency conversion display, USP function, Second control function, UP/DOWN, Overcurrent suppress function, etc.	
General specifications	Ambient temperature	-10 to 40°C (Derating is required) (Refer to the instruction manual)
	Storage temperature	-20 to 65°C (Short time temperature during transportation)
	Humidity	20 to 90% RH
	Vibration	5.9m/s ² (0.6G), 10 to 55Hz
	Service space	Altitude lower than 1,000m, In-door (No corrosive gas, no dust)
	Painting color	No painting, [Mold: Black(Munsell N1.5)]
Applicable standard		UL, CE, C-UL, C-tick, Safety Note 7)
Options		Noise filter, DC Reactor, AC Reactor, Remote operator, Connector cable, Regenerative break unit, and Resistor, etc.

Note 1) Applicable motor is reference motor. When select motors, take notice so that rated current of motor does not exceed over the inverter's rated current.

Note 2) Output voltage decreases when power supply voltage is decreased.

Note 3) Control torque at capacitor feeding back is an average deceleration torque at the time of shortest deceleration in motor unit (when stopped from 50Hz), not a continuous regenerated torque. Average deceleration torque changes depending on motor loss. When operated exceeding over 50Hz, this value is decreased.

Note 4) Protection method is compliant with JEM1030.

Note 5) When you operate motor exceeding over 50/60Hz, please inquire about an allowable maximum number of rotations of motor, etc. to motor manufacturer.

Note 6) In order to control motors stably, output frequency may exceed over the maximum frequency set by A004 (A204) by max. 2Hz.

Note 7) Functional safety certification is in progress.

Note 8) In the case the current tends to increase, for example to trip with overcurrent when torque boost is activated, please try to operate after initializing with the setting b085=00.

Note 9) Parameter setting and EzSQ program cannot be copied between WL200 and WJ200.

Note 10) Overcurrent trip level may exceed the level of 200% of nominal current depending on models.

NOTE: In Single-phase 200V class and Three-phase 400V class, Inverter types over 2.2kW have some cooling fan.

The following table shows which models need derating.

1-ph 200V class	Need derating	3-ph 400V class	Need derating	3-ph 400V class	Need derating
WL200-002S	—	WL200-004H	—	WL200-040H	✓
WL200-004S	—	WL200-007H	—	WL200-055H	✓
WL200-007S	✓	WL200-015H	✓	WL200-075H	—
WL200-015S	✓	WL200-022H	—	WL200-110H	✓
WL200-022S	—	WL200-030H	—	WL200-150H	✓
				WL200-185H	✓

✓ : need derating — : need no derating

Use the derating curves to help determine the optimal carrier frequency setting for your inverter and find the output current derating. Be sure to use the proper curve for your particular WL200 inverter model number. For detail of the derating curves, please refer to Instruction manual. (Instruction manual can be downloaded from our website.)

Basic System Description

A motor control system will obviously include a motor and inverter, as well as a circuit breaker or fuses for safety. If you are connecting a motor to the inverter on a test bench just to get started, that's all you may need for now. But a system can also have a variety of additional components. Some can be for noise suppression, while others may enhance the inverter's braking performance. The figure and table below show a system with all the **optional** components you might need in your final application.

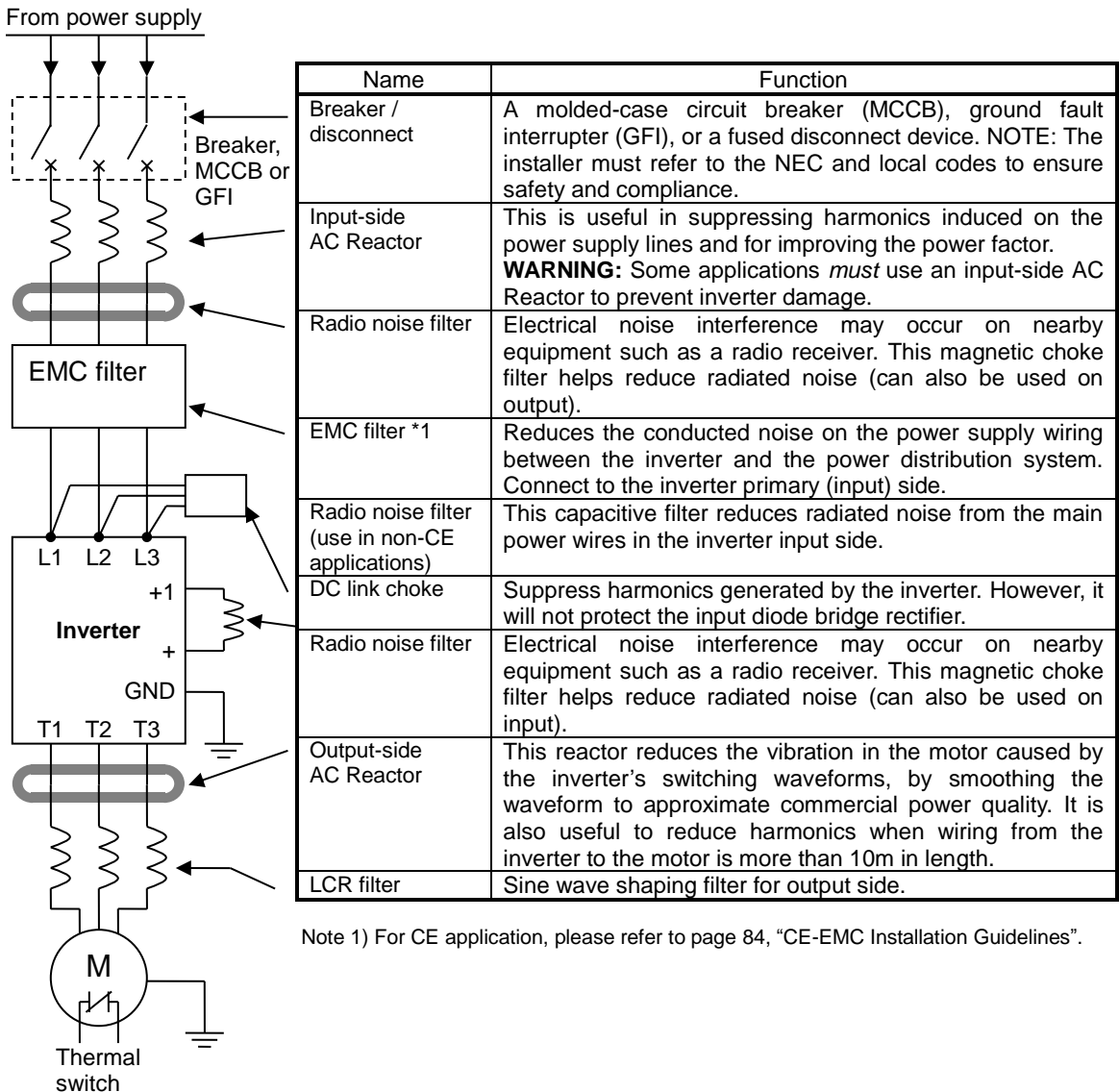

Determining Wire and Fuse Sizes

The maximum motor current in your application determines the recommended wire size. The following table gives the wire size in AWG. The “Power Lines” column applies to the inverter input power, output wires to the motor, the earth ground connection, and any other components shown in the “Basic System Description” on page 11. The “Signal Lines” column applies to any wire connecting to the two green connectors just inside the front cover panel.

Motor Output		Inverter Model	Wiring		Applicable equipment
kW	HP		Power Lines	Signal Lines	Fuse (UL-rated, class J, CC,G,T, 600V , Maximum allowable current)
0.2	1/4	WL200-002SFE	AWG16 / 1.3mm ² (75°C only)	18 to 28 AWG / 0.14 to 0.75 mm ² shielded wire (see Note 4)	10A
0.4	1/2	WL200-004SFE			
0.75	1	WL200-007SFE			
1.5	2	WL200-015SFE	AWG12 / 3.3mm ² (75°C only)		20A
2.2	3	WL200-022SFE	AWG10 / 5.3mm ²		30A
0.4	1/2	WL200-004HFE	AWG16 / 1.3mm ²		10A
0.75	1	WL200-007HFE			
1.5	2	WL200-015HFE			
2.2	3	WL200-022HFE			
3.0	4	WL200-030HFE	AWG14 / 2.1mm ²		15A
4.0	5	WL200-040HFE	AWG12 / 3.3mm ²		
5.5	7.5	WL200-055HFE	AWG10/ 5.3mm ² (75°C only)	30A	
7.5	10	WL200-075HFE			
11	15	WL200-110HFE			
15	20	WL200-150HFE			
18.5	25	WL200-185HFE	AWG6 / 13mm ² (75°C only)	50A	

Note 1: Field wiring must be made by a UL-Listed and CSA-certified closed-loop terminal connector sized for the wire gauge involved. Connector must be fixed by using the crimping tool specified by the connector manufacturer.

Note 2: Be sure to consider the capacity of the circuit breaker to be used.

Note 3: Be sure to use a larger wire gauge if power line length exceeds 66ft. (20m).

Note 4: Use 18 AWG / 0.75mm² wire for the alarm signal wire ([AL0], [AL1], [AL2] terminals).

Wire the Inverter Input to a Supply

In this step, you will connect wiring to the input of the inverter. First, you must determine whether the inverter model you have required three-phase power only, or single-phase power only. All models have the same power connection terminals **[R/L1]**, **[S/L2]**, and **[T/L3]**. **So you must refer to the specifications label (on the side of the inverter) for the acceptable power source types!** For inverters that can accept single-phase power and are connected that way, terminal **[S/L2]** will remain unconnected.

Note the use of ring lug connectors for a secure connection.

Single-phase 200V 0.2 to 0.75kW

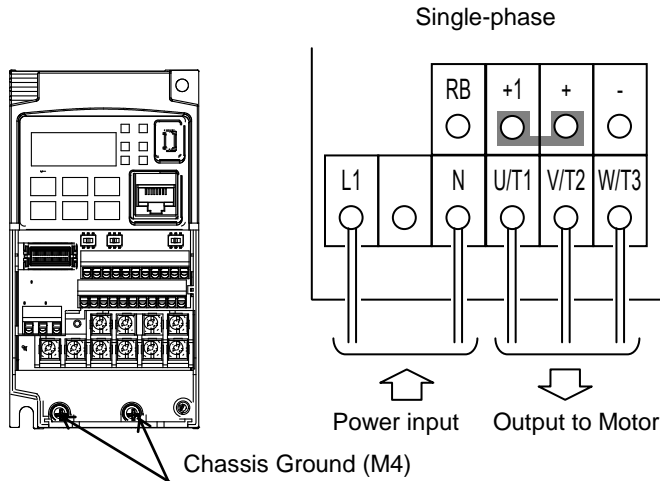

Single-phase 200V 1.5 to 2.2kW Three-phase 400V 0.4 to 4.0kW

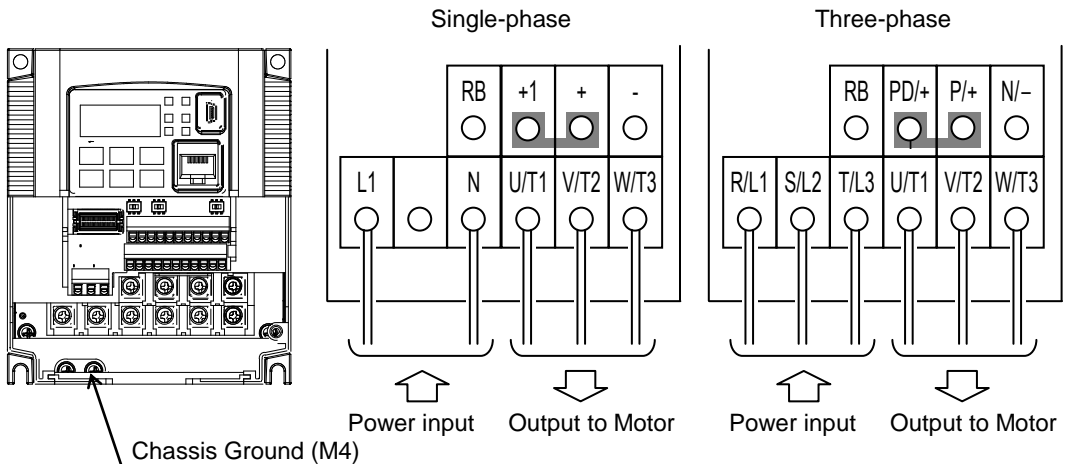

Three-phase 400V 5.5kW

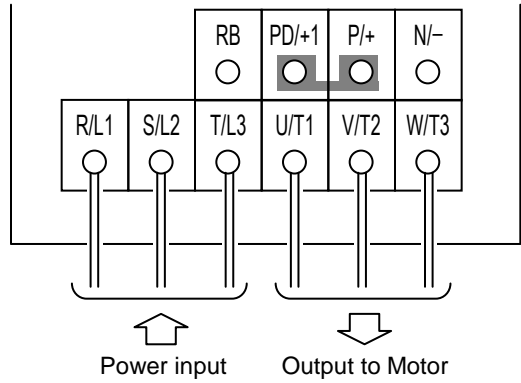
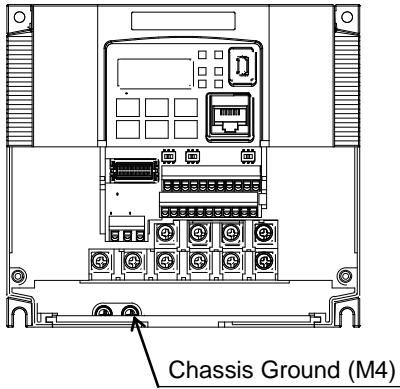

Three-phase 400V 7.5, 11kW

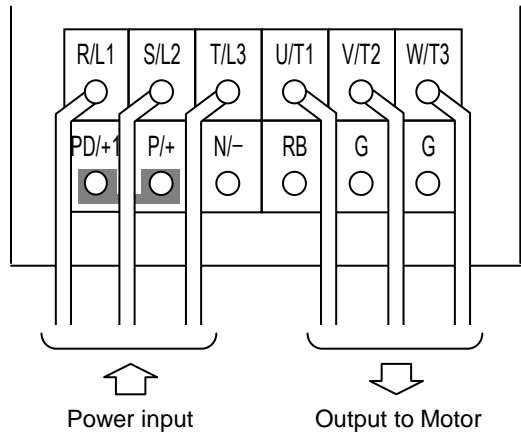
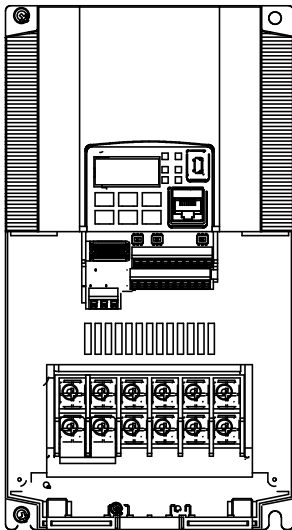

Three-phase 400V 15, 18.5kW

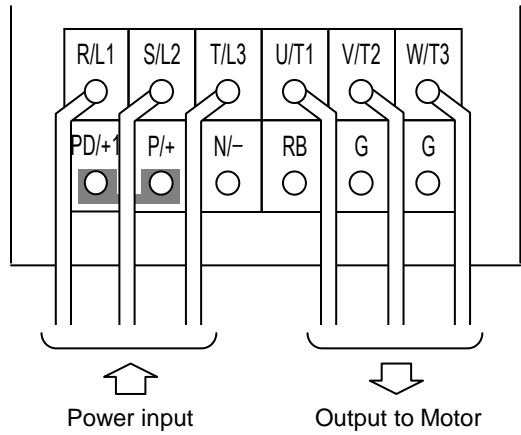
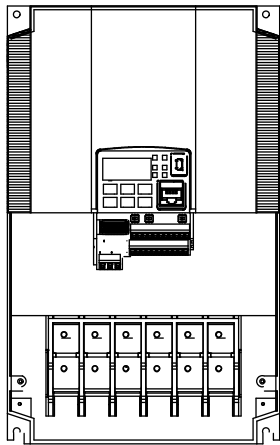

NOTE: An inverter powered by a portable power generator may receive a distorted power waveform, overheating the generator. In general, the generator capacity should be five times that of the inverter (kVA).

Using the Front Panel Keypad

Please take a moment to familiarize yourself with the keypad layout shown in the figure below. The display is used in programming the inverter's parameters, as well as monitoring specific parameter values during operation.

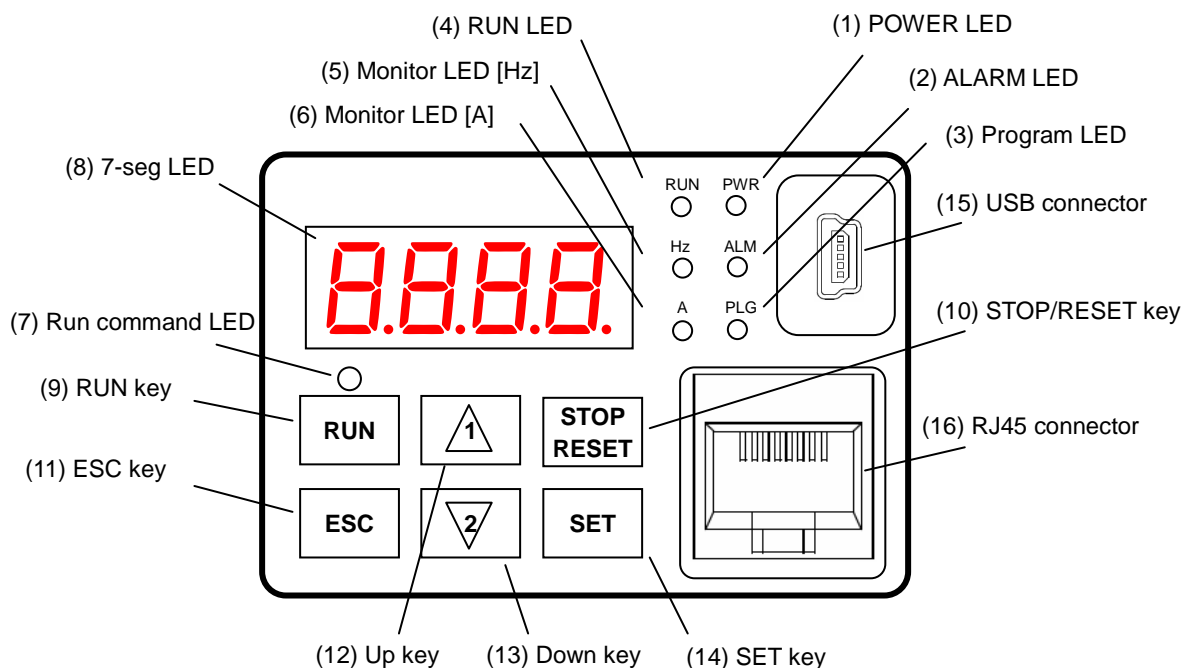

Key and Indicator Legend

Items	Contents
(1) POWER LED	Turns ON (Green) while the inverter is powered up.
(2) ALARM LED	Turns ON (Red) when the inverter trips.
(3) Program LED	Turns ON (Green) when the display shows changeable parameter. Blinks when there is a mismatch in setting.
(4) RUN LED	Turns ON (Green) when the inverter is driving the motor.
(5) Monitor LED [Hz]	Turns ON (Green) when the displayed data is frequency related.
(6) Monitor LED [A]	Turns ON (Green) when the displayed data is current related.
(7) Run command LED	Turns ON (Green) when a Run command is set to the operator. (Run key is effective.)
(8) 7-seg LED	Shows each parameter, monitors etc.
(9) RUN key	Makes inverter run.
(10) STOP/RESET key	Makes inverter decelerates to a stop. Reset the inverter when it is in trip situation
(11) ESC key	Go to the top of next function group, when a function mode is shown Cancel the setting and return to the function code, when a data is shown Moves the cursor to a digit left, when it is in digit-to-digit setting mode Pressing for 1 second leads to display data of d00 I , regardless of current display.
(12) Up key (13) Down key	Increase or decrease the data. Pressing the both keys at the same time gives you the digit-to-digit edit.
(14) SET key	Go to the data display mode when a function code is shown Stores the data and go back to show the function code, when data is shown. Moves the cursor to a digit right, when it is in digit-to-digit display mode
(15) USB connector	Connect USB connector (mini-B) for using PC communication
(16) RJ45 connector	Connect RJ45 jack for remote operator
(17) Remote Operator	Keys on the front panel don't work while the remote operator is connected ([STOP] can be validated). What to display on the 7-seg can be set with parameter b 150

Keys, Modes, and Parameters

The purpose of the keypad is to provide a way to change modes and parameters. The term *function* applies to both monitoring modes and parameters. These are all accessible through *function codes* that are primary 4-character codes. The various functions are separated into related groups identifiable by the left-most character, as the table shows.

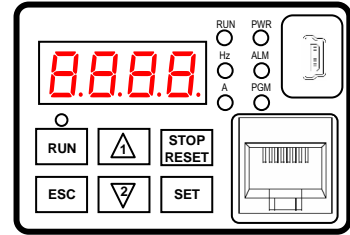

Function Group	Type (Category) of Function	Mode to Access	PRG LED Indicator
"d"	Monitoring functions	Monitor	○
"F"	Main profile parameters	Program	●
"A"	Standard functions	Program	●
"b"	Fine tuning functions	Program	●
"C"	Intelligent terminal functions	Program	●
"H"	Motor constant related functions	Program	●
"P"	Pulse train input, torque, EzSQ, and communication related functions	Program	●
"U"	User selected parameters	Program	●
"E"	Error codes	–	–

You can see from the following page how to monitor and/or program the parameters.

Keypad Navigation Map

The WL200 Series inverter drives have many programmable functions and parameters. The following pages will cover these in detail, but you need to access just a few items to perform the powerup test. The menu structure makes use of function codes and parameter codes to allow programming and monitoring with only a 4-digit display and keys and LEDs. So, it is important to become familiar with the basic navigation map of parameters and functions in the diagram below. You may later use this map as a reference.

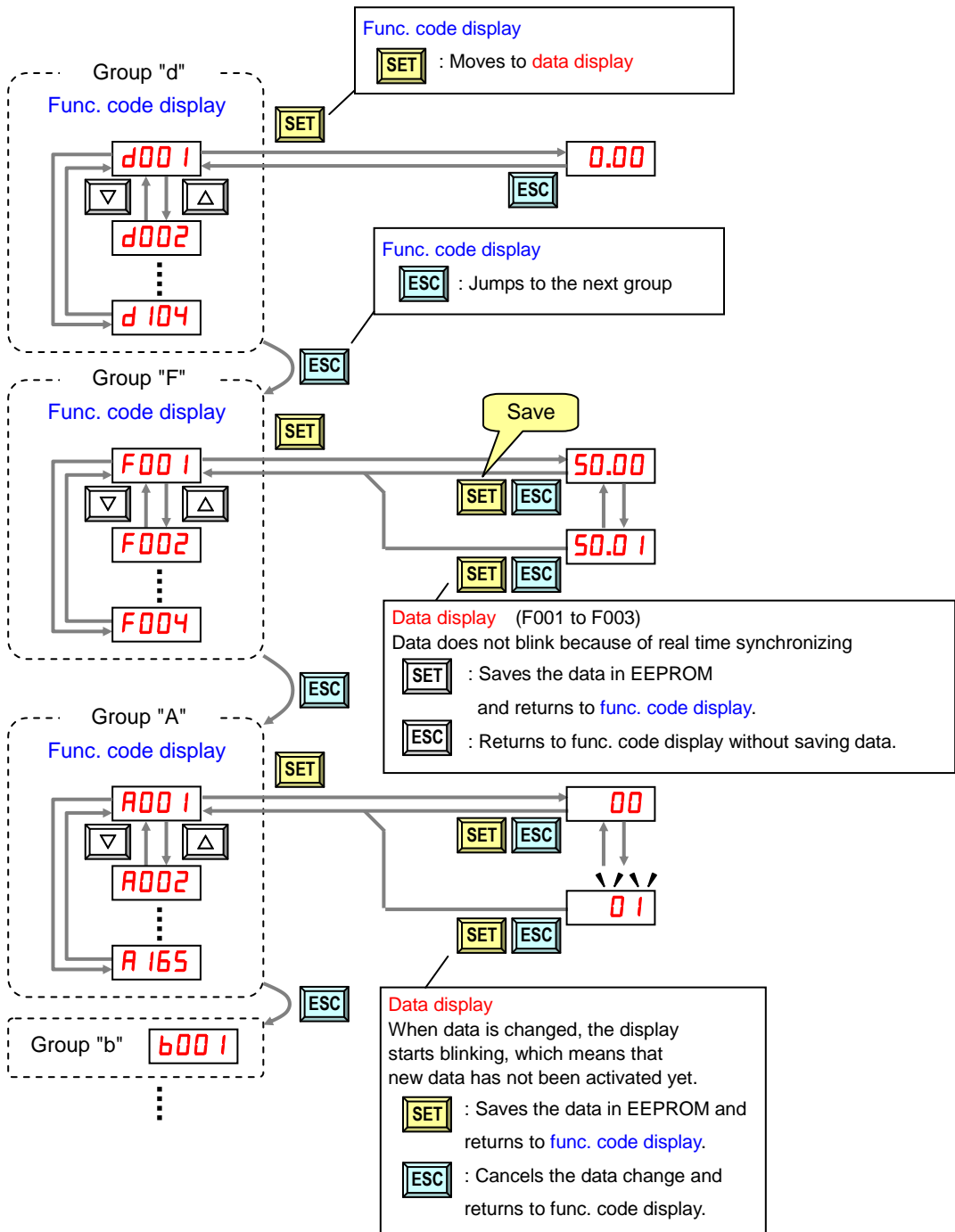

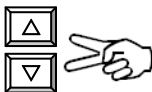

 Press the both up and down key at the same time in **func. code** or **data display**, then single-digit edit mode will be enabled.



NOTE: Pressing the [ESC] key will make the display go to the top of next function group, regardless the display contents. (e.g. *A02 1* → [ESC] → *b00 1*)

[Setting example]

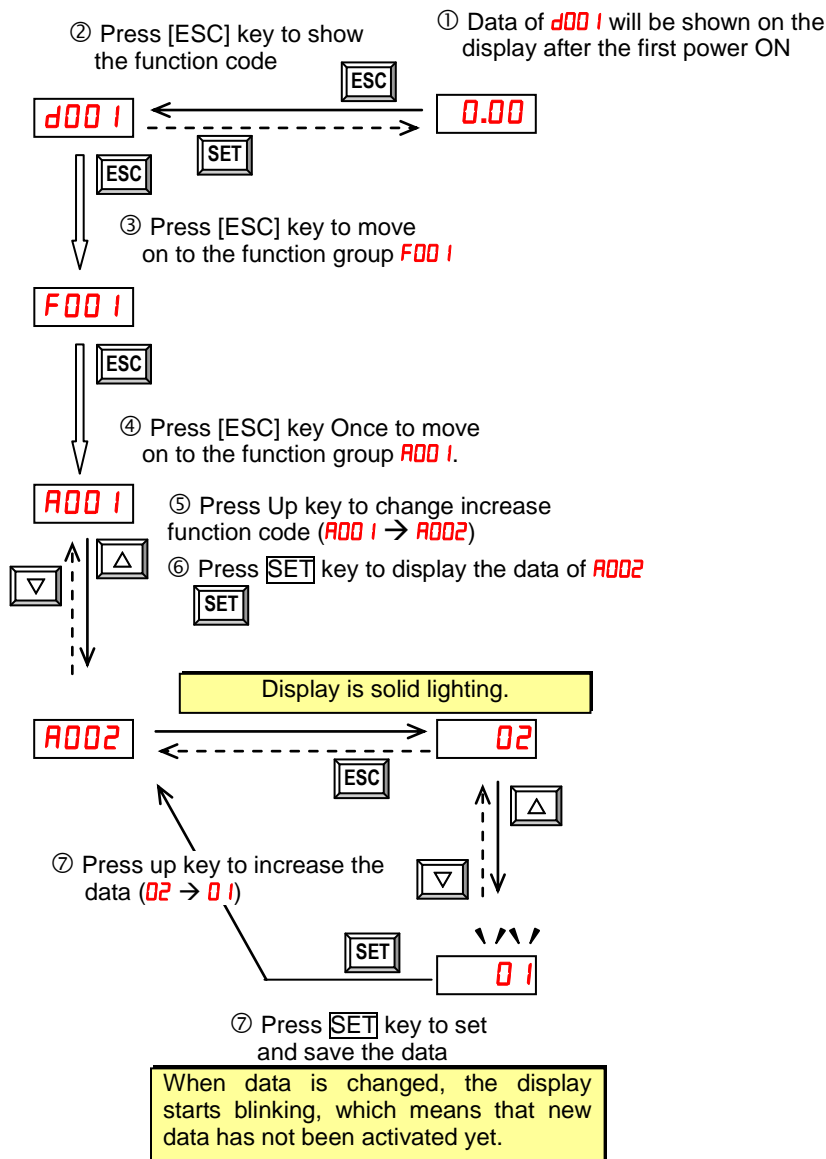
After power ON, changing from 0.00 display to change the *R002* (Run command source) data.



- [SET] :Fixes and stores the data and moves back to the function code
- [ESC] :Cancels the change and moves back to the function code



Function code *dxxx* are for monitor and not possible to change.
 Function codes *Fxxx* other than *F004* are reflected on the performance just after changing the data (before pressing [SET] key), and there will be no blinking.

	When a function code is shown...	When a data is shown...
[ESC] key	Move on to the next function group	Cancels the change and moves back to the function code
[SET] key	Move on to the data display	Fix and stores the data and moves back to the function code
[Δ] key	Increase function code	Increase data value
[▽] key	Decrease function code	Decrease data value

 Note

Keep pressing [ESC] key for more than 1 second leads to d001 display, regardless the display situation. But note that the display will circulates while keep pressing the [ESC] key because of the original function of the key.

(e.g. *F00 1* → *A00 1* → *b00 1* → *C00 1* → ... → displays *50.00* after 1 second)

Connecting to PLCs and Other Devices

Hitachi inverters (drives) are useful in many types of applications. During installation, the inverter keypad (or other programming device) will facilitate the initial configuration. After installation, the inverter will generally receive its control commands through the control logic connector or serial interface from another controlling device. In a simple application such as single-conveyor speed control, a Run/Stop switch and potentiometer will give the operator all the required control. In a sophisticated application, you may have a *programmable logic controller* (PLC) as the system controller, with several connections to the inverter.

It is not possible to cover all the possible types of application in this QRG. It will be necessary for you to know the electrical characteristics of the devices you want to connect to the inverter. Then, this section and the following sections on I/O terminal functions can help you quickly and safely connect those devices to the inverter.



CAUTION: It is possible to damage the inverter or other devices if your application exceeds the maximum current or voltage characteristics of a connection point.

The connections between the inverter and other devices rely on the electrical input/output characteristics at both ends of each connection, shown in the diagram to the right. The inverter's configurable inputs accept either a sourcing or sinking output from an external device (such as PLC). The following page shows the inverter's internal electrical component(s) at each I/O terminal. In some cases, you will need to insert a power source in the interface wiring.

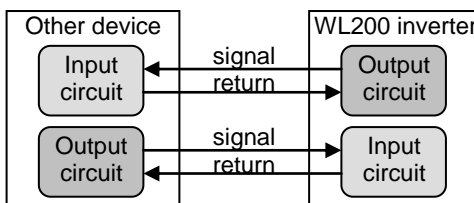

In order to avoid equipment damage and get your application running smoothly, we recommend drawing a schematic of each connection between the inverter and the other device. Include the internal components of each device in the schematic, so that it makes a complete circuit loop.

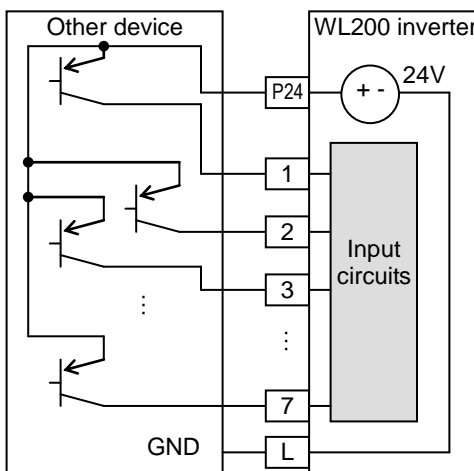

After making the schematic, then:

1. Verify that the current and voltage for each connection is within the operating limits of each device.
2. Make sure that the logic sense (active high or active low) of any ON/OFF connection is correct.
3. Check the zero and span (curve end points) for analog connections, and be sure the scale factor from input to output is correct.
4. Understand what will happen at the system level if any particular device suddenly loses power, or powers up after other devices.

Example Wiring Diagram

The schematic diagram below provides a general example of logic connector wiring, in addition to basic power and motor wiring converted in the preceding pages. The goal of this page is to help you determine the proper connections for the various terminals shown below for your application needs.

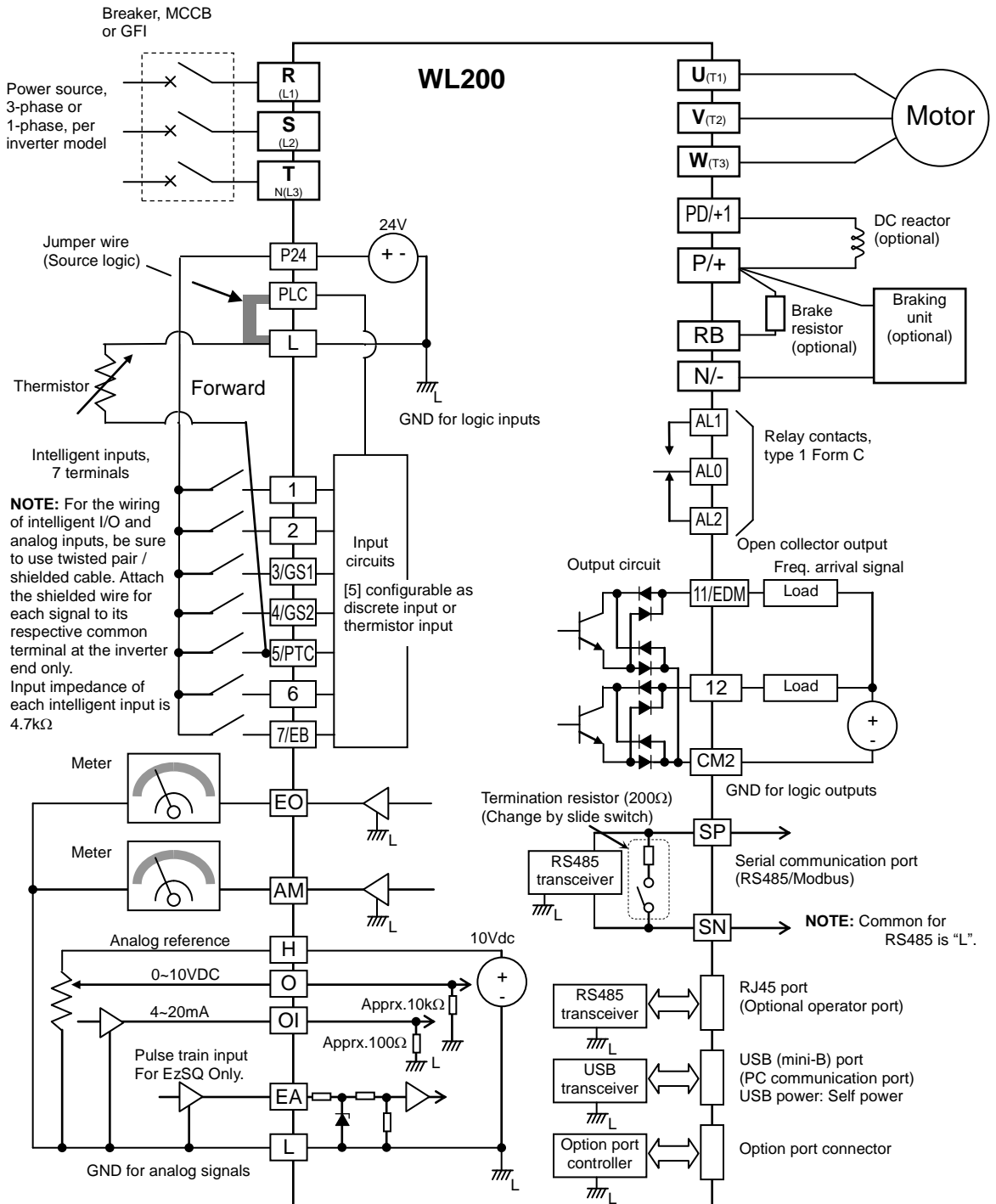

Control Logic Signal Specifications

The control logic connectors are located just behind the front housing cover. The relay contacts are just to the left of the logic connectors. Connector labeling is shown below.

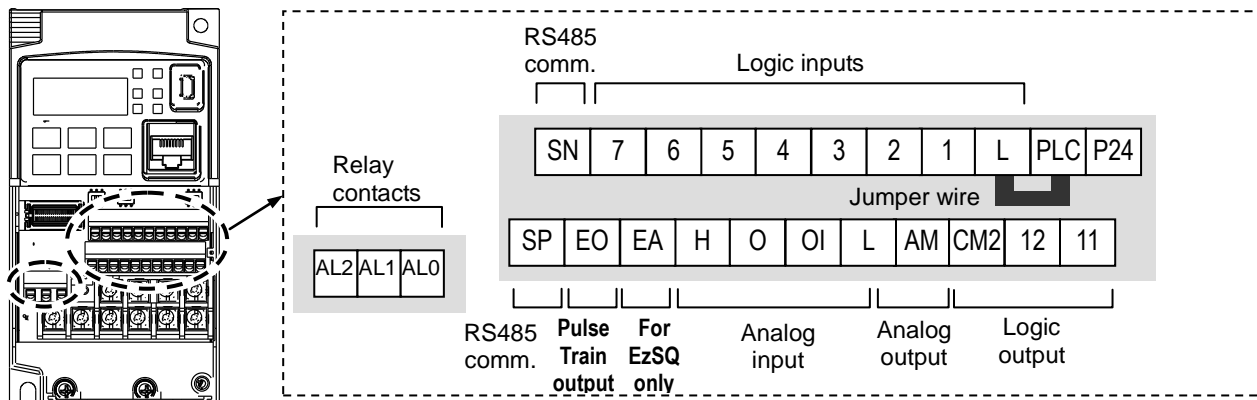

Terminal Name	Description	Ratings
P24	+24V for logic inputs	24VDC, 100mA. (do not short to terminal L)
PLC	Intelligent input common	To change to sink type, remove the jumper wire between [PLC] and [L], and connect it between [P24] and [PLC]. In this case, connecting [L] to [1]~[7] makes each input ON. Please remove the jumper wire when using external power supply.
1 2 3/GS1 4/GS2 5/PTC 6 7/EB	Discrete logic inputs (Terminal [3],[4],[5] and [7] have dual function. See following description and related pages for the details.)	27VDC max. (use PLC or an external supply referenced to terminal L)
GS1(3)	Safe stop input GS1	Functionality is based on ISO13849-1 *4
GS2(4)	Safe stop input GS2	
PTC(5)	Motor thermistor input	
EB(7)	Pulse train input B	2kHz max. Common is [PLC]
EA	Pulse train input A	For EzSQ Only. Common is [L]
L (in upper row) *1	GND for logic inputs	Sum of input [1]~[7] currents (return)
11/EDM	Discrete logic outputs [11] (Terminal [11] has dual function. See following description and related pages for the details.)	50mA max. ON state current, 27 VDC max. OFF state voltage Common is CM2 In case the EDM is selected, the functionality is based on ISO13849-1 4VDC max. ON state voltage depression
12	Discrete logic outputs [12]	50mA max. ON state current, 27 VDC max. OFF state voltage Common is CM2
CM2	GND for logic output	100 mA: [11], [12] current return
AM	Analog voltage output	0~10VDC 2mA maximum
EO	Pulse train output	10VDC 2mA maximum, 32kHz maximum
L (in bottom row) *2	GND for analog signals	Sum of [OI], [O], and [H] currents (return)
OI	Analog current input	4 to 19.6 mA range, 20 mA nominal, input impedance 100 Ω

Terminal Name	Description	Ratings
O	Analog voltage input	0 to 9.8 VDC range, 10 VDC nominal, input impedance 10 k Ω
H	+10V analog reference	10VDC nominal, 10mA max.
SP, SN	Serial communication terminal	For RS485 Modbus communication.
AL0, AL1, AL2 *3	Relay common contact	250VAC, 2.5A (R load) max. 250VAC, 0.2A (I load, P.F.=0.4) max. 100VAC, 10mA min. 30VDC, 3.0A (R load) max. 30VDC, 0.7A (I load, P.F.=0.4) max. 5VDC, 100mA min.

Note 1: The two terminals [L] are electrically connected together inside the inverter.

Note 2: We recommend using [L] logic GND (to the right) for logic input circuits and [L] analog GND (to the left) for analog I/O circuits.

Note 3: Refer to page 41 for details of trip signals.

Note 4: Refer to page 88, "Functional Safety" for details

Wiring sample of control logic terminal (Source logic)

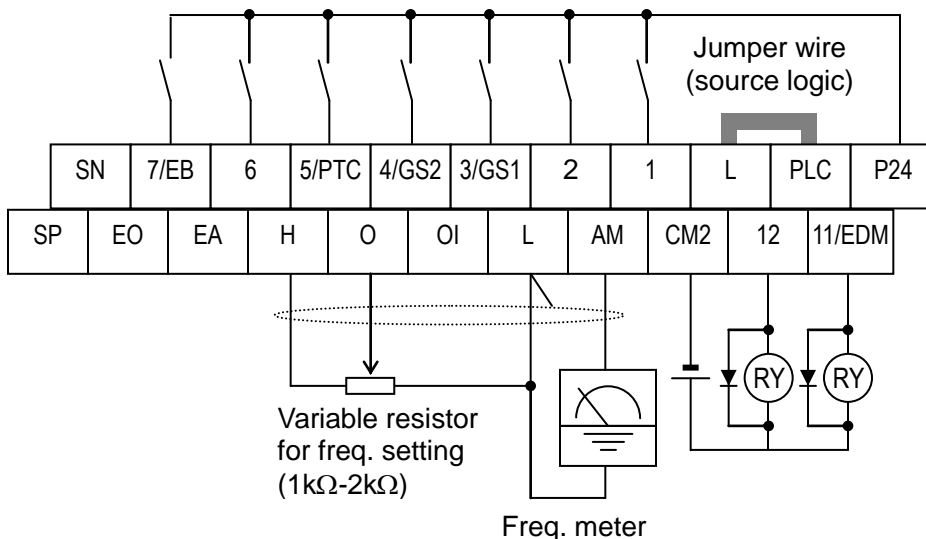

Note: If relay is connected to intelligent output, install a diode across the relay coil (reverse-biased) in order to suppress the turn-off spike.

Caution for intelligent terminals setting

Please avoid conducting below procedure, because if you follow procedure describe below, the inverter setting will be initialized.

- 1) Turning on power while [Intelligent input terminal 1/2/3 are ON] and [Intelligent input terminal 4/5/6/7 are OFF].
- 2) After 1)'s condition, turning off power.
- 3) After 2)'s condition, turning on power while [Intelligent input terminal 2/3/4 are ON] and [Intelligent input terminal 1/5/6/7 are OFF].

Sink/source logic of intelligent input terminals

Source or sink logic is switched by a jumper wire as below.

Source logic

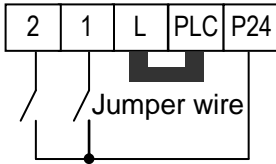

Sink logic

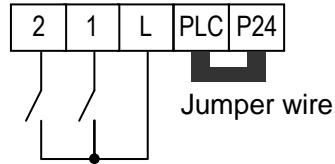

Wire size for control and relay terminals

Use wires within the specifications listed below. For safe wiring and reliability, it is recommended to use ferrules, but if solid or stranded wire is used, stripping length should be 8mm.

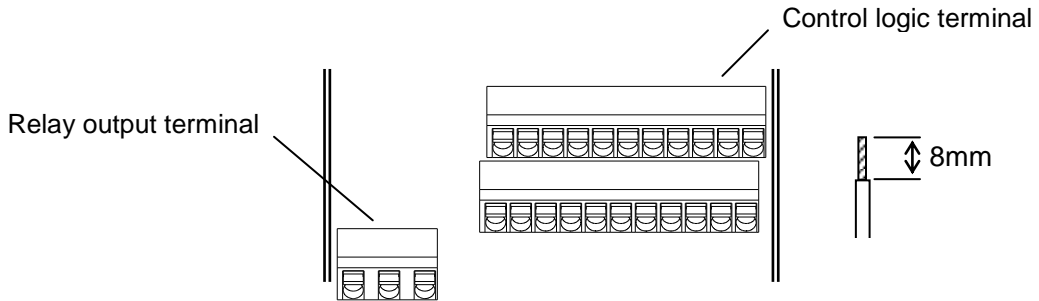

	Solid mm ² (AWG)	Stranded mm ² (AWG)	Ferrule mm ² (AWG)
Control logic terminal	0.2 to 1.5 (AWG 24 to 16)	0.2 to 1.0 (AWG 24 to 17)	0.25 to 0.75 (AWG 24 to 18)
Relay terminal	0.2 to 1.5 (AWG 24 to 16)	0.2 to 1.0 (AWG 24 to 17)	0.25 to 0.75 (AWG 24 to 18)

Recommended ferrule

For safe wiring and reliability, it is recommended to use following ferrules.

When you use an option mounted, please use a rod terminal without sleeve to wire so that to avoid hitting the option case.

Rod terminal with sleeve

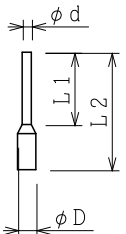
Wire size mm ² (AWG)	Model name of ferrule *	L1 [mm]	L2 [mm]	Φd [mm]	ΦD [mm]	
0.25 (24)	AI 0.25-8YE	8	12.5	0.8	2.0	
0.34 (22)	AI 0.34-8TQ	8	12.5	0.8	2.0	
0.5 (20)	AI 0.5-8WH	8	14	1.1	2.5	
0.75 (18)	AI 0.75-8GY	8	14	1.3	2.8	

Rod terminal without sleeve

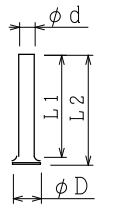
Wire size mm ² (AWG)	Model name of ferrule *	L1 [mm]	L2 [mm]	Φd [mm]	ΦD [mm]	
0.5 (20)	A 0,5 – 8	7.3	8	1.0	2.1	
0.75 (18)	A 0,75- 8	7.3	8	1.2	2.3	

* Supplier: Phoenix contact

Crimping pliers: CRIMPFOX UD 6-4 or CRIMPFOX ZA 3

How to connect?

- (1) Push down an orange actuating lever by a slotted screwdriver (width 2.5mm max.).
- (2) Plug in the conductor.
- (3) Pull out the screwdriver then the conductor is fixed.

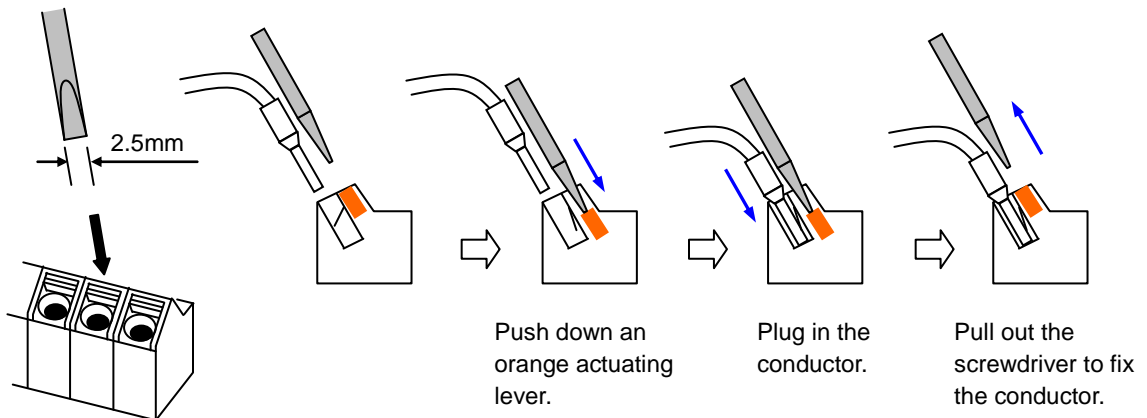

Intelligent Terminal Listing

Intelligent Inputs

The following table shows the list of the functions which can be assigned to each intelligent input. Please refer to the Instruction manual for the detail information.

Input Function Summary Table		
Symbol	Code	Function Name
FW	00	Forward Run/Stop
RV	01	Reverse Run/Stop
CF1	02	Multi-speed Select, Bit 0 (LSB)
CF2	03	Multi-speed Select, Bit 1
CF3	04	Multi-speed Select, Bit 2
CF4	05	Multi-speed Select, Bit 3 (MSB)
JG	06	Jogging
DB	07	External DC braking
SET	08	Set (select) 2nd Motor Data
2CH	09	2-stage Acceleration and Deceleration
FRS	11	Free-run Stop
EXT	12	External Trip
USP	13	Unattended Start Protection
CS	14	Commercial power source switchover
SFT	15	Software Lock
AT	16	Analog Input Voltage/Current Select
RS	18	Reset Inverter
PTC	19	PTC thermistor Thermal Protection
STA	20	Start (3-wire interface)
STP	21	Stop (3-wire interface)
F/R	22	FWD, REV (3-wire interface)
PID	23	PID Disable
PIDC	24	PID Reset
UP	27	Remote Control UP Function
DWN	28	Remote Control Down Function
UDC	29	Remote Control Data Clearing
OPE	31	Operator Control
SF1~SF7	32~38	Multi-speed Select, Bit operation Bit 1~7
OLR	39	Overload Restriction Source Changeover
BOK	44	Brake confirmation
LAC	46	LAD cancellation
ADD	50	ADD frequency enable
F-TM	51	Force Terminal Mode
KHC	53	Clear watt-hour data
MI1~MI7	56~62	General purpose input (1)~(7)
AHD	65	Analog command hold
GS1	77	STO1 input (Safety related signal)
GS2	78	STO2 input (Safety related signal)
485	81	Starting communication signal
PRG	82	Executing EzSQ program
HLD	83	Retain output frequency
ROK	84	Permission of Run command
DISP	86	Display limitation
NO	255	No assign

Intelligent Outputs

The following table shows the list of the functions which can be assigned to each intelligent input. Please refer to the Instruction manual for the detail information.

Output Function Summary Table		
Symbol	Code	Function Name
RUN	00	Run Signal
FA1	01	Frequency Arrival Type 1—Constant Speed
FA2	02	Frequency Arrival Type 2—Over frequency
OL	03	Overload Advance Notice Signal
OD	04	PID Deviation error signal
AL	05	Alarm Signal
FA3	06	Frequency Arrival Type 3—Set frequency
UV	09	Under voltage
RNT	11	Run Time Expired
ONT	12	Power ON time Expired
THM	13	Thermal Warning
BRK	19	Brake Release Signal
BER	20	Brake Error Signal
ZS	21	Zero Hz Speed Detection Signal
FA4	24	Frequency Arrival Type 4—Over frequency
FA5	25	Frequency Arrival Type 5—Set frequency
OL2	26	Overload Advance Notice Signal 2
ODc	27	Analog Voltage Input Disconnect Detection
OIDc	28	Analog Voltage Output Disconnect Detection
FBV	31	PID Second Stage Output
NDc	32	Network Disconnect Detection
LOG1~3	33~35	Logic Output Function 1~3
WAC	39	Capacitor Life Warning Signal
WAF	40	Cooling Fan Warning Signal
FR	41	Starting Contact Signal
OHF	42	Heat Sink Overheat Warning
LOC	43	Low load detection
MO1~3	44~46	General Output 1~3
IRDY	50	Inverter Ready Signal
FWR	51	Forward Operation
RVR	52	Reverse Operation
MJA	53	Major Failure Signal
WCO	54	Window Comparator for Analog Voltage Input
WCOI	55	Window Comparator for Analog Current Input
FREF	58	Frequency Command Source
REF	59	Run Command Source
SETM	60	2 nd Motor in operation
EDM	62	STO (Safe Torque Off) Performance Monitor (Output terminal 11 only)
OP	63	Option control signal
no	255	Not used

Using Intelligent Input Terminals

Terminals [1], [2], [3], [4], [5], [6] and [7] are identical, programmable inputs for general use. The input circuits can use the inverter's internal (isolated) +24V field supply or an external power supply. This section describes input circuits operation and how to connect them properly to switches or transistor outputs on field devices.

The WL200 inverter features selectable *sinking* or *sourcing* inputs. These terms refer to the connection to the external switching device—it either *sinks* current (from the input to GND) or *sources* current (from a power source) into the input. Note that the sink/source naming convention may be different in your particular country or industry. In any case, just follow the wiring diagrams in this section for your application.

The inverter has a jumper wire for configuring the choice of sinking or sourcing inputs. To access it, you must remove the front cover of the inverter housing. In the figure to the top right, the jumper wire is shown as attached to the logic terminal block (connector). If you need to change to the source type connection, remove the jumper wire and connect it as shown in the figure at the bottom right.

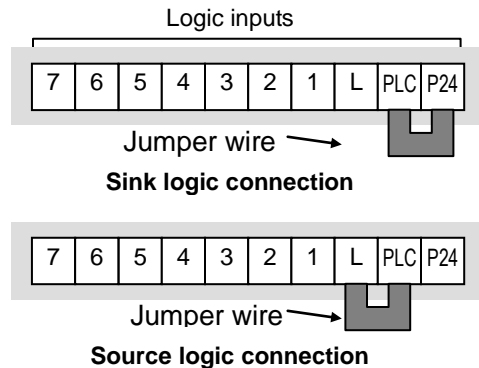

CAUTION: Be sure to turn OFF power to the inverter before changing the jumper wire position. Otherwise, damage to the inverter circuitry may occur.

[PLC] Terminal Wiring – The [PLC] terminal (Programmable Logic Control terminal) is named to include various devices that can connect to the inverter's logic inputs. In the figure to the right, note the [PLC] terminal and the jumper wire. Locating the jumper wire between [PLC] and [L] sets the input logic source type, which is the default setting for EU and US versions. In this case, you connect input terminal to [P24] to make it active. If instead you locate the jumper wire between [PLC] and [P24], the input logic will be sink type. In this case, you connect the input terminal to [L] to make it active.

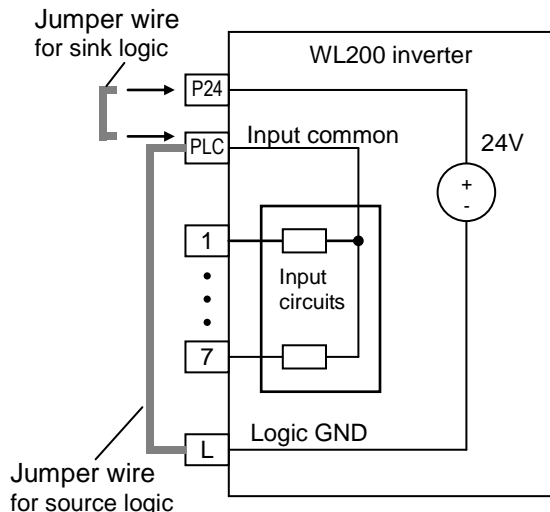

The wiring diagram on the following pages show the four combinations of using sourcing or sinking inputs, and using the internal or an external DC supply.

The two diagrams below input wiring circuits using the inverter's internal +24V supply. Each diagram shows the connection for simple switches, or for a field device with transistor outputs. Note that in the lower diagram, it is necessary to connect terminal [L] only when using the field device with transistors. Be sure to use the correct connection of the jumper wire shown for each wiring diagram.

Sinking Inputs, Internal Supply

Jumper wire = [PLC] – [P24] position

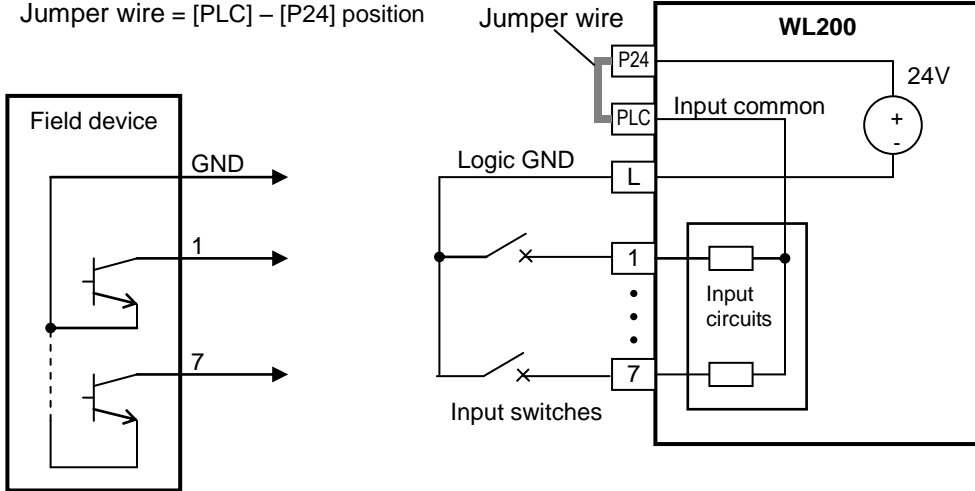

Open collector outputs, NPN transistors

Sourcing Inputs, Internal Supply

Jumper wire = [PLC] – [L] position

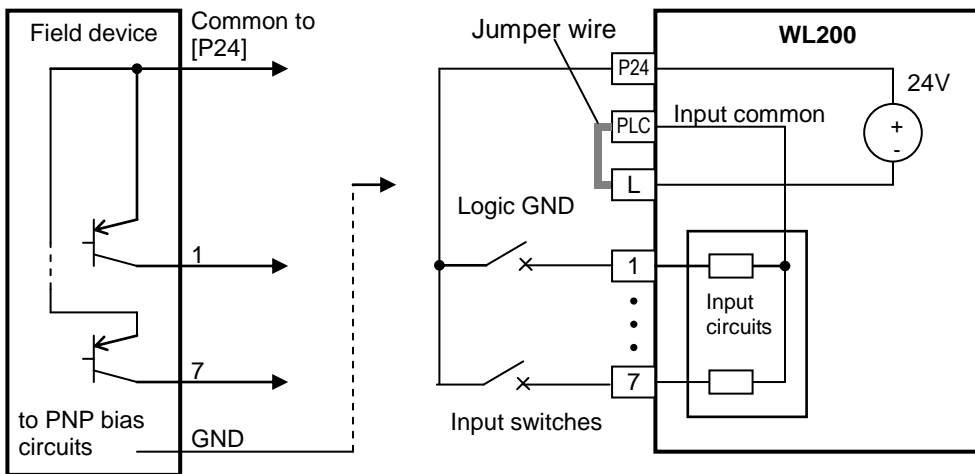

PNP transistor sourcing outputs

The two diagrams below show input wiring circuits using an external supply. If using the "Sinking Inputs, External Supply" in below wiring diagram, be sure to remove the jumper wire, and use a diode (*) with the external supply. This will prevent a power supply contention in case the jumper wire is accidentally placed in the incorrect position. For the "Sourcing Inputs, External Supply", please connect the jumper wire as drawn in the diagram below.

Sinking Inputs, External Supply

Jumper wire = Removed

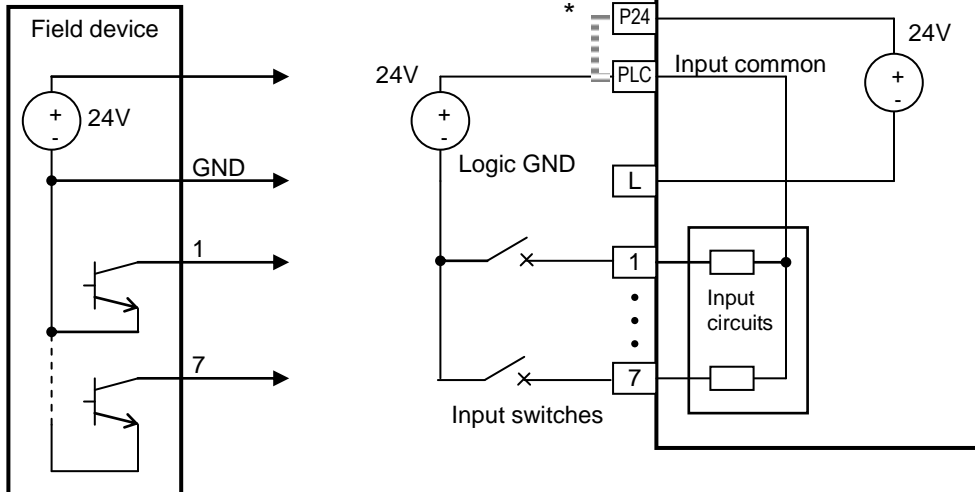

Open collector outputs,
NPN transistors

* Note: Make sure to remove the jumper wire in case of using an external power supply.

Sourcing Inputs, External Supply

Jumper wire = Removed

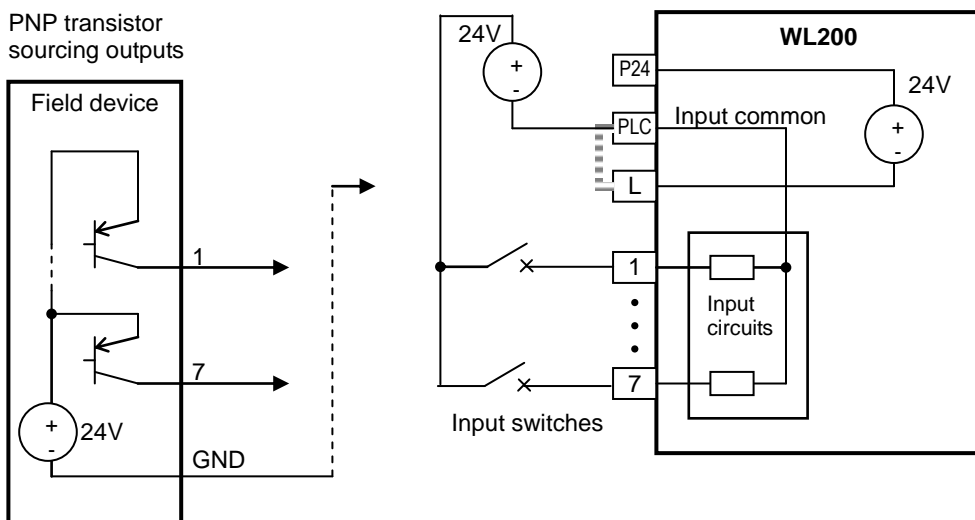

PNP transistor
sourcing outputs



CAUTION: Be sure to connect diode in between "P24" and "PLC" when connecting plural inverters with digital input wiring in common.

By having ability inverter doesn't block the current flowing into itself when it is not powered. This may cause the closed circuit when two or more inverters are connected to common I/O wiring as shown below to result in unexpected turning the on the input. To avoid this closed circuit, please put the diode (rated:50V/0.1A) in the path as described below.

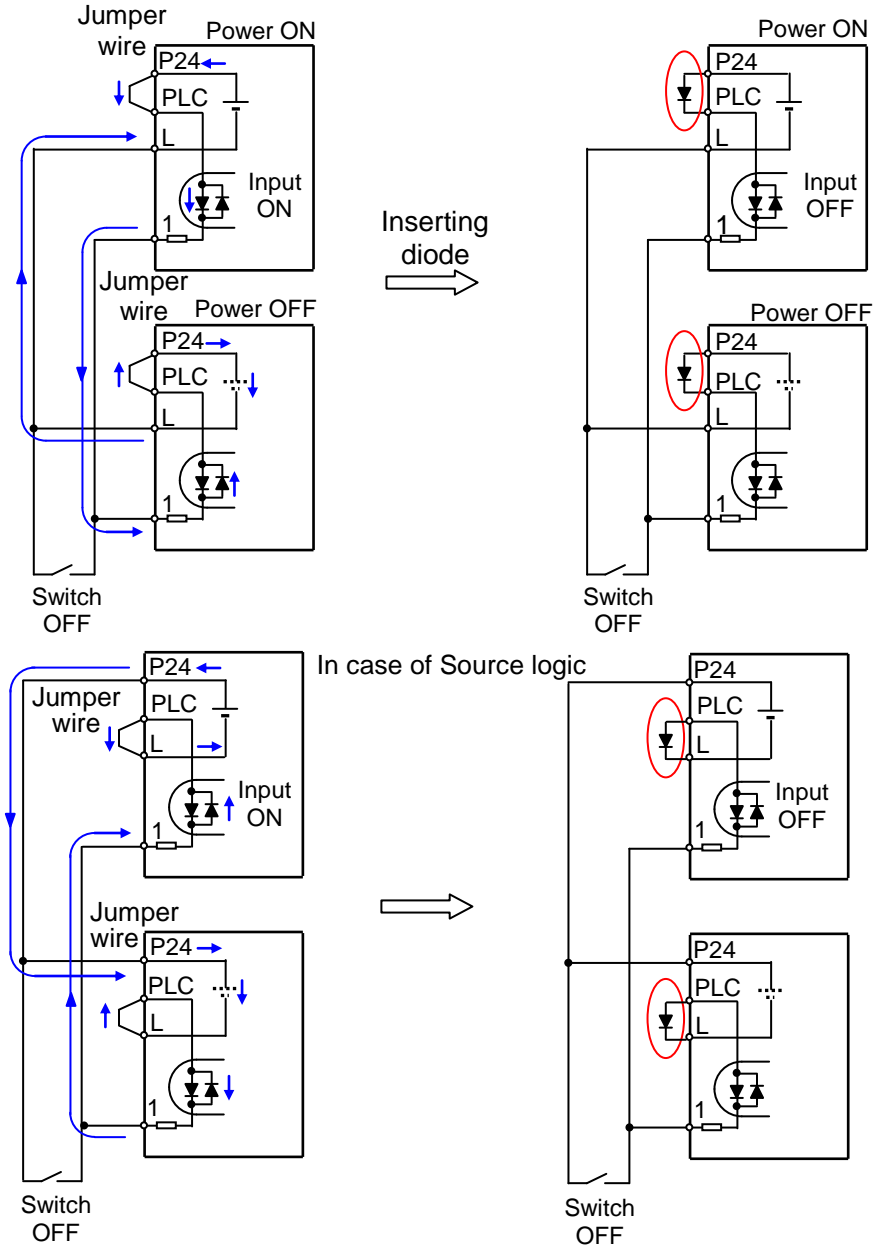

Forward Run/Stop and Reverse Run/Stop Commands:

When you input the Run command via the terminal [FW], the inverter executes the Forward Run command (high) or Stop command (low). When you input the Run command via the terminal [RV], the inverter executes the Reverse Run command (high) or Stop command (low).

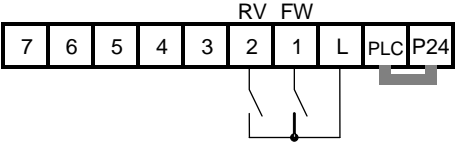
Option Code	Terminal Symbol	Function Name	State	Description
00	FW	Forward Run/Stop	ON	Inverter is in Run Mode, motor runs forward
			OFF	Inverter is in Stop Mode, motor stops
01	RV	Reverse Run/Stop	ON	Inverter is in Run Mode, motor runs reverse
			OFF	Inverter is in Stop Mode, motor stops
Valid for inputs:		C00 1~C007		Example (default input configuration shown see page 66): 
Required settings:		A002 = 01		
Notes: <ul style="list-style-type: none"> When the Forward Run and Reverse Run commands are active at the same time, the inverter enters the Stop Mode. When a terminal associated with either [FW] or [RV] function is configured for <i>normally closed</i>, the motor starts rotation when that terminal is disconnected or otherwise has no input voltage. 				
				See I/O specs on page 23, 24 .



NOTE: The parameter **F004**, Keypad Run Key Routing, determines whether the single Run key issues a Run FWD command or Run REV command. However, it has no effect on the [FW] and [RV] input terminal operation.



WARNING: If the power is turned ON and the Run command is already active, the motor starts rotation and is dangerous! Before turning power ON, confirm that the Run command is not active.

Multi-Speed Select ~Binary Operation

The inverter can store up to 16 different target frequencies (speeds) that the motor output uses for steady-state run condition. These speeds are accessible through programming four of the intelligent terminals as binary-encoded inputs CF1 to CF4 per the table to the right. These can be any of the six inputs, and in any order. You can use fewer inputs if you need eight or fewer speeds.

Multi-speed	Input Function			
	CF4	CF3	CF2	CF1
Speed 0	0	0	0	0
Speed 1	0	0	0	1
Speed 2	0	0	1	0
Speed 3	0	0	1	1
Speed 4	0	1	0	0
Speed 5	0	1	0	1
Speed 6	0	1	1	0
Speed 7	0	1	1	1
Speed 8	1	0	0	0
Speed 9	1	0	0	1
Speed 10	1	0	1	0
Speed 11	1	0	1	1
Speed 12	1	1	0	0
Speed 13	1	1	0	1
Speed 14	1	1	1	0
Speed 15	1	1	1	1



NOTE: When choosing a subset of speeds to use, always start at the top of the table, and with the least-significant bit: CF1, CF2, etc.

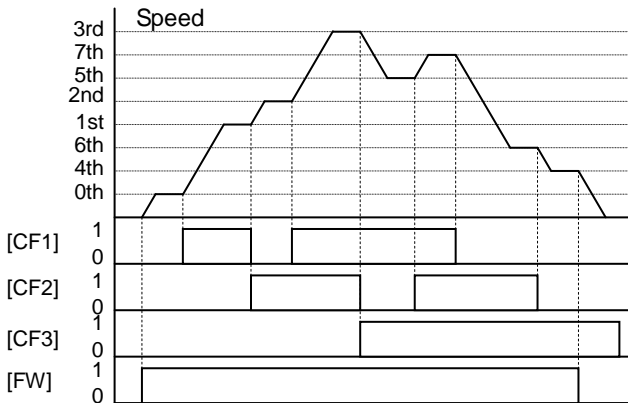

The example with eight speeds in the figure below shows how input switches configured for CF1–CF4 functions can change the motor speed in real time.

NOTE: Speed 0 depends on **ADD 1** parameter value.

Option Code	Terminal Symbol	Function Name	State	Description
02	CF1	Multi-speed Select, Bit 0 (LSB)	ON	Binary encoded speed select, Bit 0, logical 1
			OFF	Binary encoded speed select, Bit 0, logical 0
03	CF2	Multi-speed Select, Bit 1	ON	Binary encoded speed select, Bit 1, logical 1
			OFF	Binary encoded speed select, Bit 1, logical 0
04	CF3	Multi-speed Select, Bit 2	ON	Binary encoded speed select, Bit 2, logical 1
			OFF	Binary encoded speed select, Bit 2, logical 0
05	CF4	Multi-speed Select, Bit 3 (MSB)	ON	Binary encoded speed select, Bit 3, logical 1
			OFF	Binary encoded speed select, Bit 3, logical 0
Valid for inputs:		C00 1~C007		Example (some CF inputs require input configuration; some are default inputs):
Required settings		F00 1, A00 1=02, A020 to A035		
Notes: <ul style="list-style-type: none"> When programming the multi-speed settings, be sure to press the SET key each time and then set the next multi-speed setting. Note that when the key is not pressed, no data will be set. When a multi-speed setting more than 50Hz (60Hz) is to be set, it is necessary to program the maximum frequency A004 high enough to allow that speed 				
				See I/O specs on page 23, 24 .

Two Stage Acceleration and Deceleration

When terminal [2CH] is turned ON, the inverter changes the rate of acceleration and deceleration from the initial settings (**F002** and **F003**) to use the second set of acceleration/ deceleration values. When the terminal is turned OFF, the inverter is returned to the original acceleration and deceleration time (**F002** acceleration time 1, and **F003** deceleration time 1). Use **A092** (acceleration time 2) and **A093** (deceleration time 2) to set the second stage acceleration and deceleration times.

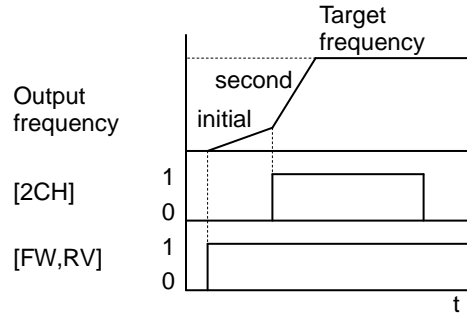

In the graph shown above, the [2CH] becomes active during the initial acceleration. This causes the inverter to switch from using acceleration 1 (**F002**) to acceleration 2 (**A092**).

Option Code	Terminal Symbol	Function Name	State	Description
09	2CH	Two-stage Acceleration and Deceleration	ON	Frequency output uses 2nd-stage acceleration and deceleration values
			OFF	Frequency output uses the initial acceleration 1 and deceleration 1 values
Valid for inputs:		C00 1~C007		Example (requires input configuration see page 66):
Required settings		A092, A093, A094=00		
Notes: <ul style="list-style-type: none"> Function A094 selects the method for second stage acceleration. It must be set = 00 to select the input terminal method in order for the [2CH] terminal assignment to operate. 				
				<p>See I/O specs on page 23, 24.</p>

Unattended Start Protection

If the Run command is already set when power is turned ON, the inverter starts running immediately after powerup. The Unattended Start Protection (USP) function prevents that automatic startup, so that the inverter *will not* run without outside intervention. When USP is active and you need to reset an alarm and resume running, either turn the Run command OFF, or perform a reset operation by the terminal [RS] input or the keypad Stop/reset key.

In the figure below, the [USP] feature is enabled. When the inverter power turns ON, the motor does not start, even though the Run command is already active. Instead, it enters the USP trip state, and displays **E 13** error code. This requires outside intervention to reset the alarm by turning OFF the Run command per this example (or applying a reset). Then the Run command can turn ON again and start the inverter output.

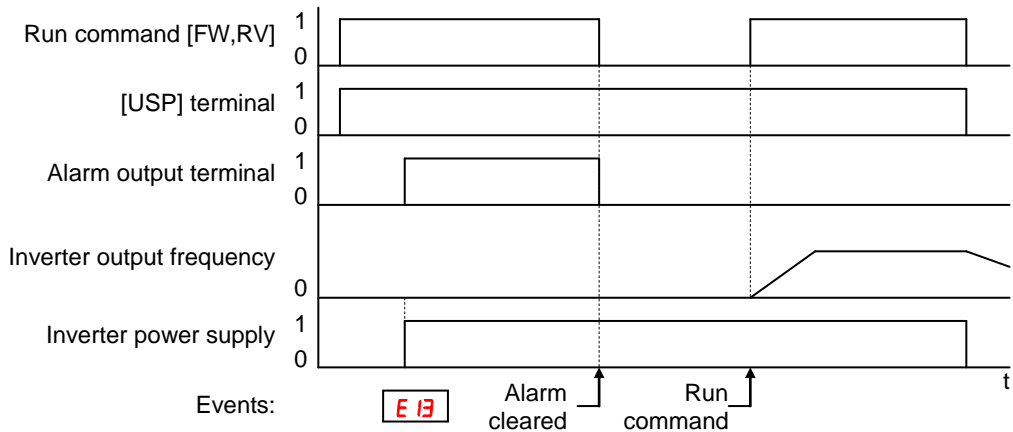

Option Code	Terminal Symbol	Function Name	State	Description
13	USP	Unattended Start Protection	ON	On powerup, the inverter will not resume a Run command (mostly used in the US)
			OFF	On powerup, the inverter will resume a Run command that was active before power loss
Valid for inputs:		C00 1~C007	Example (requires input configuration see page 66):	
Required settings		(none)		
Notes:		<ul style="list-style-type: none"> Note that when a USP error occurs and it is canceled by a reset from a [RS] terminal input, the inverter restarts running immediately. Even when the trip state is canceled by turning the terminal [RS] ON and OFF after an under voltage protection E09 occurs, the USP function will be performed. When the running command is active immediately after the power is turned ON, a USP error will occur. When this function is used, wait for at least three (3) seconds after the powerup to generate a Run command. 		<p>See I/O specs on page 23, 24.</p>

Reset Inverter

The [RS] terminal causes the inverter to execute the reset operation. If the inverter is in Trip Mode, the reset cancels the Trip state. When the signal [RS] is turned ON and OFF, the inverter executes the reset operation. The minimum pulse width for [RS] must be 12 ms or greater. The alarm output will be cleared within 30 ms after the onset of the Reset command.

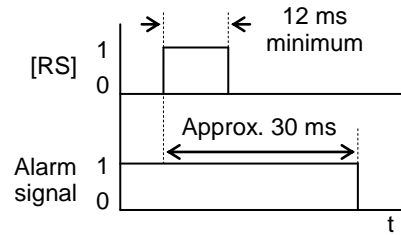

WARNING: After the Reset command is given and the alarm reset occurs, the motor will restart suddenly if the Run command is already active. Be sure to set the alarm reset after verifying that the Run command is OFF to prevent injury to personnel.

Option Code	Terminal Symbol	Function Name	State	Description
I8	RS	Reset Inverter	ON	The motor output is turned OFF, the Trip Mode is cleared (if it exists), and powerup reset is applied
			OFF	Normal power ON operation
Valid for inputs:		C00 1~C007	Example (default input configuration shown see page 66):	
Required settings		(none)		
Notes:				
<ul style="list-style-type: none"> While the control terminal [RS] input is ON, the keypad displays alternating segments. After RS turns OFF, the display recovers automatically. Pressing the Stop/Reset key of the digital operator can generate a reset operation only when an alarm occurs. 				
<p>See I/O specs on page 23, 24.</p>				
<ul style="list-style-type: none"> A terminal configured with the [RS] function can only be configured for normally open operation. The terminal cannot be used in the normally closed contact state. When input power is turned ON, the inverter performs the same reset operation as it does when a pulse on the [RS] terminal occurs. The Stop/Reset key on the inverter is only operational for a few seconds after inverter powerup when a hand-held remote operator is connected to the inverter. If the [RS] terminal is turned ON while the motor is running, the motor will be free running (coasting). If you are using the output terminal OFF delay feature (any of C 145, C 147, C 149 > 0.0 sec.), the [RS] terminal affects the ON-to-OFF transition slightly. Normally (without using OFF delays), the [RS] input causes the motor output and the logic outputs to turn OFF together, immediately. However, when any output uses an OFF delay, then after the [RS] input turns ON, that output will remain ON for an additional 1 sec. period (approximate) before turning OFF. 				

Using Intelligent Output Terminals

Run Signal

When the [RUN] signal is selected as an intelligent output terminal, the inverter outputs a signal on that terminal when it is in Run Mode. The output logic is active low, and is the open collector type (switch to ground).

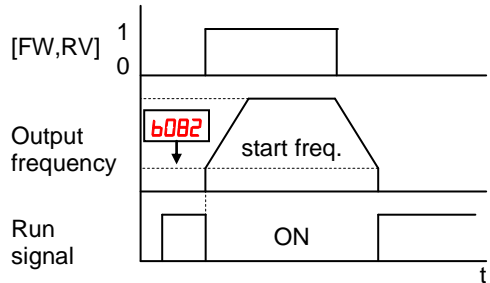

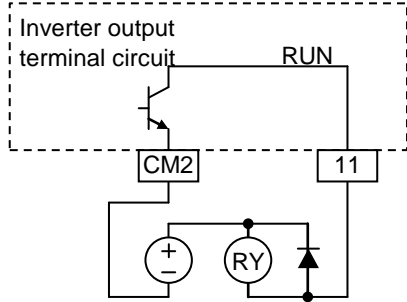
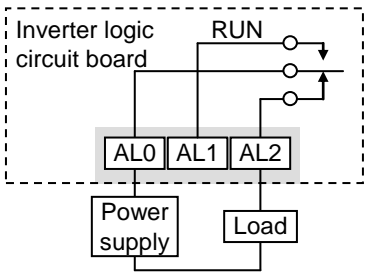
Option Code	Terminal Symbol	Function Name	State	Description
00	RUN	Run Signal	ON	when inverter is in Run Mode
			OFF	when inverter is in Stop Mode
Valid for inputs:		11, 12, AL0 – AL2		Example for terminal [11] (default output configuration shown see page 66): 
Required settings		(none)		
Notes: <ul style="list-style-type: none"> The inverter outputs the [RUN] signal whenever the inverter output exceeds the start frequency specified by parameter b082. The start frequency is the initial inverter output frequency when it turns ON. The example circuit for terminal [11] drives a relay coil. Note the use of a diode to prevent the negative going turn-off spike generated by the coil from damaging the inverter's output transistor. 				
				Example for terminal [AL0], [AL1], [AL2] (requires output configuration see page 66): 
				See I/O specs on page 23, 24 .

Frequency Arrival Signals

The *Frequency Arrival* group of outputs helps coordinate external systems with the current velocity profile of the inverter. As the name implies, output [FA1] turns ON when the output frequency arrives at the standard set frequency (parameter F001). Output [FA2] relies on programmable accel/ decel thresholds for increased flexibility. For example, you can have an output turn ON at one frequency during acceleration, and have it turn OFF at a different frequency during deceleration. All transitions have hysteresis to avoid output chatter if the output frequency is near one of the thresholds.

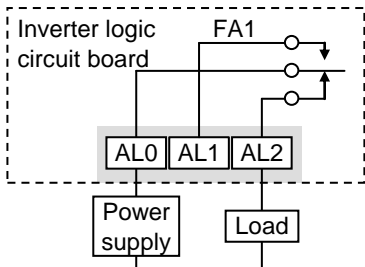
Option Code	Terminal Symbol	Function Name	State	Description
01	FA1	Frequency Arrival Type 1 – Constant Speed	ON	when output to motor is at the constant frequency
			OFF	when output to motor is OFF, or in any acceleration or deceleration ramp
02	FA2	Frequency Arrival Type 2 – Over frequency	ON	when output to motor is at or above the set frequency thresholds for, even in acceleration or decel ramps
			OFF	when output to motor is OFF, or during accel or decel before the respective thresholds are crossed
05	FA3	Frequency Arrival Type 3 – Set frequency	ON	when output to motor is at the set frequency
			OFF	when output to motor is OFF, or in any acceleration or deceleration ramp
24	FA4	Frequency Arrival Type 4 – Over frequency (2)	ON	when output to motor is at or above the set frequency thresholds for, even in acceleration or decel ramps
			OFF	when output to motor is OFF, or during accel or decel before the respective thresholds are crossed
25	FA5	Frequency Arrival Type 5 – Set frequency (2)	ON	when output to motor is at the set frequency
			OFF	when output to motor is OFF, or in any acceleration or deceleration ramp
Valid for inputs:		11, 12, AL0 – AL2		Example for terminal [11] (default output configuration shown see page 66):
Required settings		C042, C043, C045, C046,		
Notes: <ul style="list-style-type: none"> For most applications you will need to use only one type of frequency arrival outputs (see examples). However, it is possible to assign both output terminals to output functions [FA1] and [FA2] For each frequency arrival threshold, the output anticipates the threshold (turns ON early) by 1.0% of maximum frequency The output turns OFF as the output frequency moves away from the threshold, delayed by 2.0% of maximum frequency The example circuit for terminal [11] drives a relay coil. Note the use of a diode to prevent the negative going turn-off spike generated by the coil from damaging the inverter's output transistor 				
Example for terminal [AL0], [AL1], [AL2] (requires output configuration see page 66): 				
See I/O specs on page 23, 24 .				

Frequency arrival output [FA1] uses the standard output frequency (parameter F001) as the threshold for switching. In the figure to the right, Frequency Arrival [FA1] turns ON when the output frequency gets within F_{on} Hz below or F_{on} Hz above the target constant frequency, where F_{on} is 1% of the set maximum frequency and F_{off} is 2% of the set maximum frequency. This provides hysteresis that prevents output chatter near the threshold value. The hysteresis effect causes the output to turn ON slightly *early* as the speed approaches the threshold. Then the turn-OFF point is slightly *delayed*. Note the active low nature of the signal, due to the open collector output.

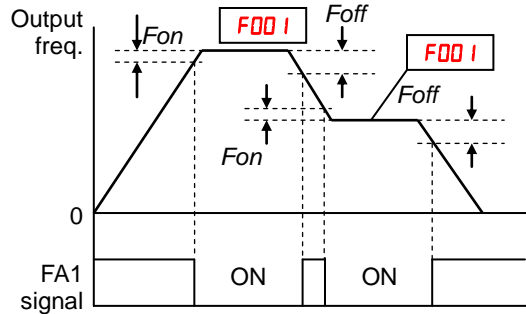

$F_{on}=1\%$ of max. frequency
 $F_{off}=2\%$ of max. frequency

Frequency arrival output [FA2/FA4] works the same way; it just uses two separate thresholds as shown in the figure to the right. These provide for separate acceleration and deceleration thresholds to provide more flexibility than for [FA1]. [FA2/FA4] uses **C042/C045** during acceleration for the ON threshold, and **C043/C046** during deceleration for the OFF threshold. This signal also is active low. Having different accel and decel thresholds provides an asymmetrical output function. However, you can use equal ON and OFF thresholds, if desired.

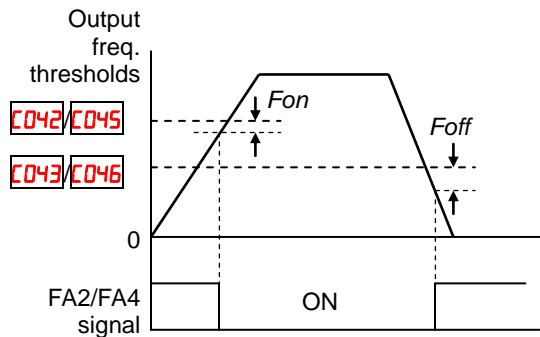

$F_{on}=1\%$ of max. frequency
 $F_{off}=2\%$ of max. frequency

As for [FA3/FA5] signal, the basic meaning of " F_{on}/F_{off} " is the same as above.

And, "**C042/C045** and **C043/C046** are correlated with [FA2/FA4] signal.

Basically, the meaning of " F_{on}/F_{off} " in this case is the same as above examples, but there are slight differences from the usage of [FA2/FA4] signal.

In acceleration status, [FA3/FA5] signal becomes ON from ("**C042/C045**" - " F_{on} ") to ("**C042/C045**" + " F_{off} ").

In deceleration status, [FA3/FA5] signal becomes ON from ("**C043/C046**" + " F_{on} ") to ("**C043/C046**" - " F_{off} ").

There is no [FA3/FA5] between "ONs" in the figure, because frequency arrival output is out of the area defined by the sets of parameters.

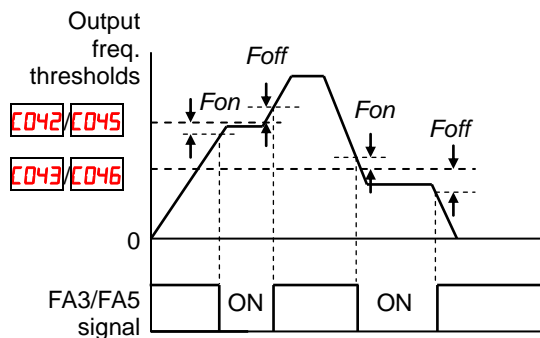

$F_{on}=1\%$ of max. frequency
 $F_{off}=2\%$ of max. frequency

Alarm Signal

The inverter alarm signal is active when a fault has occurred and it is in the Trip Mode (refer to the diagram at right). When the fault is cleared the alarm signal becomes inactive.

We must make a distinction between the alarm *signal* AL and the alarm relay *contacts* [AL0], [AL1] and [AL2]. The signal AL is a logic function, which you can assign to the open collector output terminals [11], [12], or the relay outputs.

The most common (and default) use of the relay is for AL, thus the labeling of its terminals. Use an open collector output (terminal [11] or [12]) for a low-current logic signal interface or to energize a small relay (50 mA maximum). Use the relay output to interface to higher voltage and current devices (10 mA minimum).

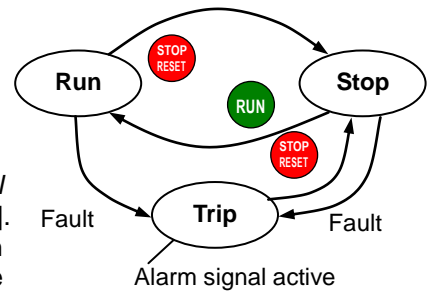

Option Code	Terminal Symbol	Function Name	State	Description
05	AL	Alarm Signal	ON	when an alarm signal has occurred and has not been cleared
			OFF	when no alarm has occurred since the last clearing of alarm(s)
Valid for inputs:		11, 12, AL0 – AL2		Example for terminal [11] (requires output configuration see page 66):
Required settings		C031, C032, C036		
<p>Notes:</p> <ul style="list-style-type: none"> By default, the relay is configured as normally closed (C036=0). Refer to the next page for an explanation. In the default relay configuration, an inverter power loss turns ON the alarm output. the alarm signal remains ON as long as the external control circuit has power. When the relay output is set to normally closed, a time delay of less than 2 seconds occurs after powerup before the contact is closed. Terminals [11] and [12] are open collector outputs, so the electric specifications of [AL] are different from the contact output terminals [AL0], [AL1], [AL2]. This signal output has the delay time (300 ms nominal) from the fault alarm output. The relay contact specifications are in “Control Logic Signal Specifications” on page 25. The contact diagrams for different conditions are on the next page. 				
<p>Example for terminal [AL0], [AL1], [AL2] (default output configuration shown see page 66):</p>				
<p>See I/O specs on page 23, 24.</p>				

The alarm relay output can be configured in two main ways:

- Trip/Power Loss Alarm** – The alarm relay is configured as normally closed (**C036=0 1**) by default, shown below (left). An external alarm circuit that detects broken wiring also as an alarm connects to [AL0] and [AL1]. After powerup and short delay (< 2 seconds), the relay energizes and the alarm circuit is OFF. Then, either an inverter trip event or an inverter power loss will de-energize the relay and open the alarm circuit
- Trip Alarm** – Alternatively, you can configure the relay as normally open (**C036=00**), shown below (right). An external alarm circuit that detects broken wiring also as an alarm connects to [AL0] and [AL2]. After powerup, the relay energizes only when an inverter trip event occurs, opening the alarm circuit. However, in this configuration, an inverter power loss does not open the alarm circuit.

Be sure to use the relay configuration that is appropriate for your system design. Note that the external circuits shown assume that a closed circuit = no alarm condition (so that a broken wire also causes an alarm). However, some systems may require a closed circuit = alarm condition. In that case, then use the opposite terminal [AL1] or [AL2] from the ones shown.

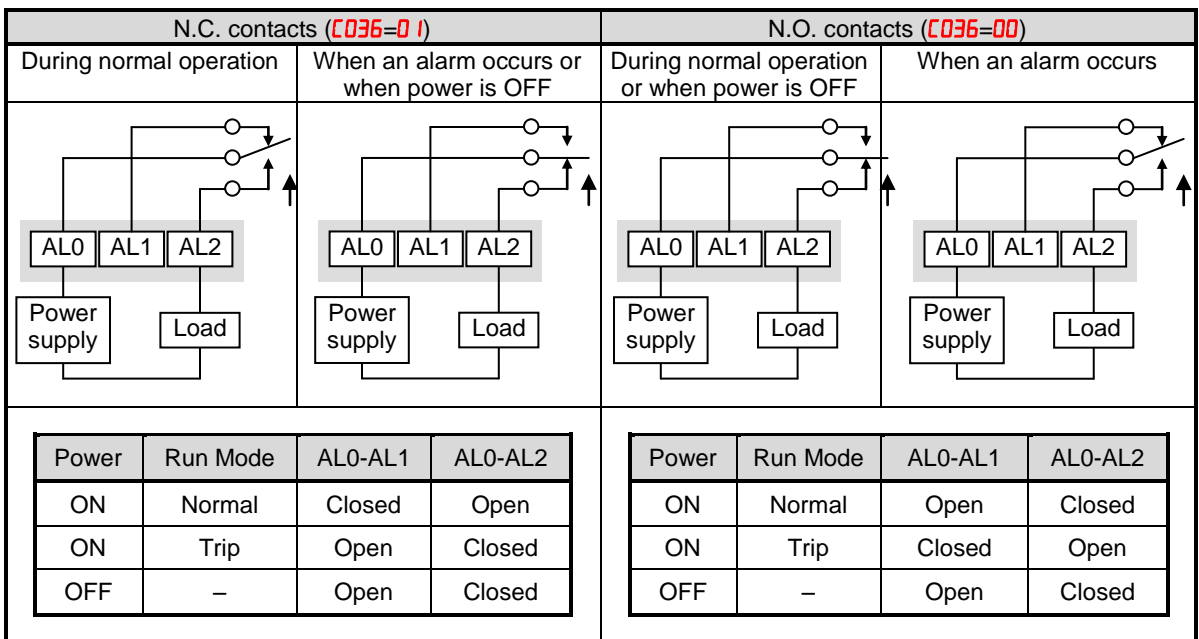

Analog Input Operation

The WL200 inverters provide for analog input to command the inverter frequency output value. The analog input terminal group includes the [L], [OI], [O], and [H] terminals on the control connector, which provide for Voltage [O] or Current [OI] input. All analog input signals must use the analog ground [L].

If you use either the voltage or current analog input, you must select one of them using the logic input terminal function [AT] analog type. Refer to the table on next page showing the activation of each analog input by combination of **ADD5** set parameter and [AT] terminal condition. The [AT] terminal function is covered in “Analog Input Current/Voltage Select” in section 4. Remember that you must also set **ADD1 = O1** to select analog input as the frequency source.

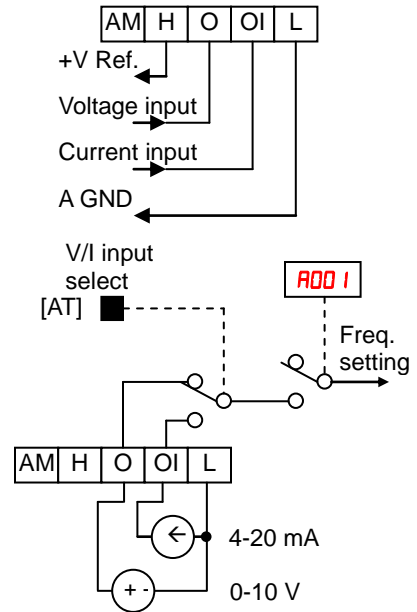

NOTE: If no logic input terminal is configured for the [AT] function, then inverter recognizes that [AT]=OFF and MCU recognizes [O]+[OI] as analog input.

Using an external potentiometer is a common way to control the inverter output frequency (and a good way to learn how to use the analog inputs). The potentiometer uses the built-in 10V reference [H] and the analog ground [L] for excitation, and the voltage input [O] for the signal. By default, the [AT] terminal selects the voltage input when it is OFF. Take care to use the proper resistance for the potentiometer, which is 1~2 k Ω , 2 Watts.

Voltage Input – The voltage input circuit uses terminals [L] and [O]. Attach the signal cable’s shield wire only to terminal [L] on the inverter. Maintain the voltage within specifications (do not apply negative voltage).

Current Input – The current input circuit uses terminals [OI] and [L]. The current comes from a *sourcing* type transmitter; a *sinking* type will not work! This means the current must flow into terminal [OI], and terminal [L] is the return back to the transmitter. The input impedance from [OI] to [L] is 100 Ohms. Attach the cable shield wire only to terminal [L] on the inverter.

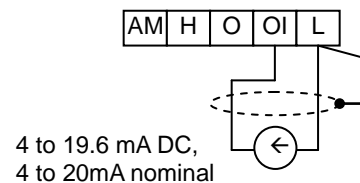
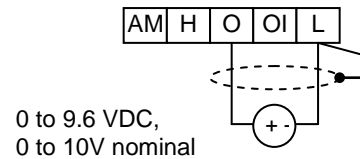
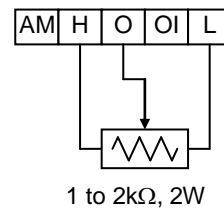

See I/O specs on page 23, 24.

The following table shows the available analog input settings. Parameter **A005** and the input terminal [AT] determine the External Frequency Command input terminals that are available, and how they function. The analog inputs [O] and [OI] use terminal [L] as the reference (signal return).

A005	[AT] Input	Analog Input Configuration
00	ON	[O]
	OFF	[O]
02	ON	Integrated POT on external panel
	OFF	[O]
03	ON	Integrated POT on external panel
	OFF	[OI]

Other Analog Input-related topics:

- “Analog Input Settings”
- “Additional Analog Input Settings”
- “Analog Signal Calibration Settings”
- “Analog Input Current/Voltage Select”
- “ADD Frequency Enable”
- “Analog Input Disconnect Detect”

Analog Output Operation

In inverter applications it is useful to monitor the inverter operation from a remote location or from the front panel of an inverter enclosure. In some cases, this requires only a panel-mounted volt meter. In other cases, a controller such as a PLC may provide the inverter's frequency command, and require inverter feedback data (such as output frequency or output current) to confirm actual operation. The analog output terminal [AM] serves these purposes.

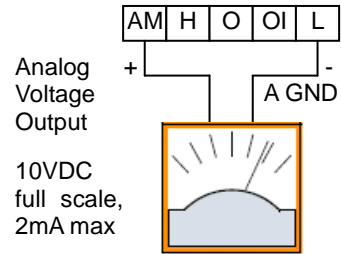

See I/O specs on page 23, 24

The inverter provides an analog voltage output on terminal [AM] with terminal [L] as analog GND reference. The [AM] can output inverter frequency or current output value. Note that the voltage range is 0 to +10V (positive-going only), regardless of forward or reverse motor rotation. Use **C028** to configure terminal [AM] as indicated below.

Func.	Code	Description
C028	00	Inverter output frequency
	01	Inverter output current
	02	Inverter output torque
	03	Digital output frequency
	04	Inverter output voltage
	05	Inverter input power
	06	Electronic Thermal Load
	07	LAD frequency
	08	Digital current monitor
	10	Cooling fin temperature
	12	General purpose
	16	Option

The [AM] signal offset and gain are adjustable, as indicated below.

Func.	Description	Range	Default
C 106	[AM] output gain	0~255.	100.
C 109	[AM] output offset	0.0~10.0	0.0

The graph below shows the effect of the gain and offset setting. To calibrate the [AM] output for your application (analog meter), follow the steps below:

1. Run the motor at the full scale speed.
 - a. If the analog meter represents output frequency, adjust offset (**C 109**) first, and then use **C 106** to set the voltage for full scale output.
 - b. If [AM] represents motor current, adjust offset (**C 109**) first, and then use **C 106** to set the voltage for full scale output. Remember to leave room at the upper end of the range for increased current when the motor is under heavier loads.

AM output offset adjustment

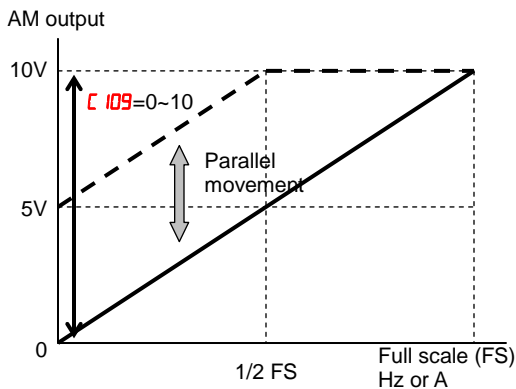

AM output gain adjustment

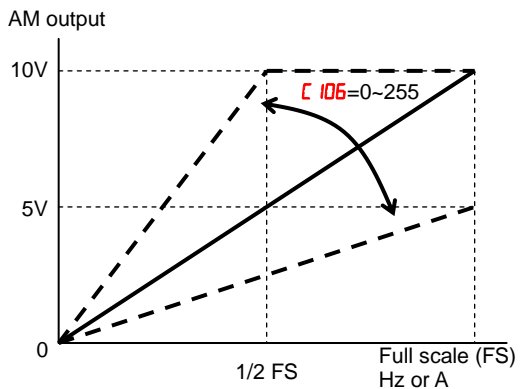

NOTE: As mentioned above, first adjust the offset, and then adjust the gain. Otherwise the required performance cannot be obtained because of the parallel movement of the offset adjustment.

Drive Parameter Setting Tables

Monitoring functions



NOTE: Parameters marked with "✓" in A column are accessible even in inverter running. Parameters marked with "✓" in B column are accessible even in inverter running when in the high level access mode, which means that b031 is set to "10".

* Please change from "04 (Basic display)" to "00 (Full display)" in parameter b037 (Function code display restriction), in case some parameters cannot be displayed.

IMPORTANT

Please be sure to set the motor nameplate data into the appropriate parameters

to ensure proper operation and protection of the motor:

- b012 is the motor overload protection value
- A082 is the motor voltage selection
- H003 is the motor kW capacity
- H004 is the number of motor poles

Please refer to the appropriate pages in this guide and the Instruction Manual for further details.

"d" Function			A	B	Units
Func. Code	Name	Description			
d001	Output frequency monitor	Real time display of output frequency to motor from 0.00 to 400.0Hz If b163 is set high, output frequency (F001) can be changed by up/down key with d001 monitoring.	✓	✓	Hz
d002	Output current monitor	Filtered display of output current to motor, range is 0.0 to 655.3 Ampere	-	-	A
d003	Rotation direction monitor	Three different indications: "F"...Forward "□"...Stop "r"...Reverse	-	-	-
d004	Process variable (PV), PID feedback monitor	Displays the scaled PID process variable (feedback) value (A075 is scale factor), 0.00 to 9999.00	-	-	% times constant
d005	Intelligent input terminal status	Displays the state of the intelligent input terminals: Terminal numbers	-	-	-

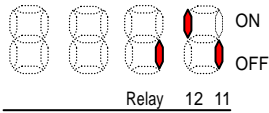
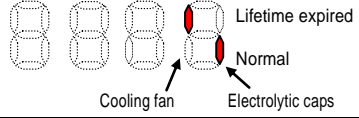
"d" Function			A	B	Units
Func. Code	Name	Description			
d006	Intelligent output terminal status	Displays the state of the intelligent output terminals: 	-	-	-
d007	Scaled output frequency monitor	Displays the output frequency scaled by the constant in b006 . Decimal point indicates range: 0 to 3999	✓	✓	Hz times constant
d013	Output voltage monitor	Voltage of output to motor, Range is 0.0 to 600.0V	-	-	V
d014	Input power monitor	Displays the input power, range is 0.0 to 999.9 Kw	-	-	KW
d015	Watt-hour monitor	Displays watt-hour of the inverter, range is 0 to 9999000	-	-	
d016	Elapsed RUN time monitor	Displays total time the inverter has been powered up in hours. Range is 0. to 9999. /	-	-	hours
d017	Elapsed power-on time monitor	1000 to 9999(10000 to 99990) / ┌100 to ┌999 (100000 to 999000)	-	-	hours
d018	Heat sink temperature monitor	Temperature of the cooling fin, range is -20 to 150	-	-	°C
d022	Life check monitor	Displays the state of lifetime of electrolytic capacitors on the PWB and cooling fan. 	-	-	-
d023	Program counter monitor [EzSQ]	Range is 0 to 1024	-	-	-
d024	Program number monitor [EzSQ]	Range is 0 to 9999	-	-	-
d025	User monitor 0 [EzSQ]	Result of EzSQ execution, range is -2147483647 to 2147483647	-	-	-
d026	User monitor 1 [EzSQ]	Result of EzSQ execution, range is -2147483647 to 2147483647	-	-	-
d027	User monitor 2 [EzSQ]	Result of EzSQ execution, range is -2147483647 to 2147483647	-	-	-
d050	Dual monitor	Displays two different data configured in b160 and b161 .	-	-	-

"d" Function			A	B	Units
Func. Code	Name	Description			
d062	Frequency source monitor	Displays the frequency source 0...Operator 1 to 15...Multi-speed freq. 1 to 15 16...Jog frequency 18...Modbus network 19...Option 21...Potentiometer 23...Calculate function output 24...EzSQ 25...[O] input 26...[OI] input 27...[O] + [OI]	-	-	-
d063	Run command source monitor	1...Control terminal 2...Operator 3...Modbus network 4...Option	-	-	-
d080	Trip counter	Number of trip events, Range is 0. to 65530	-	-	events
d081	Trip monitor 1	Displays trip event information: • Error code • Output frequency at trip point • Motor current at trip point • DC bus voltage at trip point • Cumulative inverter operation time at trip point • Cumulative power-ON time at trip point	-	-	-
d082	Trip monitor 2		-	-	-
d083	Trip monitor 3		-	-	-
d084	Trip monitor 4		-	-	-
d085	Trip monitor 5		-	-	-
d086	Trip monitor 6		-	-	-
d090	Warning monitor	Displays the warning code	-	-	-
d102	DC bus voltage monitor	Voltage of inverter internal DC bus, Range is 0.0 to 999.9 V	-	-	V
d103	BRD load ratio monitor	Usage ratio of integrated brake chopper, range is 0.0 to 100.0%	-	-	%
d104	Electronic thermal monitor	Accumulated value of electronic thermal detection, range is from 0.0 to 100.0%	-	-	%
d130	Analog input O monitor	Range is 0 to 1023	-	-	-
d131	Analog input OI monitor	Range is 0 to 1023	-	-	-
d153	PID deviation monitor	-9999.00 to 9999.00	-	-	% times Constant
d155	PID output monitor	Displays PID output, range is -100.00.to 100.00 %	-	-	%

Main Profile Parameters



NOTE: Parameters marked with "✓" in A column are accessible even in inverter running. Parameters marked with "✓" in B column are accessible even in inverter running when in the high level access mode, which means that b031 is set to "10".

"F" Function			A	B	Defaults	
Func. Code	Name	Description			Initial data	Units
F001	Output frequency setting	Standard default target frequency that determines constant motor speed, range is 0.0 / start frequency to maximum frequency (A004)	✓	✓	0.00	Hz
F002	Acceleration time (1)	Standard default acceleration, range is 0.00 to 3600 sec.	✓	✓	10.00	s
F202	Acceleration time (1), 2 nd motor		✓	✓	10.00	s
F003	Deceleration time (1)	Standard default deceleration, range is 0.00 to 3600 sec.	✓	✓	10.00	s
F203	Deceleration time (1), 2 nd motor		✓	✓	10.00	s
F004	Keypad RUN key routing	Two options; select codes: 00...Forward 01...Reverse	✗	✗	00	–

Standard Functions



NOTE: Parameters marked with "✓" in A column are accessible even in inverter running. Parameters marked with "✓" in B column are accessible even in inverter running when in the high level access mode, which means that b031 is set to "10".

"A" Function			A	B	Defaults	
Func. Code	Name	Description			Initial data	Units
R001	Frequency source	Eight options; select codes: 00...POT on ext. operator *Valid when connecting the OPE-SR/SRmini	✗	✗	01	–
R201	Frequency source, 2 nd motor	01...Control terminal *Set to "01" when connecting the WJ-VL or External volume via control terminal 02...Function F001 setting 03...Modbus network input 04...Option 07...via EzSQ 10...Calculate function output	✗	✗	01	–
R002	Run command source	Four options; select codes: 01...Control terminal	✗	✗	01	–
R202	Run command source, 2 nd motor	02...Run key on keypad, or digital operator 03...Modbus network input 04...Option	✗	✗	01	–
R003	Base frequency	Settable from 30 Hz to the maximum frequency(R004)	✗	✗	50.0	Hz
R203	Base frequency, 2 nd motor	Settable from 30 Hz to the 2 nd maximum frequency(R204)	✗	✗	50.0	Hz
R004	Maximum frequency	Settable from the base frequency to 400 Hz	✗	✗	50.0	Hz
R204	Maximum frequency, 2 nd motor	Settable from the 2 nd base frequency to 400 Hz	✗	✗	50.0	Hz
R005	[AT] selection	Three options; select codes: 00...Select between [O] and [OI] at [AT] (ON=OI, OFF=O) 02...Select between [O] and external POT at [AT] (ON=POT, OFF=O) 03...Select between [OI] and external POT at [AT] (ON=POT, OFF=OI)	✗	✗	00	–
RD11	[O] input active range start frequency	The output frequency corresponding to the analog input range starting point, range is 0.00 to 400.0 Hz	✗	✓	0.00	Hz
RD12	[O] input active range end frequency	The output frequency corresponding to the analog input range ending point, range is 0.00 to 400.0 Hz	✗	✓	0.00	Hz

"A" Function			A	B	Defaults	
Func. Code	Name	Description			Initial data	Units
AD13	[O] input active range start voltage	The starting point (offset) for the active analog input range, range is 0. to 100 %.	✗	✓	0.	%
AD14	[O] input active range end voltage	The ending point (offset) for the active analog input range, range is 0. to 100.%	✗	✓	100.	%
AD15	[O] input start frequency enable	Two options; select codes: 00...Use offset (AD11 value) 01...Use 0 Hz	✗	✓	01	-
AD16	Analog input filter	Range n = 1 to 31, 1 to 30 : × 2ms filter 31: 500ms fixed filter with ± 0.1 kHz hysteresis.	✗	✓	8.	Spl.
AD17	EzSQ function select	Select codes: 00...Disable 01...Activate by PRG terminal 02...Activate always	✓	✓	00	-
AD19	Multi-speed operation selection	Select codes: 00...Binary operation (16 speeds selectable with 4 terminals) 01...Bit operation (8 speeds selectable with 7 terminals)	✗	✗	00	-
AD20	Multi-speed freq. 0	Defines the first speed of a multi-speed profile, range is 0.00 / start frequency to 400 Hz	✓	✓	6.0	Hz
AD20	Multi-speed freq. 0, 2 nd motor	Defines the first speed of a multi-speed profile or a 2nd motor, range is 0.00 / start frequency to 400 Hz	✓	✓	6.0	Hz
AD21 to AD35	Multi-speed freq. 1 to 15 (for both motors)	Defines 15 more speeds, range is 0.00 / start frequency to 400 Hz. AD21=Speed 1 to AD35=Speed15	✓	✓	0.0	Hz
AD38	Jog frequency	Defines limited speed for jog, range is from start frequency to 9.99 Hz	✓	✓	6.00	Hz
AD39	Jog stop mode	Define how end of jog stops the motor; six options: 00...Free-run stop (invalid during run) 01...Controlled deceleration (invalid during run) 02...DC braking to stop(invalid during run) 03...Free-run stop (valid during run) 04...Controlled deceleration (valid during run) 05...DC braking to stop(valid during run)	✗	✓	04	-

"A" Function			A	B	Defaults	
Func. Code	Name	Description			Initial data	Units
R041	Torque boost select	Two options: 00...Manual torque boost 01...Automatic torque boost	✗	✗	00	–
R241	Torque boost select, 2 nd motor		✗	✗	00	–
R042	Manual torque boost value	Can boost starting torque between 0 and 20% above normal V/f curve, range is 0.0 to 20.0 %	✓	✓	1.0	%
R242	Manual torque boost value, 2 nd motor		✓	✓	1.0	%
R043	Manual torque boost frequency	Sets the frequency of the V/f breakpoint A in graph (top of previous page) for torque boost, range is 0.0 to 50.0 %	✓	✓	5.0	%
R243	Manual torque boost frequency, 2 nd motor		✓	✓	5.0	%
R044	V/f characteristic curve	Four available V/f curves; 00...Constant torque 01...Reduced torque (1.7) 02...Free V/F	✗	✗	00	–
R244	V/f characteristic curve, 2 nd motor		✗	✗	00	–
R045	V/f gain	Sets voltage gain of the inverter, range is 20. to 100.%	✓	✓	100.	%
R245	V/f gain, 2 nd motor		✓	✓	100.	%
R046	Voltage compensation gain for automatic torque boost	Sets voltage compensation gain under automatic torque boost, range is 0. to 255.	✓	✓	100.	–
R246	Voltage compensation gain for automatic torque boost, 2 nd motor		✓	✓	100.	–
R047	Slip compensation gain for automatic torque boost	Sets slip compensation gain under automatic torque boost, range is 0. to 255.	✓	✓	100.	–
R247	Slip compensation gain for automatic torque boost, 2 nd motor		✓	✓	100.	–
R051	DC braking enable	Three options; select codes: 00...Disable 01...Enable during stop 02...Frequency detection	✗	✓	00	–
R052	DC braking frequency	The frequency at which DC braking begins, Range is from the start frequency (b002) to 60Hz	✗	✓	0.5	Hz
R053	DC braking wait time	The delay from the end of controlled deceleration to start of DC braking (motor free runs until DC braking begins), range is 0.0 to 5.0 sec.	✗	✓	0.0	s
R054	DC braking force for deceleration	Level of DC braking force, settable from 0 to 100%	✗	✓	50.	%

"A" Function			A	B	Defaults	
Func. Code	Name	Description			Initial data	Units
R055	DC braking time for deceleration	Sets the duration for DC braking, range is from 0.0 to 60.0 seconds	✗	✓	0.5	s
R056	DC braking / edge or level detection for [DB] input	Two options; select codes: 00...Edge detection 01...Level detection	✗	✓	01	-
R057	DC braking force at start	Level of DC braking force at start, settable from 0 to 70 %	✗	✓	0.	%
R058	DC braking time at start	Sets the duration for DC braking, range is from 0.0 to 60.0 seconds	✗	✓	0.0	s
R059	Carrier frequency during DC braking	Carrier frequency of DC braking performance, range is from 2.0 to 10.0kHz	✗	✓	2.0	kHz
R061	Frequency upper limit	Sets a limit on output frequency less than the maximum frequency (R004-R0204). Range is from frequency lower limit (R062-R262) to maximum frequency (R004-R0204). 0.0 setting is disabled >0.0 setting is enabled	✗	✓	0.00	Hz
R261	Frequency upper limit, 2nd motor		✗	✓	0.00	Hz
R062	Frequency lower limit	Sets a limit on output frequency greater than zero. Range is start frequency (b082) to frequency upper limit (R061-R261) 0.0 setting is disabled >0.0 setting is enabled	✗	✓	0.00	Hz
R262	Frequency lower limit, 2nd motor		✗	✓	0.00	Hz
R063 R065 R067	Jump freq. (center) 1 to 3	Up to 3 output frequencies can be defined for the output to jump past to avoid motor resonances (center frequency) Range is 0.00 to 400.0 Hz	✗	✓	0.00	Hz
R064 R066 R068	Jump freq. width (hysteresis) 1 to 3	Defines the distance from the center frequency at which the jump around occurs Range is 0.00 to 10.0 Hz	✗	✓	0.50	Hz
R069	Acceleration hold frequency	Sets the frequency to hold acceleration, range is 0.0 to 400.0 ¹ Hz	✗	✓	0.00	Hz
R070	Acceleration hold time	Sets the duration of acceleration hold, range is 0.0 to 60.0 seconds	✗	✓	0.0	s
R071	PID enable	Enables PID function, three option codes: 00...PID Disable 01...PID Enable 02...PID Enable with reverse output	✗	✓	00	-
R072	PID proportional gain	Proportional gain has a range of 0.00 to 25.00	✓	✓	1.0	-

"A" Function			A	B	Defaults	
Func. Code	Name	Description			Initial data	Units
A073	PID integral time constant	Integral time constant has a range of 0.0 to 3600 seconds	✓	✓	1.0	s
A074	PID derivative time constant	Derivative time constant has a range of 0.00 to 100.0seconds seconds	✓	✓	0.00	s
A075	PV scale conversion	Process Variable (PV), scale factor (multiplier), range of 0.01 to 99.99	✗	✓	1.00	–
A076	PV source	Selects source of Process Variable (PV), option codes: 00...[OI] terminal (current in) 01...[O] terminal (voltage in) 02...Modbus network 10...Calculate function output	✗	✓	00	–
A077	Reverse PID action	Two option codes: 00...PID input = SP-PV 01...PID input = -(SP-PV)	✗	✓	00	–
A078	PID output limit	Sets the limit of PID output as percent of full scale, range is 0.0 to 100.0%	✗	✓	0.0	%
A079	PID feed forward selection	Selects source of feed forward gain, option codes: 00...Disabled 01...[O] terminal (voltage in) 02...[OI] terminal (current in)	✗	✓	00	–
A081	AVR function select	Automatic (output) voltage regulation, selects from three type of AVR functions, three option codes:	✗	✗	02	–
A281	AVR function select, 2 nd motor	00...AVR enabled 01...AVR disabled 02...AVR enabled except during deceleration	✗	✗	02	–
A082	AVR voltage select	200V class inverter settings:200/215/220/230/240	✗	✗	230/ 400	V
A282	AVR voltage select, 2 nd motor	400V class inverter settings:380/400/415/440/460/480	✗	✗	230/ 400	V
A083	AVR filter time constant	Define the time constant of the AVR filter, range is 0 to 10 sec.	✗	✓	0.300	s
A084	AVR deceleration gain	Gain adjustment of the braking performance, range is 50. to 200.%	✗	✓	100.	%
A085	Energy-saving operation mode	Two option codes: 00...Normal operation 01...Energy-saving operation	✗	✗	00	–
A086	Energy-saving mode tuning	Range is 0.0 to 100 %.	✓	✓	50.0	%
A092	Acceleration time (2)	Duration of 2 nd segment of acceleration, range is: 0.00 to 3600 sec.	✓	✓	10.00	s
A292	Acceleration time (2), 2 nd motor		✓	✓	10.00	s

"A" Function			A	B	Defaults	
Func. Code	Name	Description			Initial data	Units
A093	Deceleration time (2)	Duration of 2 nd segment of deceleration, range is: 0.00 to 3600 sec.	✓	✓	10.00	s
A293	Deceleration time (2), 2 nd motor		✓	✓	10.00	s
A094	Select method to switch to Acc2/Dec2 profile	Three options for switching from 1st to 2nd accel/decel: 00...2CH input from terminal 01...Transition frequency 02...Forward and reverse	✗	✗	00	–
A294	Select method to switch to Acc2/Dec2 profile, 2 nd motor		✗	✗	00	–
A095	Acc1 to Acc2 frequency transition point	Output frequency at which Accel1 switches to Accel2, range is 0.00 to 400.0 Hz	✗	✗	0.0	Hz
A295	Acc1 to Acc2 frequency transition point, 2 nd motor		✗	✗	0.0	Hz
A096	Dec1 to Dec2 frequency transition point	Output frequency at which Decel1 switches to Decel2, range is 0.00 to 400.0 Hz	✗	✗	0.0	Hz
A296	Dec1 to Dec2 frequency transition point, 2 nd motor		✗	✗	0.0	Hz
A097	Acceleration curve selection	Set the characteristic curve of Acc1 and Acc2, five options: 00...linear 01...S-curve 02...U-curve 03...Inverse U-curve	✗	✗	01	–
A098	Deceleration curve selection	Set the characteristic curve of Dec1 and Dec2, options are same as above (A097)	✗	✗	01	–
A101	[OI] input active range start frequency	The output frequency corresponding to the analog input range starting point, range is 0.00 to 400.0 Hz	✗	✓	0.00	Hz
A102	[OI] input active range end frequency	The output frequency corresponding to the current input range ending point, range is 0.00 to 400.0 Hz	✗	✓	0.00	Hz
A103	[OI] input active range start current	The starting point (offset) for the current input range, range is 0. to 100.%	✗	✓	20.	%
A104	[OI] input active range end current	The ending point (offset) for the current input range, range is 0. to 100.%	✗	✓	100.	%
A105	[OI] input start frequency select	Two options; select codes: 00...Use offset (A101 value) 01...Use 0Hz	✗	✓	00	–
A131	Acceleration curve constant	Range is 01 to 10.	✗	✓	2	–
A132	Deceleration curve constant	Range is 01 to 10.	✗	✓	2	–

"A" Function			A	B	Defaults	
Func. Code	Name	Description			Initial data	Units
A 141	A input select for calculate function	Six options: 00...Operator 01...POT on ext. Operator *Valid when connecting OPE-SR/SRmini	✗	✓	02	–
A 142	B input select for calculate function	02...Terminal [O] input 03...Terminal [OI] input 04...RS485 05...Option	✗	✓	03	–
A 143	Calculation symbol	Calculates a value based on the A input source (A 141 selects) and B input source (A 142 selects). Three options: 00...ADD (A input + B input) 01...SUB (A input - B input) 02...MUL (A input * B input)	✗	✓	00	–
A 145	ADD frequency	An offset value that is applied to the output frequency when the [ADD] terminal is ON. Range is 0.00 to 400 Hz	✗	✓	0.00	Hz
A 146	ADD direction select	Two options: 00...Plus (adds A 145 value to the output frequency setting) 01...Minus (subtracts A 145 value from the output frequency setting)	✗	✓	00	–
A 154	Deceleration hold frequency	Sets the frequency to hold deceleration, range is 0.00 to 400.0 Hz	✗	✓	0.0	Hz
A 155	Deceleration hold time	Sets the duration of deceleration hold, range is 0.0 to 60.0 seconds	✗	✓	0.0	s
A 156	PID sleep function action threshold	Sets the threshold for the action, set range 0.00 to 400.0 Hz	✗	✓	0.00	Hz
A 157	PID sleep function action delay time	Sets the delay time for the action, set range 0.0 to 25.5 sec	✗	✓	0.0	s
A 161	[VR] input active range start frequency	The output frequency corresponding to the analog input range starting point, range is 0.00 to 400.0 Hz	✗	✓	0.00	Hz
A 162	[VR] input active range end frequency	The output frequency corresponding to the current input range ending point, range is 0.00 to 400.0 Hz	✗	✓	0.00	Hz
A 163	[VR] input active range start %	The starting point (offset) for the current input range, range is 0. to 100.%	✗	✓	0.	%
A 164	[VR] input active range end %	The ending point (offset) for the current input range, range is 0. to 100 %	✗	✓	100.	%
A 165	[VR] input start frequency select	Two options; select codes: 00...Use offset (A 161 value) 01...Use 0Hz	✗	✓	01	–

Fine Tuning Functions

Func. Code	Name	"b" Function Description	A	B	Defaults	
					Initial data	Units
6001	Restart mode on power failure / under-voltage trip	Select inverter restart method, Five option codes: 00...Alarm output after trip, no automatic restart 01...Restart at 0Hz 02...Resume operation after frequency matching 03...Resume previous freq. after freq. matching, then decelerate to stop and display trip info 04...Resume operation after active freq. matching	✗	✓	00	–
6002	Allowable under-voltage power failure time	The amount of time a power input under-voltage can occur without tripping the power failure alarm. Range is 0.3 to 25 sec. If under-voltage exists longer than this time, the inverter trips, even if the restart mode is selected.	✗	✓	1.0	s
6003	Retry wait time before motor restart	Time delay after under-voltage condition goes away, before the inverter runs motor again. Range is 0.3 to 100 seconds.	✗	✓	1.0	s
6004	Instantaneous power failure / under-voltage trip alarm enable	Three option codes: 00...Disable 01...Enable 02...Disable during stop and decelerates to a stop	✗	✓	00	–
6005	Number of restarts on power failure / under-voltage trip events	Two option codes: 00...Restart 16 times 01...Always restart	✗	✓	00	–
6007	Restart frequency threshold	Restart the motor from 0Hz if the frequency becomes less than this set value during the motor is coasting, range is 0.00 to 400 Hz	✗	✓	0.00	Hz
6008	Restart mode on over voltage / over current trip	Select inverter restart method, Five option codes: 00...Alarm output after trip, no automatic restart 01...Restart at 0Hz 02...Resume operation after frequency matching 03...Resume previous freq. after active freq. matching, then decelerate to stop and display trip info 04...Resume operation after active freq. matching	✗	✓	00	–
6010	Number of retry on over voltage / over current trip	Range is 1 to 3 times	✗	✓	3	times
6011	Retry wait time on over voltage / over current trip	Range is 0.3 to 100 sec.	✗	✓	1.0	s

"b" Function			A	B	Defaults	
Func. Code	Name	Description			Initial data	Units
b0 12	Level of electronic thermal	Set a level between 20% and 100% of the rated inverter current.	✗	✓	Rated current for each inverter model	A
b2 12	Level of electronic thermal, 2 nd motor		✗	✓		A
b0 13	Electronic thermal characteristic	Select from three curves, option codes: 00...Reduced torque 01...Constant torque 02...Free setting	✗	✓	01	–
b2 13	Electronic thermal characteristic, 2 nd motor		✗	✓	01	–
b0 15	Free setting electronic thermal ~freq.1	Range is 0 to 400 Hz	✗	✓	0.0	Hz
b0 16	Free setting electronic thermal ~current1	Range is 0 to inverter rated current Amps	✗	✓	0.00	A
b0 17	Free setting electronic thermal ~freq.2	Range is 0 to 400 Hz	✗	✓	0.0	Hz
b0 18	Free setting electronic thermal ~current2	Range is 0 to inverter rated current Amps	✗	✓	0.00	A
b0 19	Free setting electronic thermal ~freq.3	Range is 0 to 400 Hz	✗	✓	0.0	Hz
b020	Free setting electronic thermal ~current3	Range is 0 to inverter rated current Amps	✗	✓	0.00	A
b02 1	Overload restriction operation mode	Select the operation mode during overload conditions, four options, option codes: 00...Disabled 01...Enabled for acceleration and constant speed 02...Enabled for constant speed only 03...Enabled for acceleration and constant speed, increase speed at regen.	✗	✓	01	–
b22 1	Overload restriction operation mode, 2 nd motor		✗	✓	01	–
b022	Overload restriction level	Sets the level of overload restriction, between 20 % and 150 % of the rated current of the inverter, setting resolution is 1 % of rated current	✗	✓	Rated current x 1.2	A
b222	Overload restriction level, 2 nd motor		✗	✓	Rated current x 1.2	A
b023	Deceleration rate at overload restriction	Sets the deceleration rate when inverter detects overload, range is 0.1 to 3000.0, resolution 0.1	✗	✓	1.0	s
b223	Deceleration rate at overload restriction, 2 nd motor		✗	✓	1.0	s

Func. Code	Name	"b" Function Description	A	B	Defaults	
					Initial data	Units
b024	Overload restriction operation mode 2	Select the operation mode during overload conditions, four options, option codes: 00 ...Disabled 01 ...Enabled for acceleration and constant speed 02 ...Enabled for constant speed only 03 ...Enabled for acceleration and constant speed, increase speed at regen.	✗	✓	01	–
b025	Overload restriction level 2	Sets the level of overload restriction, between 20 % and 150 % of the rated current of the inverter, setting resolution is 1 % of rated current	✗	✓	Rated current x 1.2	A
b026	Deceleration rate 2 at overload restriction	Sets the deceleration rate when inverter detects overload, range is 0.1 to 3000.0, resolution 0.1	✗	✓	1.0	s
b027	OC suppression selection	Two option codes: 00 ...Disabled 01 ...Enabled without voltage reduction 02 ...Enable with voltage reduction	✗	✓	00	–
b028	Current level of active freq. matching	Sets the current level of active freq. matching restart, range is 0.1*inverter rated current to 2.0*inverter rated current, resolution 0.1	✗	✓	Rated current	A
b029	Deceleration rate of active freq. matching	Sets the deceleration rate when active freq. matching restart, range is 0.1 to 3000.0, resolution 0.1	✗	✓	0.5	s
b030	Start freq. of active freq. matching	Three option codes: 00 ...freq at previous shutoff 01 ...start from max. Hz 02 ...start from set frequency	✗	✓	00	–
b031	Software lock mode selection	Prevents parameter changes, in five options, option codes: 00 ...all parameters except b031 are locked when [SFT] terminal is ON 01 ...all parameters except b031 and output frequency F001 are locked when [SFT] terminal is ON 02 ...all parameters except b031 are locked 03 ...all parameters except b031 and output frequency F001 are locked 10 ...High level access including b031 <i>See the row "Run Mode Edit" for the accessible parameters in this mode.</i>	✗	✓	01	–
b033	Motor cable length parameter	Set range is 5. to 20.	✓	✓	10.	–
b034	Run/power ON warning time	Range is, 0 .:Warning disabled 1 . to 9999 .: 10 - 99,990 hrs (unit: 10) 1000 to 6553 : 100,000 - 655,350 hrs (unit: 100)	✗	✓	0.	Hrs.
b035	Rotation direction restriction	Three option codes: 00 ...No restriction 01 ...Reverse rotation is restricted 02 ...Forward rotation is restricted	✗	✗	00	–

Func. Code	Name	"b" Function Description	A	B	Defaults	
					Initial data	Units
b036	Reduced voltage start selection	Set range, 0 (disabling the function), 1 (approx. 6ms) to 255 (approx. 1.5s)	✗	✓	2	-
b037	Function code display restriction	Six option codes: 00 ...Full display 01 ...Function-specific display 02 ...User setting (and b037) 03 ...Data comparison display 04 ...Basic display 05 ...Monitor display only	✗	✓	00	-
b038	Initial display selection	000 ...Initial display selection by SET key. 001 to 030 ... 001 to 030 displayed 201 ... F001 displayed 202 ...B display of LCD operator	✗	✓	001	-
b039	Automatic user parameter registration	Two option codes: 00 ...Disable 01 ...Enable	✗	✓	00	-
b050	Controlled deceleration on power loss	Four option codes: 00 ...Trips 01 ...Decelerates to a stop 02 ...Decelerates to a stop with DC bus voltage controlled 03 ...Decelerates to a stop with DC bus voltage controlled, then restart	✗	✗	00	-
b051	DC bus voltage trigger level of ctrl. decel.	Setting of DC bus voltage to start controlled decel. operation. Range is 0.0 to 1000.0	✗	✗	220.0/ 440.0	V
b052	Over-voltage threshold of ctrl. decel.	Setting the OV-LAD stop level of controlled decel. operation. Range is 0.0 to 1000.0	✗	✗	360.0/ 720.0	V
b053	Deceleration time of ctrl. decel.	Range is 0.01 to 3600.0	✗	✗	1.0	s
b054	Initial freq. drop of ctrl. decel.	Setting of initial freq. drop. Range is 0.00 to 10.0 Hz	✗	✗	0.0	Hz
b060	Maximum-limit level of window comparator (O)	Set range, {Min.-limit level (b061) + hysteresis width (b062)x2} to 100 % (Minimum of 0%)	✓	✓	100.	%
b061	Minimum-limit level of window comparator (O)	Set range, 0 to {Max.-limit level (b060) - hysteresis width (b062)x2} % (Maximum of 0%)	✓	✓	0.	%
b062	Hysteresis width of window comparator (O)	Set range, 0 to {Max.-limit level (b060) - Min.-limit level (b061)/2} % (Maximum of 10%)	✓	✓	0.	%
b063	Maximum-limit level of window comparator (OI)	Set range, {Min.-limit level (b064) + hysteresis width (b065)x2} to 100 % (Minimum of 0%)	✓	✓	100.	%
b064	Minimum-limit level of window comparator (OI)	Set range, 0 to {Max.-limit level (b063) - hysteresis width (b065)x2} % (Maximum of 0%)	✓	✓	0.	%
b065	Hysteresis width of window comparator (OI)	Set range, 0 to {Max.-limit level (b063) - Min.-limit level (b064)/2} % (Maximum of 10%)	✓	✓	0.	%
b070	Operation level at O disconnection	Set range, 0. to 100.%, or "no" (ignore)	✗	✓	no	-
b071	Operation level at OI disconnection	Set range, 0. to 100.%, or "no" (ignore)	✗	✓	no	-

Func. Code	Name	"b" Function Description	A	B	Defaults	
					Initial data	Units
b075	Ambient temperature setting	Set range is, -10 to 50 °C	✓	✓	40	°C
b078	Watt-hour clearance	Two option codes: 00...OFF 01...ON (press STR then clear)	✓	✓	00	-
b079	Watt-hour display gain	Set range is, 1. to 1000.	✓	✓	1.	-
b082	Start frequency	Sets the starting frequency for the inverter output, range is 0.10 to 9.99 Hz	✗	✓	0.50	Hz
b083	Carrier frequency	Sets the PWM carrier (internal switching frequency), range is 2.0 to 10.0 kHz	✗	✓	2.0	kHz
b084	Initialization mode (parameters or trip history)	Select initialized data, five option codes: 00...Initialization disabled 01...Clears Trip history 02...Initializes all Parameters 03...Clears Trip history and initializes all parameters 04...Clears Trip history and initializes all parameters and EzSQ program	✗	✗	00	-
b085	Country for initialization	01...Mode 1, 00...Mode 0, 03...Mode 3	✗	✗	01	-
b086	Frequency scaling conversion factor	Specify a constant to scale the displayed frequency for d007 monitor, range is 0.01 to 99.99	✓	✓	1.00	-
b087	STOP key enable	Select whether the STOP key on the keypad is enabled, three option codes: 00...Enabled 01...Disabled always 02... Disabled for stop	✗	✓	00	-
b088	Restart mode after FRS	Selects how the inverter resumes operation when free-run stop (FRS) is cancelled, three options: 00...Restart from 0Hz 01...Restart from frequency detected from real speed of motor (freq. matching) 02...Restart from frequency detected from real speed of motor (active freq. matching)	✗	✓	00	-
b089	Automatic carrier frequency reduction	Three option codes: 00...Disabled 01...Enabled, depending on the output current 02...Enabled, depending on the heat-sink temperature	✗	✗	01	-
b090	Dynamic braking usage ratio	Selects the rate of use (in %) of the regenerative braking resistor per 100 sec. intervals, range is 0.0 to the value calculated by the value of b097. If the connected resistor's allowable range is narrower than above range, the resistor's range is prior. 0%: Function disabled >0%: Enabled, per value	✗	✓	0.0	%
b091	Stop mode selection	Select how the inverter stops the motor, two option codes: 00...DEC (decelerate to stop) 01...FRS (free-run to stop)	✗	✓	00	-

Func. Code	Name	"b" Function Description	A	B	Defaults	
					Initial data	Units
b092	Cooling fan control (NOTE 1)	Selects when the fan is ON during inverter operation, three options: 00 ...Fan is always ON 01 ...Fan is ON during run, OFF during stop (5 minute delay from ON to OFF) 02 ...Fan is temperature controlled	✗	✓	01	-
b093	Clear elapsed time of cooling fan (NOTE 1)	Two option codes: 00 ...Count 01 ...Clear	✗	✗	00	-
b094	Initialization target data	Select initialized parameters, four option codes: 00 ...All parameters 01 ...All parameters except in/output terminals and communication. 02 ...Only registered parameters in U_{xxx} . 03 ...All parameters except registered parameters in U_{xxx} and b037 .	✗	✗	00	-
b095	Dynamic braking control (BRD) selection	Three option codes: 00 ...Disable 01 ...Enable during run only 02 ...Enable always	✗	✓	00	-
b096	BRD activation level	Range is: 330 to 380V (200V class) 660 to 760V (400V class)	✗	✓	360/ 720	V
b097	BRD resistor value	Set the value of the resistor connected to the inverter. By this setting, upper limit of $\square\square\square\square$ as the inverter hardware is calculated automatically. Range is minimum connectable resistor R_{bmin} to 600.0Ω	✗	✓	Min. Resistance	Ω
b 100	Free V/F setting, freq.1	Set range, 0 to value of b 102	✗	✗	0.	Hz
b 101	Free V/F setting, voltage.1	Set range, 0 to 800V	✗	✗	0.0	V
b 102	Free V/F setting, freq.2	Set range, value of b 100 to b 104	✗	✗	0.	Hz
b 103	Free V/F setting, voltage.2	Set range, 0 to 800V	✗	✗	0.0	V
b 104	Free V/F setting, freq.3	Set range, value of b 102 to b 106	✗	✗	0.	Hz
b 105	Free V/F setting, voltage.3	Set range, 0 to 800V	✗	✗	0.0	V
b 106	Free V/F setting, freq.4	Set range, value of b 104 to b 108	✗	✗	0.	Hz
b 107	Free V/F setting, voltage.4	Set range, 0 to 800V	✗	✗	0.0	V
b 108	Free V/F setting, freq.5	Set range, value of b 106 to b 110	✗	✗	0.	Hz
b 109	Free V/F setting, voltage.5	Set range, 0 to 800V	✗	✗	0.0	V
b 110	Free V/F setting, freq.6	Set range, value of b 108 to b 112	✗	✗	0.	Hz

Func. Code	Name	"b" Function Description	A	B	Defaults	
					Initial data	Units
b 111	Free V/F setting, voltage.6	Set range, 0 to 800V	✗	✗	0.0	V
b 112	Free V/F setting, freq.7	Set range, b 110 to 400(580) ^{*1}	✗	✗	0.	Hz
b 113	Free V/F setting, voltage.7	Set range, 0 to 800V	✗	✗	0.0	V
b 120	Brake control enable	Two option codes: 00...Disable 01...Enable/ 02... Enable (same as 01)	✗	✓	00	-
b 121	Brake Wait Time for Release	Set range: 0.00 to 5.00 sec	✗	✓	0.00	s
b 122	Brake Wait Time for Acceleration	Set range: 0.00 to 5.00 sec	✗	✓	0.00	s
b 123	Brake Wait Time for Stopping	Set range: 0.00 to 5.00 sec	✗	✓	0.00	s
b 124	Brake Wait Time for Confirmation	Set range: 0.00 to 5.00 sec	✗	✓	0.00	s
b 125	Brake release freq.	Set range: 0.00 to 400.0 ¹ Hz	✗	✓	0.00	Hz
b 126	Brake release current	Set range: 0.00 to 150 % of inverter rated current	✗	✓	Rated current	A
b 127	Braking freq. setting	Set range: 0.00 to 400.0 Hz	✗	✓	0.00	Hz
b 130	Deceleration overvoltage suppression enable	00...Disabled 01...Enabled 02...Enabled with accel.	✗	✓	00	-
b 131	Decel. overvolt. suppress level	DC bus voltage of suppression. Range is: 200V class...330 to 395 400V class...660 to 790	✗	✓	380 /760	V
b 132	Decel. overvolt. suppress const.	Accel. rate when b130=02. Set range: 0.10 to 30.00 sec.	✗	✓	1.00	s
b 133	Decel. overvolt. suppress proportional gain	Proportional gain when b130=01. Range is: 0.00 to 5.00	✓	✓	0.20	-
b 134	Decel. overvolt. suppress integral time	Integration time when b130=01. Range is: 0.0 to 150.0	✓	✓	1.0	s
b 145	GS input mode	Seven option codes: 00...No trip (Hardware shutoff only) 01...E37 trip 02...E98/E99 trip/ display -5--. With external fault detection 03...E99 trip/ display -5--. Without external fault detection 04...Display -5--. With external fault detection 05...Display input status. Without external fault detection 06...Display input status. With external fault detection	✗	✓	00	-
b 150	Display ex.operator connected	When an external operator is connected via RS-422 port, the built-in display is locked and shows only one "d" parameter configured in: d001 to d050	✓	✓	001	-

Func. Code	Name	"b" Function Description	A	B	Defaults	
					Initial data	Units
b 160	1st parameter of Dual Monitor	Set any two "d" parameters in b 160 and b 161, then they can be monitored in d050. The two parameters are switched by up/down keys. Set range: d001 ~ d027	✓	✓	001	-
b 161	2nd parameter of Dual Monitor		✓	✓	002	-
b 163	Frequency set in monitoring	Two option codes: 00...Freq. set disabled 01...Freq. set enabled	✓	✓	00	-
b 164	Automatic return to the initial display	10 min. after the last key operation, display returns to the initial parameter set by b038. Two option codes: 00...Disable 01...Enable	✓	✓	00	-
b 165	Ex. operator com. loss action	Five option codes: 00...Trip 01...Trip after deceleration to a stop 02...Ignore 03...Coasting (FRS) 04...Decelerates to a stop	✓	✓	02	-
b 166	Data Read/Write select	Two option codes: 00...Read/Write enable 01...both Read, Write disable	✗	✓	00	-
b 180	Initialization trigger	This is to perform initialization by parameter input with b084, b085 and b094. Two option codes: 00...Initialization disable 01...Perform initialization	✗	✗	00	-
b 190	Password Settings A	0000(Invalid Password) 0001-FFFF(Password)	✗	✗	0000	-
b 191	Password authentication A	0000-FFFF	✗	✗	0000	-
b 192	Password Settings B	0000(Invalid Password) 0001-FFFF(Password)	✗	✗	0000	-
b 193	Password authentication B	0000-FFFF	✗	✗	0000	-
b9 10	Electronic thermal subtraction function selection	Four option codes: 00...OFF 01...Linear subtraction: pre-fixed ratio 02...Linear subtraction: ratio set in b9 11 03...Subtraction with first-order lag filter: ratio set in b9 12	✗	✓	00	-
b9 11	Thermal subtraction time	This function is valid when b9 10=02 Range is 0.10 to 100000.00 s Out of warranty when setting less than initial value (600.00[s])	✗	✓	600.0	s
b9 12	Thermal subtraction time constant	This function is valid when b9 10=03 Range is 0.10 to 100000.00 s Out of warranty when setting less than initial value (120.00[s])	✗	✓	120.00	s
b9 13	Thermal accumulation gain	Range is 1.0 to 200.0 % Out of warranty when setting less than initial value (100.0[%])	✗	✓	100.0	%

(NOTE 1) Invalid for the models without cooling fan.

Intelligent Terminal Functions

"C" Function			A	B	Defaults	
Func. Code	Name	Description			Initial data	Units
C001	Input [1] function	Select input terminal [1] function, 56 options (see next section)	✗	✓	00 [FW]	–
C002	Input [2] function	Select input terminal [2] function, 56 options (see next section)	✗	✓	01 [RV]	–
C003	Input [3] function [GS1 assignable]	Select input terminal [3] function, 56 options (see next section)	✗	✓	12 [EXT]	–
C004	Input [4] function [GS2 assignable]	Select input terminal [4] function, 56 options (see next section)	✗	✓	18 [RS]	–
C005	Input [5] function [PTC assignable]	Select input terminal [5] function, 56 options (see next section)	✗	✓	02 [CF1]	–
C006	Input [6] function	Select input terminal [6] function, 56 options (see next section)	✗	✓	03 [CF2]	–
C007	Input [7] function	Select input terminal [7] function, 56 options (see next section)	✗	✓	06 [JG]	–
C011	Input [1] active state	Select logic conversion, two option codes: 00...normally open [NO] 01...normally closed [NC]	✗	✓	00	–
C012	Input [2] active state		✗	✓	00	–
C013	Input [3] active state		✗	✓	00	–
C014	Input [4] active state		✗	✓	00	–
C015	Input [5] active state		✗	✓	00	–
C016	Input [6] active state		✗	✓	00	–
C017	Input [7] active state		✗	✓	00	–
C021	Output [11] function [EDM assignable]	44 programmable functions available for logic (discrete) outputs (see next section)	✗	✓	00 [RUN]	–
C022	Output [12] function		✗	✓	01 [FA1]	–
C026	Alarm relay function		✗	✓	05 [AL]	–
C027	[EO] terminal selection (Pulse/PWM output)	11 programmable functions: 00...Output frequency (PWM) 01...Output current (PWM) 03...Output frequency (Pulse train) 04...Output voltage (PWM) 05...Input power (PWM) 06...Electronic thermal load ratio (PWM) 07...LAD frequency (PWM) 08...Output current (Pulse train) 10...Heat sink temperature (PWM) 12...General output (PWM) 16...Option(PWM)	✗	✓	07	–

"C" Function			A	B	Defaults	
Func. Code	Name	Description			Initial data	Units
C028	[AM] terminal selection (Analog voltage output 0...10V)	9 programmable functions: 00...Output frequency 01...Output current 04...Output voltage 05...Input power 06...Electronic thermal load ratio 07...LAD frequency 10...Heat sink temperature 13...General output 16...Option	X	✓	07 [LAD]	-
C030	Digital current monitor reference value	Current with digital current monitor output at 1,440Hz Range is 20 % to 150 % of rated current	✓	✓	Rated current	A
C031	Output [11] active state	Select logic conversion, two option codes: 00...normally open [NO] 01...normally closed [NC]	X	✓	00	-
C032	Output [12] active state		X	✓	00	-
C036	Alarm relay active state		X	✓	01	-
C038	Output mode of low current detection	Two option codes: 00...During acceleration, deceleration and constant speed 01...During constant speed only	X	✓	01	-
C039	Low current detection level	Set the level of low load detection, range is 0.0 to 1.5 * inverter rated current	✓	✓	Rated current	A
C040	Output mode of overload warning	Two option codes: 00...During accel., decel. and constant speed 01...During constant speed only	X	✓	01	-
C041	Overload warning level	Sets the overload warning signal level between 0% and 200% (from 0 to two time the rated current of the inverter)	✓	✓	Rated current x 1.15	A
C241	Overload warning level, 2 nd motor		✓	✓	Rated current x 1.15	A
C042	Frequency arrival setting for acceleration	Sets the frequency arrival setting threshold for the output frequency during acceleration, range is 0.0 to 400.0 Hz	X	✓	0.0	Hz
C043	Frequency arrival setting for deceleration	Sets the frequency arrival setting threshold for the output frequency during deceleration, range is 0.0 to 400.0 Hz	X	✓	0.0	Hz
C044	PID deviation level	Sets the allowable PID loop error magnitude (absolute value), SP-PV, range is 0.0 to 100 %	X	✓	3.0	%
C045	Frequency arrival setting 2 for acceleration	Set range is 0.0 to 400.0 Hz	X	✓	0.00	Hz
C046	Frequency arrival setting 2 for deceleration	Set range is 0.0 to 400.0 Hz	X	✓	0.00	Hz
C052	PID FBV output high limit	When the PV exceeds this value, the PID loop turns OFF the PID second stage output, range is 0.0 to 100 %	X	✓	100.0	%
C053	PID FBV output low limit	When the PV goes below this value, the PID loop turns ON the PID second stage output, range is 0.0 to 100 %	X	✓	0.0	%

"C" Function			A	B	Defaults	
Func. Code	Name	Description			Initial data	Units
C061	Electronic thermal warning level	Set range is 0 to 100% Setting 0 means disabled.	✗	✓	90.	%
C063	Zero speed detection level	Set range is 0.00 to 100.0Hz	✗	✓	0.00	Hz
C064	Heat sink overheat warning	Set range is 0. to 110. °C	✗	✓	100.	°C
C071	Communication speed	Eight option codes: 03...2,400 bps 04...4,800 bps 05...9,600 bps 06...19,200 bps 07...38,400 bps 08...57,600 bps 09...76,800 bps 10...115,200 bps	✗	✓	05	baud
C072	Modbus address	Set the address of the inverter on the network. Range is 1 to 247	✗	✓	1	–
C074	Communication parity	Three option codes: 00...No parity 01...Even parity 02...Odd parity	✗	✓	00	–
C075	Communication stop bit	Two option codes: 1...1 bit 2...2 bit	✗	✓	1	bit
C076	Communication error select	Selects inverter response to communications error. Five options: 00...Trip 01...Decelerate to a stop and trip 02...Disable 03...Free run stop (coasting) 04...Decelerates to a stop	✗	✓	02	–
C077	Communication error time-out	Sets the communications watchdog timer period. Range is 0.00 to 99.99 sec 0.0 = disabled	✗	✓	0.00	s
C078	Communication wait time	Time the inverter waits after receiving a message before it transmits. Range is 0. to 1000. ms	✗	✓	0.	ms
C081	O input span calibration	Scale factor between the external frequency command on terminals L–O (voltage input) and the frequency output, range is 0.0 to 200.0%	✓	✓	100.0	%
C082	O1 input span calibration	Scale factor between the external frequency command on terminals L–O1 (voltage input) and the frequency output, range is 0.0 to 200.0%	✓	✓	100.0	%
C085	Thermistor input (PTC) span calibration	Scale factor of PTC input. Range is 0.0 to 200.0%	✓	✓	100.0	%
C091	Debug mode enable	Displays debug parameters. Two option codes: 00...Disable 01...Enable <Do not set> (for factory use)	✓	✓	00	–
C096	Communication selection	00...Modbus-RTU 01... EzCOM 02... EzCOM<administrator>	✗	✗	00	–

"C" Function			A	B	Defaults	
Func. Code	Name	Description			Initial data	Units
C098	EzCOM start adr. of master	1 to 8	X	X	1.	–
C099	EzCOM end adr. of master	1 to 8	X	X	1.	–
C100	EzCOM starting trigger	00... Input terminal 01... Always	X	X	00	–
C101	Up/Down memory mode selection	Controls speed setpoint for the inverter after power cycle. Two option codes: 00...Clear last frequency (return to default frequency F00 I) 01...Keep last frequency adjusted by UP/DWN	X	✓	00	–
C102	Reset selection	Determines response to Reset input [RS]. Four option codes: 00...Cancel trip state at input signal ON transition, stops inverter if in Run Mode 01...Cancel trip state at signal OFF transition, stops inverter if in Run Mode 02...Cancel trip state at input ON transition, no effect if in Run Mode 03...Clear the memories only related to trip status	✓	✓	00	–
C103	Restart mode after reset	Determines the restart mode after reset is given, three option codes: 00...Start with 0 Hz 01...Start with freq. matching 02...Start with active freq. matching	X	✓	00	-
C104	UP/DWN clear mode	Freq. set value when UDC signal is given to the input terminal, two option codes: 00...0 Hz 01...Original setting (in the EEPROM memory at power on)	X	✓	00	-
C105	EO gain adjustment	Set range is 50. to 200.%	✓	✓	100.	%
C106	AM gain adjustment	Set range is 50. to 200.%	✓	✓	100.	%
C109	AM bias adjustment	Set range is 0. to 100.%	✓	✓	0.	%
C111	Overload warning level 2	Sets the overload warning signal 2 level between 0% and 200% (from 0 to two time the rated current of the inverter)	✓	✓	Rated current x 1.15	A
C130	Output [11] on delay	Set range is 0.0 to 100.0 sec.	X	✓	0.0	s
C131	Output [11] off delay		X	✓	0.0	s
C132	Output [12] on delay		X	✓	0.0	s
C133	Output [12] off delay		X	✓	0.0	s
C140	Relay output on delay		X	✓	0.0	s
C141	Relay output off delay		X	✓	0.0	s
C142	Logic output 1 operand A	All the programmable functions available for logic (discrete) outputs except LOG1 to LOG3, OPO, no	X	✓	00	–
C143	Logic output 1 operand B		X	✓	00	–

"C" Function			A	B	Defaults	
Func. Code	Name	Description			Initial data	Units
C 144	Logic output 1 operator	Applies a logic function to calculate [LOG] output state, Three options: 00...[LOG] = A AND B 01...[LOG] = A OR B 02...[LOG] = A XOR B	X	✓	00	–
C 145	Logic output 2 operand A	All the programmable functions available for logic (discrete) outputs except LOG1 to LOG3, OPO, no	X	✓	00	–
C 146	Logic output 2 operand B		X	✓	00	–
C 147	Logic output 2 operator	Applies a logic function to calculate [LOG] output state, Three options: 00...[LOG] = A AND B 01...[LOG] = A OR B 02...[LOG] = A XOR B	X	✓	00	–
C 148	Logic output 3 operand A	All the programmable functions available for logic (discrete) outputs except LOG1 to LOG3, OPO, no	X	✓	00	–
C 149	Logic output 3 operand B		X	✓	00	–
C 150	Logic output 3 operator	Applies a logic function to calculate [LOG] output state, Three options: 00...[LOG] = A AND B 01...[LOG] = A OR B 02...[LOG] = A XOR B	X	✓	00	–
C 160	Input [1] response time	Sets response time of each input terminal, set range is 0 (x 2 [ms]) to 200 (x 2 [ms]) for (0 to 400 [ms]).	X	✓	1.	–
C 161	Input [2] response time		X	✓	1.	–
C 162	Input [3] response time		X	✓	1.	–
C 163	Input [4] response time		X	✓	1.	–
C 164	Input [5] response time		X	✓	1.	–
C 165	Input [6] response time		X	✓	1.	–
C 166	Input [7] response time		X	✓	1.	–
C 169	Multistage speed/position determination time	Set range is 0. to 200. (x 10ms)	X	✓	0.	ms
C901	Overload warning processing cycle select	Two option codes: 00...40ms 01...2ms	X	✓	00	–
C902	Overload warning filter time constant	Set the filter time constant for output current detection used for judgement of overload warning. Range is 0 to 9999 ms	X	✓	0	ms
C903	Overload warning hysteresis	Set the hysteresis for overload warning signal. Range is 0 to 50% of the rated current of the inverter	X	✓	10.0	%

Input Function Summary Table – This table shows all thirty-one intelligent input functions at a glance. Detailed description of these functions, related parameters and settings, and example wiring diagrams are in “Using Intelligent Input Terminals” on page 29.

Input Function Summary Table				
Option Code	Terminal Symbol	Function Name	Description	
00	FW	FORWARD Run/Stop	ON	Inverter is in Run Mode, motor runs forward
			OFF	Inverter is in Stop Mode, motor stops
01	RV	Reverse Run/Stop	ON	Inverter is in Run Mode, motor runs reverse
			OFF	Inverter is in Stop Mode, motor stops
02	CF1	Multi-speed Select, Bit 0 (LSB)	ON	Binary encoded speed select, Bit 0, logical 1
			OFF	Binary encoded speed select, Bit 0, logical 0
03	CF2	Multi-speed Select, Bit 1	ON	Binary encoded speed select, Bit 1, logical 1
			OFF	Binary encoded speed select, Bit 1, logical 0
04	CF3	Multi-speed Select, Bit 2	ON	Binary encoded speed select, Bit 2, logical 1
			OFF	Binary encoded speed select, Bit 2, logical 0
05	CF4	Multi-speed Select, Bit 3 (MSB)	ON	Binary encoded speed select, Bit 3, logical 1
			OFF	Binary encoded speed select, Bit 3, logical 0
06	JG	Jogging	ON	Inverter is in Run Mode, output to motor runs at jog parameter frequency
			OFF	Inverter is in Stop Mode
07	DB	External DC braking	ON	DC braking will be applied during deceleration
			OFF	DC braking will not be applied
08	SET	Set (select) 2nd Motor Data	ON	The inverter uses 2nd motor parameters for generating frequency output to motor
			OFF	The inverter uses 1st (main) motor parameters for generating frequency output to motor
09	2CH	2-stage Acceleration and Deceleration	ON	Frequency output uses 2nd-stage acceleration and deceleration values
			OFF	Frequency output uses standard acceleration and deceleration values
11	FRS	Free-run Stop	ON	Causes output to turn OFF, allowing motor to free run (coast) to stop
			OFF	Output operates normally, so controlled deceleration stop motor
12	EXT	External Trip	ON	When assigned input transitions OFF to ON, inverter latches trip event and displays E 12
			OFF	No trip event for ON to OFF, any recorded trip events remain in history until reset
13	USP	Unattended Start Protection	ON	On powerup, the inverter will not resume a Run command (mostly used in the US)
			OFF	On powerup, the inverter will resume a Run command that was active before power loss
14	CS	Commercial power source switchover	ON	Motor can be driven by commercial power
			OFF	Motor is driven via the inverter
15	SFT	Software Lock	ON	The keypad and remote programming devices are prevented from changing parameters
			OFF	The parameters may be edited and stored
16	AT	Analog Input Voltage/Current Select	ON	Refer to “Analog Input Operation” on page 43.
			OFF	
18	RS	Reset Inverter	ON	The trip condition is reset, the motor output is turned OFF, and powerup reset is asserted
			OFF	Normal power-ON operation
19	PTC	PTC thermistor Thermal Protection (C005 only)	ANLG	When a thermistor is connected to terminal [5] and [L], the inverter checks for over-temperature and will cause trip event and turn OFF output to motor
			OPEN	A disconnect of the thermistor causes a trip event, and the inverter turns OFF the motor

Input Function Summary Table				
Option Code	Terminal Symbol	Function Name	Description	
20	STA	Start (3-wire interface)	ON	Starts the motor rotation
			OFF	No change to present motor status
21	STP	Stop (3-wire interface)	ON	Stops the motor rotation
			OFF	No change to present motor status
22	F/R	FWD, REV (3-wire interface)	ON	Selects the direction of motor rotation: ON = FWD. While the motor is rotating, a change of F/R will start a deceleration, followed by a change in direction
			OFF	Selects the direction of motor rotation: OFF = REV. While the motor is rotating, a change of F/R will start a deceleration, followed by a change in direction
23	PID	PID Disable	ON	Temporarily disables PID loop control. Inverter output turns OFF as long as PID Enable is active (A07 I=0 I)
			OFF	Has no effect on PID loop operation, which operates normally if PID Enable is active (A07 I=0 I)
24	PIDC	PID Reset	ON	Resets the PID loop controller. The main consequence is that the integrator sum is forced to zero
			OFF	No effect on PID controller
27	UP	Remote Control UP Function (motorized speed pot.)	ON	Accelerates (increases output frequency) motor from current frequency
			OFF	Output to motor operates normally
28	DWN	Remote Control Down Function (motorized speed pot.)	ON	Decelerates (decreases output frequency) motor from current frequency
			OFF	Output to motor operates normally
29	UDC	Remote Control Data Clearing	ON	Clears the UP/DWN frequency memory by forcing it to equal the set frequency parameter F001. Setting C 10 I must be set=00 to enable this function to work
			OFF	UP/DWN frequency memory is not changed
31	OPE	Operator Control	ON	Forces the source of the output frequency setting A00 I and the source of the Run command A002 to be from the digital operator
			OFF	Source of output frequency set by A00 I and source of Run command set by A002 is used
32	SF1	Multi-speed Select, Bit operation Bit 1	ON	Bit encoded speed select, Bit 1, logical 1
			OFF	Bit encoded speed select, Bit 1, logical 0
33	SF2	Multi-speed Select, Bit operation Bit 2	ON	Bit encoded speed select, Bit 2, logical 1
			OFF	Bit encoded speed select, Bit 2, logical 0
34	SF3	Multi-speed Select, Bit operation Bit 3	ON	Bit encoded speed select, Bit 3, logical 1
			OFF	Bit encoded speed select, Bit 3, logical 0
35	SF4	Multi-speed Select, Bit operation Bit 4	ON	Bit encoded speed select, Bit 4, logical 1
			OFF	Bit encoded speed select, Bit 4, logical 0
36	SF5	Multi-speed Select, Bit operation Bit 5	ON	Bit encoded speed select, Bit 5, logical 1
			OFF	Bit encoded speed select, Bit 5, logical 0
37	SF6	Multi-speed Select, Bit operation Bit 6	ON	Bit encoded speed select, Bit 6, logical 1
			OFF	Bit encoded speed select, Bit 6, logical 0
38	SF7	Multi-speed Select, Bit operation Bit 7	ON	Bit encoded speed select, Bit 7, logical 1
			OFF	Bit encoded speed select, Bit 7, logical 0
39	OLR	Overload Restriction Source Changeover	ON	Perform overload restriction
			OFF	Normal operation

Input Function Summary Table				
Option Code	Terminal Symbol	Function Name	Description	
44	BOK	Brake confirmation	ON	Brake wait time (b124) is valid
			OFF	Brake wait time (b124) is not valid
46	LAC	LAD cancellation	ON	Set ramp times are ignored. Inverter output immediately follows the freq. command.
			OFF	Accel. and/or decel. is according to the set ramp time
50	ADD	ADD frequency enable	ON	Adds the A145 (add frequency) value to the output frequency
			OFF	Does not add the A145 value to the output frequency
51	F-TM	Force Terminal Mode	ON	Force inverter to use input terminals for output frequency and Run command sources
			OFF	Source of output frequency set by A001 and source of Run command set by A002 is used
53	KHC	Clear watt-hour data	ON	Clear watt-hour data
			OFF	No action
56	MI1	General purpose input (1)	ON	General purpose input (1) is made ON under EzSQ
			OFF	General purpose input (1) is made OFF under EzSQ
57	MI2	General purpose input (2)	ON	General purpose input (2) is made ON under EzSQ
			OFF	General purpose input (2) is made OFF under EzSQ
58	MI3	General purpose input (3)	ON	General purpose input (3) is made ON under EzSQ
			OFF	General purpose input (3) is made OFF under EzSQ
59	MI4	General purpose input (4)	ON	General purpose input (4) is made ON under EzSQ
			OFF	General purpose input (4) is made OFF under EzSQ
60	MI5	General purpose input (5)	ON	General purpose input (5) is made ON under EzSQ
			OFF	General purpose input (5) is made OFF under EzSQ
61	MI6	General purpose input (6)	ON	General purpose input (6) is made ON under EzSQ
			OFF	General purpose input (6) is made OFF under EzSQ
62	MI7	General purpose input (7)	ON	General purpose input (7) is made ON under EzSQ
			OFF	General purpose input (7) is made OFF under EzSQ
65	AHD	Analog command hold	ON	Analog command is held
			OFF	Analog command is not held
77	GS1	GS1 input	ON	EN60204-1 related signals: Signal input of "Safe torque off" function.
			OFF	
78	GS2	GS2 input	ON	EN60204-1 related signals: Signal input of "Safe torque off" function.
			OFF	
81	485	Start EzCOM	ON	Starts EzCOM
			OFF	No execution
82	PRG	Executing EzSQ program	ON	Executing EzSQ program
			OFF	No execution
83	HLD	Retain output frequency	ON	Retain the current output frequency
			OFF	No retention
84	ROK	Permission of Run command	ON	Run command permitted
			OFF	Run command is not permitted
86	DISP	Display limitation	ON	Only a parameter configured in b038 is shown
			OFF	All the monitors can be shown
255	no	No function	ON	(input ignored)
			OFF	(input ignored)

Output Function Summary Table – This table shows all functions for the logical outputs (terminals [11], [12] and [AL]) at a glance. Detailed descriptions of these functions, related parameters and settings, and example wiring diagrams are in “Using Intelligent Output Terminals” on page 38.

Output Function Summary Table				
Option Code	Terminal Symbol	Function Name	Description	
00	RUN	Run Signal	ON	When the inverter is in Run Mode
			OFF	When the inverter is in Stop Mode
01	FA1	Frequency Arrival Type 1—Constant Speed	ON	When output to motor is at the set frequency
			OFF	When output to motor is OFF, or in any acceleration or deceleration ramp
02	FA2	Frequency Arrival Type 2—Over frequency	ON	When output to motor is at or above the set freq, even if in accel (C042) or decel (C043) ramps
			OFF	When output to motor is OFF, or at a level below the set frequency
03	OL	Overload Advance Notice Signal 1	ON	When output current is more than the set threshold (C041) for the overload signal
			OFF	When output current is less than the set threshold for the deviation signal
04	OD	Output Deviation for PID Control	ON	When PID error is more than the set threshold for the deviation signal
			OFF	When PID error is less than the set threshold for the deviation signal
05	AL	Alarm Signal	ON	When an alarm signal has occurred and has not been cleared
			OFF	When no alarm has occurred since the last cleaning of alarm(s)
06	FA3	Frequency Arrival Type 3—Set frequency	ON	When output to motor is at the set frequency, during accel (C042) and decel (C043).
			OFF	When output to motor is OFF, or is not at a level of the set frequency
09	UV	Undervoltage	ON	Inverter is in Undervoltage
			OFF	Inverter is not in Undervoltage
11	RNT	Run Time Expired	ON	Total running time of the inverter exceeds the specified value
			OFF	Total running time of the inverter does not exceed the specified value
12	ONT	Power ON time Expired	ON	Total power ON time of the inverter exceeds the specified value
			OFF	Total power ON time of the inverter does not exceed the specified value
13	THM	Thermal Warning	ON	Accumulated thermal count exceeds the C061 set value
			OFF	Accumulated thermal count does not exceed the C061 set value
19	BRK	Brake Release Signal	ON	Output for brake release
			OFF	No action for brake
20	BER	Brake Error Signal	ON	Brake error has occurred
			OFF	Brake performance is normal
21	ZS	Zero Hz Speed Detection Signal	ON	Output frequency falls below the threshold specified in C063
			OFF	Output frequency is higher than the threshold specified in C063
24	FA4	Frequency Arrival Type 4—Over frequency	ON	When output to motor is at or above the set freq., even if in accel (C045) or decel (C046) ramps
			OFF	When output to motor is OFF, or at a level below the set frequency

Output Function Summary Table

Option Code	Terminal Symbol	Function Name	Description	
25	FA5	Frequency Arrival Type 5-Set frequency	ON	When output to motor is at the set frequency, during accel (C045) and decel (C046).
			OFF	When output to motor is OFF, or is not at a level of the set frequency
26	OL2	Overload Advance Notice Signal 2	ON	When output current is more than the set threshold (C111) for the overload signal
			OFF	When output current is less than the set threshold for the deviation signal
27	ODc	Analog Voltage Input Disconnect Detection	ON	When the [O] input value < b070 setting (signal loss detected)
			OFF	When no signal loss is detected
28	OIDc	Analog Current input Disconnect Detection	ON	When the [OI] input value < b071 setting (signal loss detected)
			OFF	When no signal loss is detected
31	FBV	PID Second Stage Output	ON	Transitions to ON when the inverter is in RUN Mode and the PID Process Variable (PV) is less than the Feedback Low Limit (C053)
			OFF	Transitions to OFF when the PID Process Variable (PV) exceeds the PID High Limit (C052), and transitions to OFF when the inverter goes from Run Mode to Stop Mode
32	NDc	Network Disconnect Detection	ON	When the communications watchdog timer (period specified by C077) has time out
			OFF	When the communications watchdog timer is satisfied by regular communications activity
33	LOG1	Logic Output Function 1	ON	When the Boolean operation specified by C143 has a logical "1" result
			OFF	When the Boolean operation specified by C143 has a logical "0" result
34	LOG2	Logic Output Function 2	ON	When the Boolean operation specified by C146 has a logical "1" result
			OFF	When the Boolean operation specified by C146 has a logical "0" result
35	LOG3	Logic Output Function 3	ON	When the Boolean operation specified by C149 has a logical "1" result
			OFF	When the Boolean operation specified by C149 has a logical "0" result
39	WAC	Capacitor Life Warning Signal	ON	Lifetime of internal capacitor has expired.
			OFF	Lifetime of internal capacitor has not expired.
40	WAF	Cooling Fan Warning Signal	ON	Lifetime of cooling fan has expired.
			OFF	Lifetime of cooling fan has not expired.
41	FR	Starting Contact Signal	ON	Either FW or RV command is given to the inverter
			OFF	No FW or RV command is given to the inverter, or both are given to the inverter
42	OHF	Heat Sink Overheat Warning	ON	Temperature of the heat sink exceeds a specified value (C064)
			OFF	Temperature of the heat sink does not exceed a specified value (C064)
43	LOC	Low load detection	ON	Motor current is less than the specified value (C039)
			OFF	Motor current is not less than the specified value (C039)

Output Function Summary Table

Option Code	Terminal Symbol	Function Name	Description	
44	MO1	General Output 1	ON	General output 1 is ON
			OFF	General output 1 is OFF
45	MO2	General Output 2	ON	General output 2 is ON
			OFF	General output 2 is OFF
46	MO3	General Output 3	ON	General output 3 is ON
			OFF	General output 3 is OFF
50	IRDY	Inverter Ready Signal	ON	Inverter can receive a run command
			OFF	Inverter cannot receive a run command
51	FWR	Forward Rotation	ON	Inverter is driving the motor in forward direction
			OFF	Inverter is not driving the motor in forward direction
52	RVR	Reverse Rotation	ON	Inverter is driving the motor in reverse direction
			OFF	Inverter is not driving the motor in reverse direction
53	MJA	Major Failure Signal	ON	Inverter is tripping with major failure
			OFF	Inverter is normal, or is not tripping with major failure
54	WCO	Window Comparator for Analog Voltage Input	ON	Analog voltage input value is inside of the window comparator
			OFF	Analog voltage input value is outside of the window comparator
55	WCOI	Window Comparator for Analog Current Input	ON	Analog current input value is inside of the window comparator
			OFF	Analog current input value is outside of the window comparator
58	FREF	Frequency Command Source	ON	Frequency command is given from the operator
			OFF	Frequency command is not given from the operator
59	REF	Run Command Source	ON	Run command is given from the operator
			OFF	Run command is not given from the operator
60	SETM	2 nd Motor Selection	ON	2 nd motor is being selected
			OFF	2 nd motor is not being selected
62	EDM	STO (Safe Torque Off) Performance Monitor (Output terminal 11 only)	ON	STO is being performed
			OFF	STO is not being performed
63	OPO	Option card output	ON	(output terminal for option card)
			OFF	(output terminal for option card)
255	no	Not used	ON	-
			OFF	-

Motor Constants Functions

Func. Code	Name	Description	"H" Function		Defaults	
			A	B	Initial data	Units
H003	Motor capacity	Twelve selections: 0.1/0.2/0.4/0.75/1.5/2.2/3.7/5.5/7.5/11/15/18.5	✗	✗	Specified by the capacity of each inverter model	kW
H203	Motor capacity, 2 nd motor		✗	✗		
H004	Motor poles setting	Twenty four selections: 2/4/6/8/10/12/14/16/18/20/22/24/26/28/30/32/ 34/36/38/40/42/44/46/48	✗	✗	4	poles
H204	Motor poles setting, 2 nd motor		✗	✗	4	poles
H006	Motor stabilization constant	Motor constant (factory set), range is 0. to 255.	✓	✓	100.	-
H206	Motor stabilization constant, 2 nd motor		✓	✓	100.	-

Expansion Card Functions

"P" parameters will be appeared when the expansion option is connected.

Func. Code	Name	Description	"P" Function		Defaults	
			A	B	Initial data	Units
P001	Reaction when option card error occurs	Two option codes: 00...Inverter trips 01...Ignores the error (Inverter continues operation)	✗	✓	00	-
P031	Deceleration time Input Type	00...Operator 03...EzSQ	✗	✗	00	-
P044	Communication watchdog timer (for option)	Set range is 0.00 to 99.99s	✗	✗	1.00	s
P045	Inverter action on communication error (for option)	00...Tripping 01...Tripping after decelerating and stopping the motor 02...Ignoring errors 03...Stopping the motor after free-running 04...Decelerating and stopping the motor	✗	✗	00	-
P046	DeviceNet polled I/O: Output instance number	0 to 20	✗	✗	01	-
P048	Inverter action on communication idle mode	00...Tripping 01...Tripping after decelerating and stopping the motor 02...Ignoring errors 03...Stopping the motor after free-running 04...Decelerating and stopping the motor	✗	✗	00	-
P049	Motor poles setting for RPM	0/2/4/6/8/10/12/14/16/18/20/22/24/ 26/28/30/32/34/36/38/40/42/44/46/48	✗	✗	0	Poles

Func. Code	Name	"P" Function Description	A	B	Defaults	
					Initial data	Units
P 100 to P 131	EzSQ user parameter U(00) ~ U(31)	Each set range is 0 to 65535	✓	✓	0	-
P 140	EzCOM number of data	1 to 5	✓	✓	5	-
P 141	EzCOM destination 1 address	1 to 247	✓	✓	1	-
P 142	EzCOM destination 1 register	0000 to FFFF	✓	✓	0000	-
P 143	EzCOM source 1 register	0000 to FFFF	✓	✓	0000	-
P 144	EzCOM destination 2 address	1 to 247	✓	✓	2	-
P 145	EzCOM destination 2 register	0000 to FFFF	✓	✓	0000	-
P 146	EzCOM source 2 register	0000 to FFFF	✓	✓	0000	-
P 147	EzCOM destination 3 address	1 to 247	✓	✓	3	-
P 148	EzCOM destination 3 register	0000 to FFFF	✓	✓	0000	-
P 149	EzCOM source 3 register	0000 to FFFF	✓	✓	0000	-
P 150	EzCOM destination 4 address	1 to 247	✓	✓	4	-
P 151	EzCOM destination 4 register	0000 to FFFF	✓	✓	0000	-
P 152	EzCOM source 4 register	0000 to FFFF	✓	✓	0000	-
P 153	EzCOM destination 5 address	1 to 247	✓	✓	5	-
P 154	EzCOM destination 5 register	0000 to FFFF	✓	✓	0000	-
P 155	EzCOM source 5 register	0000 to FFFF	✓	✓	0000	-
P 160 to P 169	Option I/F command register to write 1 to 10	0000h to FFFFh	✓	✓	0000	-
P 170 to P 179	Option I/F command register to read 1 to 10	0000h to FFFFh	✓	✓	0000	-
P 180	Profibus Node address	0. to 125.	✗	✗	0.	-
P 181	Profibus Clear Node address	00...Clear 01...Hold previous time value	✗	✗	00	-
P 182	Profibus Map selection	00...PPO type 01...Conventional 02...Flexible Mode Format Selection	✗	✗	00	-
P 192	DeviceNet MAC ID	0 to 63	✗	✗	63	-

User setting parameters

Func. Code	Name	Description	"U" Function		Defaults	
			A	B	Initial data	Units
U001 to U032	User parameters 1 to 32	no/d001 to P196 Set range, "no", d001-P 183	✓	✓		-

Monitoring Trip Events, History, & Conditions

Trip History and Inverter Status

We recommend that you first find the cause of the fault before clearing it. When a fault occurs, the inverter stores the important performance data at the moment of the fault. To access the data, use the monitor function (dxxx) and select **d081** details about the present fault. The previous 5 faults are stored in **d082** to **d086**. When a fault occurs, each error log shifts **d081-d085** to **d082-d086**, and the latest error log is written in **d081**.

The following Monitor Menu map shows how to access the error logs. When fault(s) exist, you can review their details by first selecting the proper function: **d081** is the most recent, and **d086** is the oldest.

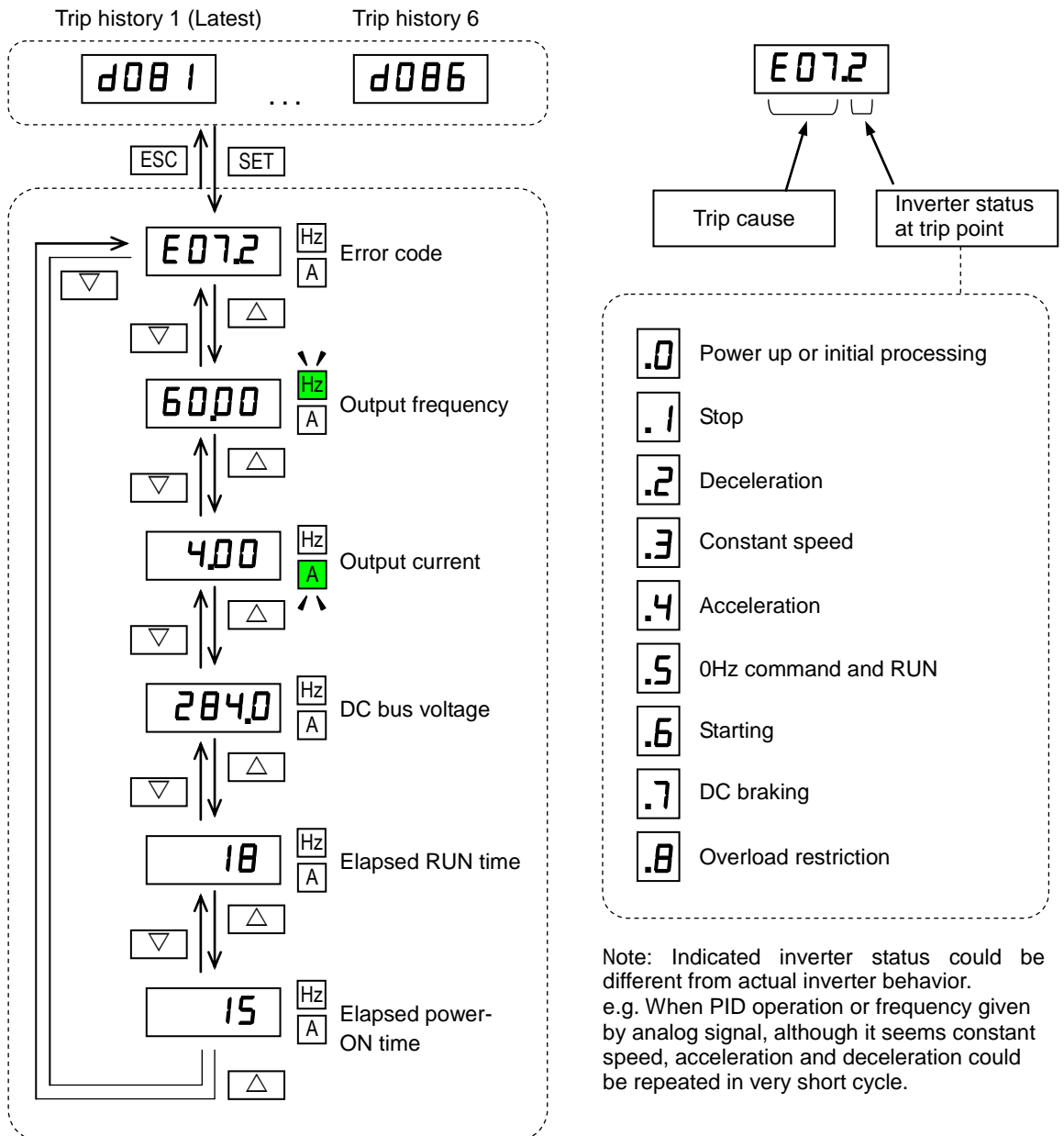

Error Codes

An error code will appear on the display automatically when a fault causes the inverter to trip. The following table lists the cause associated with the error.

Error Code	Name	Cause(s)
E01	Over-current event while at constant speed	The inverter output was short-circuited, or the motor shaft is locked or has a heavy load. These conditions cause excessive current for the inverter, so the inverter output is turned OFF. Setting in dual-voltage motor is wrong.
E02	Over-current event during deceleration	
E03	Over-current event during acceleration	
E04	Over-current event during other conditions	
E05	Overload protection	When a motor overload is detected by the electronic thermal function, the inverter trips and turns OFF its output.
E06	Braking resistor overload protection	When the BRD operation rate exceeds the setting of "b090", this protective function shuts off the inverter output and displays the error code.
E07	Over-voltage protection	When the DC bus voltage exceeds a threshold, due to such causes as regenerative energy from the motor or rise of power voltage, etc.
E08	EEPROM error	When the built-in EEPROM memory has problems due to noise or excessive temperature, the inverter trips and turns OFF its output to the motor.
E09	Under-voltage error	A decrease of internal DC bus voltage below a threshold results in a control circuit fault. This condition can also generate excessive motor heat or cause low torque. The inverter trips and turns OFF its output.
E10	Current detection error	If an error occurs in the internal current detection system, the inverter will shut off its output and display the error code.
E11	CPU error	A malfunction in the built-in CPU has occurred, so the inverter trips and turns OFF its output to the motor.
E12	External trip	A signal on an intelligent input terminal configured as EXT has occurred. The inverter trips and turns OFF the output to the motor.
E13	USP	When the Unattended Start Protection (USP) is enabled, an error occurred when power is applied while a Run signal is present. The inverter trips and does not go into Run Mode until the error is cleared.
E14	Ground fault	The inverter is protected by the detection of ground faults between the inverter output and the motor upon during powerup tests. This feature protects the inverter, and does not protect humans.
E15	Input over-voltage	The inverter tests for input over-voltage after the inverter has been in Stop Mode for 100 seconds. If an over-voltage condition exists, the inverter enters a fault state. After the fault is cleared, the inverter can enter Run Mode again.
E19	Inverter thermal detection system error	When the thermal sensor in the inverter module is not connected.
E21	Inverter thermal trip	When the inverter internal temperature is above the threshold, the thermal sensor in the inverter module detects the excessive temperature of the power devices and trips, turning the inverter output OFF.
E22	CPU communication error	When communication between two CPU fails, inverter trips and displays the error code.

Error Code	Name	Cause(s)
E25	Main circuit error	The inverter will trip if the power supply establishment is not recognized because of a malfunction due to noise or damage to the main circuit element.
E30	Driver error	An internal inverter error has occurred at the safety protection circuit between the CPU and main driver unit. Excessive electrical noise may be the cause. The inverter has turned OFF the IGBT module output.
E35	Thermistor	When a thermistor is connected to terminals [5] and [L] and the inverter has sensed the temperature is too high, the inverter trips and turns OFF the output.
E36	Braking error	When "01" has been specified for the Brake Control Enable (b120), the inverter will trip if it cannot receive the braking confirmation signal within the Brake Wait Time for Confirmation (b124) after the output of the brake release signal.
E37	Safe Stop	Safe stop signal is given when b145 =01.
E38	Low-speed overload protection	If overload occurs during the motor operation at a very low speed, the inverter will detect the overload and shut off the inverter output.
E40	Operator connection	When the connection between inverter and operator keypad failed, inverter trips and displays the error code.
E41	Modbus communication error	When "trip" is selected (C076=00) as a behavior in case of communication error, inverter trips when timeout happens.
E43	EzSQ invalid instruction	The program stored in inverter memory has been destroyed, or the PRG terminal was turned on without a program downloaded to the inverter.
E44	EzSQ nesting count error	Subroutines, if-statement, or for-next loop are nested in more than eight layers
E45	EzSQ instruction error	Inverter found the command which cannot be executed.
E50 to E59	EzSQ user trip (0 to 9)	When user –defined trip happens, inverter trips and displays the error code.
E60 to E69	Option error	The inverter detects errors in the option board mounted in the optional slot. For details, refer to the instruction manual for the mounted option board.











NOTE: Reset is not allowed in 10 second after trip.

NOTE: When error E08, E14 and E30 occur, reset operation by RS terminal or STOP/RESET key is not accepted. In this case, reset by cycling power. If still same error occurs, perform initialization.

NOTE: When error E37 occur, reset operation by STOP/RESET key is not accepted. In this case, reset by cycling power. If still same error occurs, perform initialization.

Other indication

Error Code	Name	Descriptions
 Rotating	Reset	RS input is ON or STOP/RESET key is pressed.
	Undervoltage	If input voltage is under the allowed level, inverter shuts off output and waits with this indication.
	Waiting to restart	This indication is displayed after tripping before restarting.
	Restricted operation command	Commanded RUN direction is restricted in b035.
	Trip history initializing	Trip history is being initialized.
	No data (Trip monitor)	No trip/waning data exists.
 Blinking	Communication error	Communication between inverter and digital operator fails.
	Auto-tuning completed	Auto-tuning is completed properly.
	Auto-tuning error	Auto-tuning fails.

For more details, please refer to troubleshooting of the Instruction Manual.

Restoring Factory Default Settings

You can restore all inverter parameters to the original factory (default) settings according to area of use. After initializing the inverter, use the powerup test (please refer to Chapter 2 in the Instruction Manual) to get the motor running again. If operation mode (std. or high frequency) mode is changed, inverter must be initialized to activate new mode. To initialize the inverter, follow the steps below.

- (1) Select initialization mode in **b084**.
- (2) If **b084=02, 03** or **04**, select initialization target data in **b094**.
- (3) If **b084=02, 03** or **04**, select country code in **b085**.
- (4) Set **01** in **b180**.
- (5) Initialization is started, and is completed with **d001** displayed.

* Please change from "04 (Basic display)" to "00 (Full display)" in parameter **b037** (Function code display restriction), in case some parameters cannot be displayed.

CE-EMC Installation Guidelines

You are required to satisfy the EMC directive (2004/108/EC) when using a WL200 inverter in an EU country.

To satisfy the EMC directive and to comply with standard, you need to use a dedicated EMC filter suitable for each model, and follow the guidelines in this section. Following table shows the compliance condition for reference.

Table 1. Condition for the compliance

Model	Cat.	Carrier f	Motor cable
All WL200 series	C1	2kHz	20m (Shielded)

Table 2. Applicable EMC filter

Input class	Inverter model	Filter model (Schaffner)
1-ph. 200V class	WL200-002SF	FS24828-8-07
	WL200-004SF	
	WL200-007SF	
	WL200-015SF	FS24828-27-07
	WL200-022SF	
3-ph. 400V class	WL200-004HF	FS24830-6-07
	WL200-007HF	
	WL200-015HF	
	WL200-022HF	FS24830-12-07
	WL200-030HF	
	WL200-040HF	FS24830-15-07
	WL200-055HF	
	WL200-075HF	FS24830-29-07
	WL200-110HF	
	WL200-150HF	FS24830-48-07
WL200-185HF		

WL200-185H needs to be installed in a metal cabinet and add ferrite core at the input cable to meet category C1. Unless otherwise category C2.

Important notes

1. Input choke or other equipment is required if necessary to comply with EMC directive from the harmonic distortion point of view (IEC 61000-3-2 and 4).
2. If the motor cable length exceeds 20m, use output choke to avoid unexpected problem due to the leakage current from the motor cable (such as malfunction of the thermal relay, vibration of the motor, etc...).
3. As user you must ensure that the HF (high frequency) impedance between adjustable frequency inverter, filter, and ground is as small as possible.
 - Ensure that the connections are metallic and have the largest possible contact areas (zinc-plated mounting plates).
4. Avoid conductor loops that act like antennas, especially loops that encompass large areas.
 - Avoid unnecessary conductor loops.
 - Avoid parallel arrangement of low-level signal wiring and power-carrying or noise-prone conductors.
5. Use shielded wiring for the motor cable and all analog and digital control lines.
 - Allow the effective shield area of these lines to remain as large as possible; i.e., do not strip away the shield (screen) further away from the cable end than absolutely necessary.

- With integrated systems (for example, when the adjustable frequency inverter is communicating with some type of supervisory controller or host computer in the same control cabinet and they are connected at the same protective ground), connect the shields of the control lines to protective ground at both ends. With distributed systems (for example the communicating supervisory controller or host computer is not in the same control cabinet and there is a distance between the systems), we recommend connecting the shield of the control lines only at the end connecting to the adjustable frequency inverter. If possible, route the other end of the control lines directly to the cable entry section of the supervisory controller or host computer. The shield conductor of the motor cables must always be connected to protective ground at both ends.
 - To achieve a large area contact between shield and protective ground, use a PG screw with a metallic shell, or use a metallic mounting clip.
 - Use only cable with braided, tinned copper mesh shield (type “CY”) with 85% coverage.
 - The shielding continuity should not be broken at any point in the cable. If the use of reactors, contactors, terminals, or safety switches in the motor output is necessary, the unshielded section should be kept as short as possible.
 - Some motors have a rubber gasket between terminal box and motor housing. Very often, the terminal boxes, and particularly the threads for the metal PG screw connections, are painted. Make sure there is always a good metallic connection between the shielding of the motor cable, the metal PG screw connection, the terminal box, and the motor housing. If necessary, carefully remove paint between conducting surfaces.
6. Take measures to minimize interference that is frequently coupled in through installation cables.
- Separate interfering cables with 0.25m minimum from cables susceptible to interference. A particularly critical point is laying parallel cables over longer distances. If two cables intersect (one crosses over the other), the interference is smallest if they intersect at an angle of 90°. Cables susceptible to interference should therefore only intersect motor cables, intermediate circuit cables, or the wiring of a rheostat at right angles and never be laid parallel to them over longer distances.
7. Minimize the distance between an interference source and an interference sink (interference- threatened device), thereby decreasing the effect of the emitted interference on the interference sink.
- You should use only interference-free devices and maintain a minimum distance of 0.25 m from the adjustable frequency inverter.
8. Follow safety measures in the filter installation.
- If using external EMC filter, ensure that the ground terminal (PE) of the filter is properly connected to the ground terminal of the adjustable frequency inverter. An HF ground connection via metal contact between the housings of the filter and the adjustable frequency inverter, or solely via cable shield, is not permitted as a protective conductor connection. The filter must be solidly and permanently connected with the ground potential so as to preclude the danger of electric shock upon touching the filter if a fault occurs.
- To achieve a protective ground connection for the filter:
- Ground the filter with a conductor of at least 10 mm² cross-sectional area.
 - Connect a second grounding conductor, using a separate grounding terminal parallel to the protective conductor. (The cross section of each single protective conductor terminal must be sized for the required nominal load.)

Installation for WL200 series (example of SF models)

HFx (3-ph. 400V class) Models are the same concept for the installation.

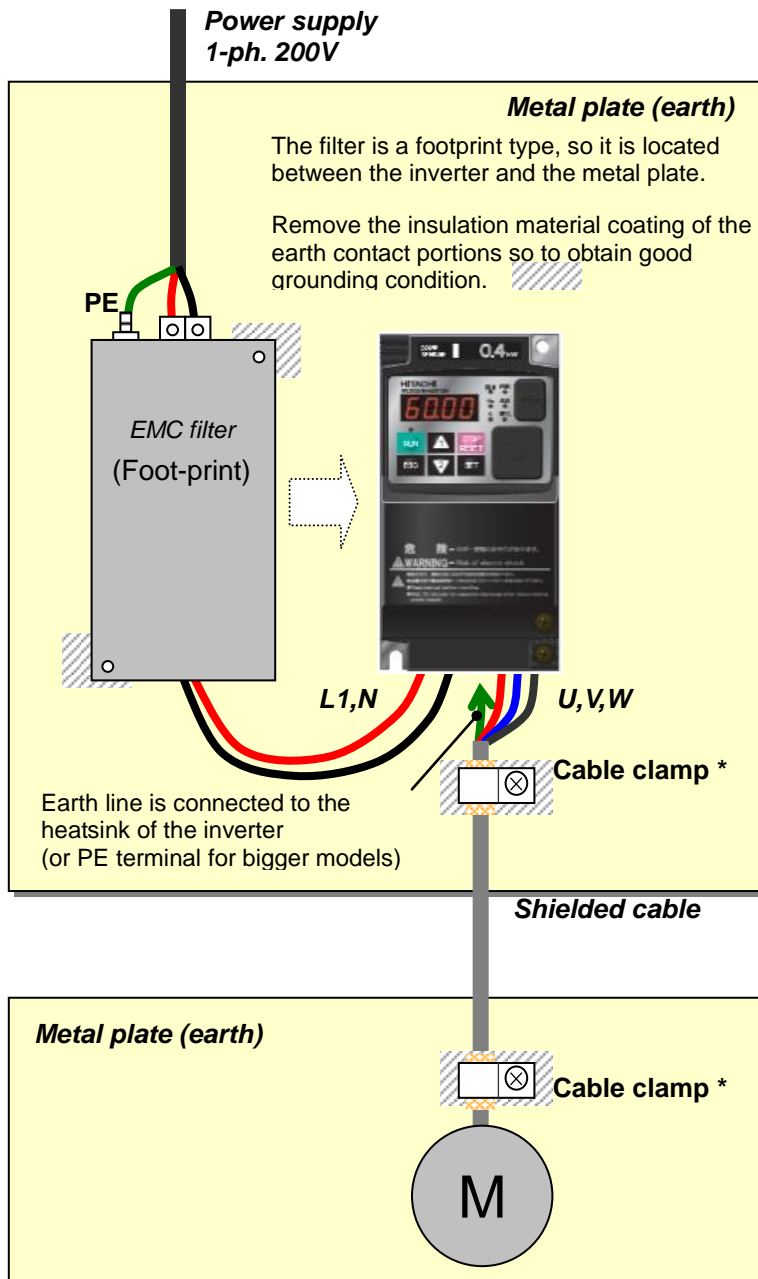

*) Both earth portions of the shielded cable must be connected to the earth point by cable clamps.

Input choke or equipment to reduce harmonic current is necessary for CE marking (IEC 61000-3-2 and IEC61000-3-3) from the harmonic current point of view, even conducted emission and radiated emission passed without the input choke.

Hitachi EMC Recommendations



WARNING: This equipment should be installed, adjusted, and serviced by qualified personnel familiar with construction and operation of the equipment and the hazards involved. Failure to observe this precaution could result in bodily injury.

Use the following checklist to ensure the inverter is within proper operating ranges and conditions.

1. The power supply to WL200 inverters must meet these specifications:
 - Voltage fluctuation $\pm 10\%$ or less
 - Voltage imbalance $\pm 3\%$ or less
 - Frequency variation $\pm 4\%$ or less
 - Voltage distortion THD = 10% or less
2. Installation measure:
 - Use a filter designed for WL200 inverter. Refer to the instruction of the applicable external EMC filter.
3. Wiring:
 - Shielded wire (screened cable) is required for motor wiring, and the length must be 20 meter or less.
 - If the motor cable length exceeds the value shown above, use output choke to avoid unexpected problem due to the leakage current from the motor cable.
 - The carrier frequency setting must be 2 kHz to satisfy EMC requirements.
 - Separate the power input and motor wiring from the signal/process circuit wiring.
4. Environmental conditions—when using a filter, follow these guidelines:
 - Ambient temperature: -10 to 40°C (Derating is required when the ambient temperature exceeds 40°C)
 - Humidity: 20 to 90% RH (non-condensing)
 - Vibration: 5.9 m/sec^2 (0.6 G) 10 ~ 55Hz
 - Location: 1000 meters or less altitude, indoors (no corrosive gas or dust)

Functional Safety (The certificate is in progress.)

Introduction

The Gate Suppress function can be utilized to perform a safe stop according to the EN60204-1, stop category 0 (Uncontrolled stop by power removal) (as STO function of IEC/EN61800-5-2). It is designed to meet the requirements of the ISO13849-1 Cat.3 PLd, IEC61508 SIL2 and IEC/EN61800-5-2 SIL2 only in a system in which EDM signal is monitored by an "External Device Monitor".

Stop Category defined in EN60204-1

Category 0 : Uncontrolled stop by immediate (< 200 ms) shut-down of the power supply to the actuators. (as STO function of IEC/EN61800-5-2)

Category 1 : Controlled stop by interrupting the power supply to the actuator level if, for example, the hazardous movement has been brought to a standstill (time-delayed shut-down of the power supply).
(as SS1 function of IEC/EN61800-5-2)

Category 2 : Controlled stop. The power supply to the drive element is not interrupted. Additional measures to EN 1037 (protection from unexpected restart) are necessary. (as SS2 function of IEC/EN61800-5-2)

How it works

Interrupting the current to GS1 or GS2, for example removing the link between either GS1 or GS2 and PLC or both GS1/GS2 and PLC disables the drive output, i.e. the power supply to the motor is cut by stopping the switching of the output transistors in a safe way. EDM output is activated when GS1 and GS2 are given to the drive.

Always use both inputs to disable the drive. EDM output conducts when both GS1 and GS2 circuits are working properly. If for any reason only one channel is opened, the drive output is stopped but the EDM output is not activated. In this case the Safe Disable input wiring must be checked.

Activation

Turning on the safety switch automatically assign the GS1 input and GS2 input automatically.

To assign EDM (External Device Monitor) output, please turn the EDM function switch on. EDM output is automatically assigned on intelligent output terminal 11.

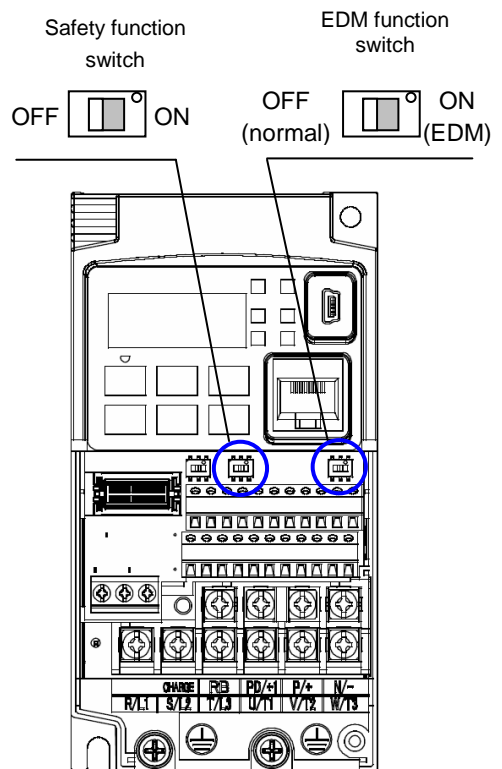

(When safety switch or EDM switch is turned off, the intelligent input and output terminal assigned on will be set as "no" function, and contact will remain normally off.)

Always use both inputs to disable the drive. If for any reason only one channel is opened, the drive output is stopped but the EDM output is not activated. In this case the Safe Disable input wiring must be checked.

Installation

According to the safety standard listed above, please install referring to the example. Please be sure to use the both GS1 and GS2, and construct the system that GS1 and GS2 are both turned off when safety input is given to the inverter.

Be sure to carry out the proof test when installation is ready before operation.

When the Gate Suppress function is utilized, connect the drive to a safety certified interrupting device utilizing EDM output signal to reconfirm both safety inputs GS1 and GS2. Follow the wiring instructions in the Instruction manual.

item	Function code	data	description
Input [3] and [4] function	C003	77	GS1: Safety input 1 (note 1)
	C004	78	GS2 : Safety input 2 (note 1)
Input [3] and [4] active state	C013	01	NC: Normally Closed (note 1)
	C014	01	NC: Normally Closed (note 1)
Output [11] function	C021	62	EDM : External Device Monitor(note2)
Output [11] active state	C031	00	NO: Normally Open (note 2)
		01	Output is shut off by hardware. No trip.
GS input mode	b145	00	Output is shut off by hardware. No trip.
		01	Output is shut off by hardware, and then, trip. (note3) (note4)

Note 1) They are automatically set when safety switch is turned ON, cannot be changed.

Note 2) Those are automatically assigned when EDM switch is turned ON, cannot be changed.

Note 3) Inverter trips with "E37". When competing with external trip (E12), E37 has priority.

Note 4) While the drive is the trip status "E037" and either GS1 or GS2 is activated, on the safety by is not guaranteed.

Wiring example

When the Gate Suppress function is utilized, connect the drive to a safety certified interrupting device utilizing EDM output signal to reconfirm both safety inputs GS1 and GS2. Follow the wiring instructions in the Instruction manual.

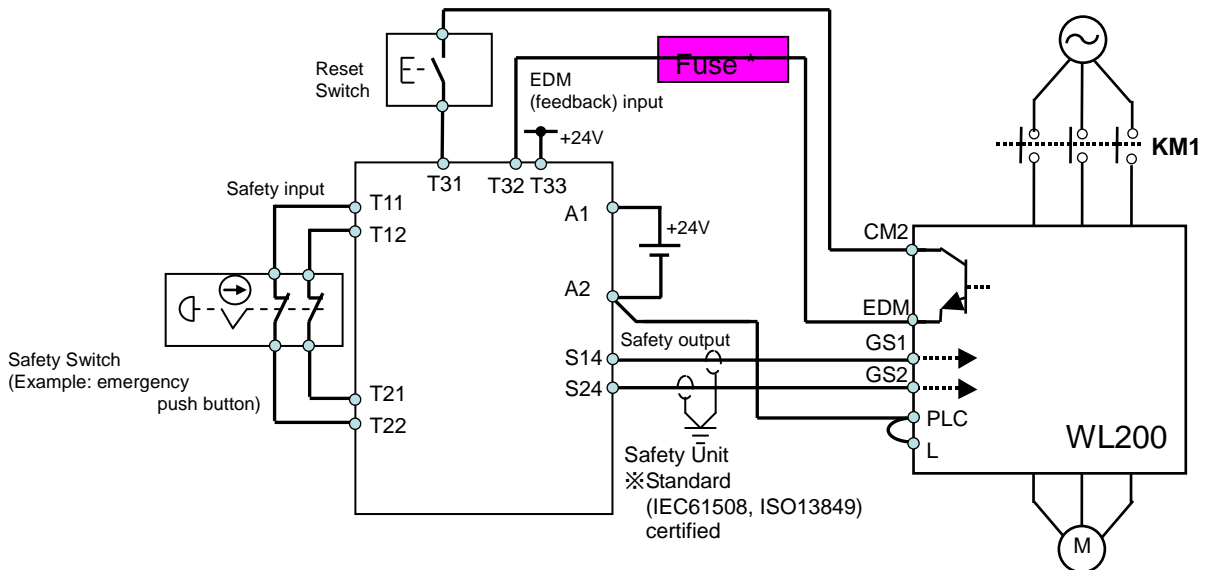

(*) Specification of the fuse:

The arch extinguishing fuse with rated voltage AC250V, rated current 100mA complies to either IEC6127 -2/-3/-4 example) SOC EQ series AC250V, 100mA (UL, SEMKO, BSI)
Little 216 series AC250V, 100mA (CCC, UL, CSA, SEMKO, CE, VDE)

Any external signal voltage connected to the WL200 must be from a SELV Power Supply.

By pressing the emergency stop button, the current to GS1 and GS2 is shut off, and the inverter output is shut off. By this, motor is free-running. This behavior is according to the stop category 0 defined in EN60204.

Note 1: Above is the example to use the intelligent input terminal with source logic. When it is used with sink logic, the wiring is to be modified.

Note 2: The wire for safety relay and emergency input signal are to be shielded coaxial cable for example RS174/U (produced by LAPP) by MIL-C17, or KX2B by NF C 93-550 with diameter 2.9mm with less than 2 meters. Please be sure to ground the shielding.

Note 3: All the inductance related parts such as relay and contactor are required to contain the over-voltage protection circuit.



Inverter doesn't block the current flowing into itself when it is not powered. This may cause the closed circuit when two or more inverters are connected to common I/O wiring as shown below to result in unexpected turning the on the input. This may lead to dangerous situation. To avoid this closed circuit, please put the diode (rated:50V/0.1A) in the path as described below.



IF the protection diodes used when the units are in wired parallel are only single diodes then their condition would be checked as part of the proof test.

By having ability inverter doesn't block the current flowing into itself when it is not powered. This may cause the closed circuit when two or more inverters are connected to common I/O wiring as shown below to result in unexpected turning the on the input. To avoid this closed circuit, please put the diode (rated:50V/0.1A) in the path as described below.

In case of Sink logic

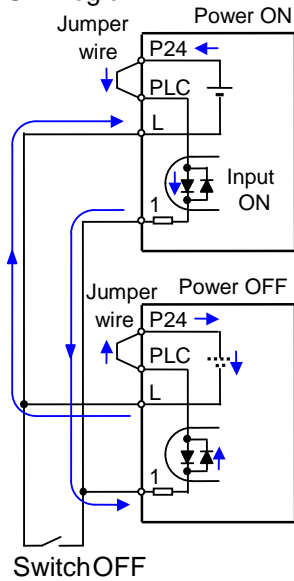

Inserting diode
→

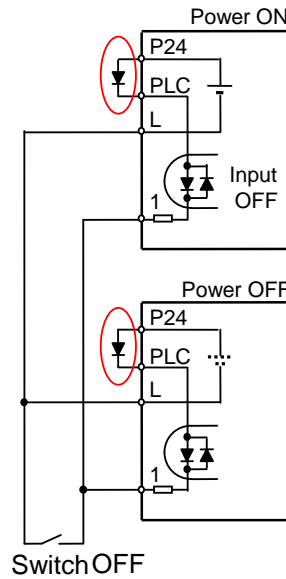

In case of Source logic

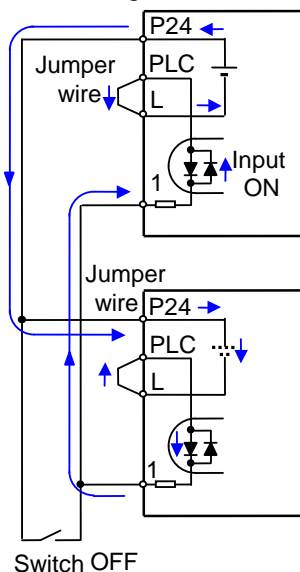

→

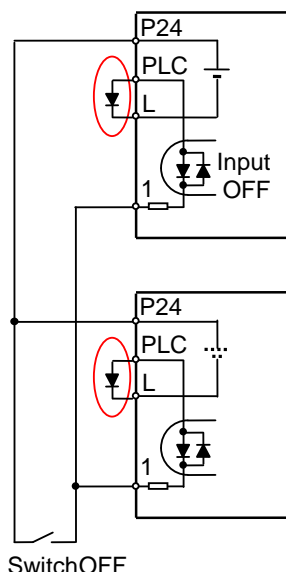

The current loop cause turn the input ON even the switch is off when diode is not inserted.

The current loop is to be prevented by inserting diode instead of short bar.

Components to be combined

Followings are the example of the safety devices to be combined.

Series	Model	Norms to comply	Certification date
GS9A	301	ISO13849-2 cat4, SIL3	06.06.2007
G9SX	GS226-T15-RC	IEC61508 SIL1-3	04.11.2004
NE1A	SCPU01-V1	IEC61508 SIL3	27.09.2006

The configuration of and components used in any circuit other than an appropriately pre approved safety module that interfaces with the WL200 GS1/GS2 and EDM ports MUST be at least equivalent to Cat.3 PLd under ISO 13849-1:2006 in order to be able to claim an overall Cat.3 PLd for the WL200 and external circuit combination.

The EMI level that the external module has been assessed to must be at least equivalent to that of Annex E in IEC 62061.

Periodical check (proof test)

Proof test is essential to be able to reveal any dangerous undetected failures after a period of time, in this case 1 year. Carrying out this proof test at least one a year is the condition to comply the ISO13849-1 PLd.

Terminal	Status			
	current OFF	current ON	current OFF	current ON
GS1	current OFF	current ON	current OFF	current ON
GS2	current OFF	current OFF	current ON	current ON
EDM	conducted	not conducted	not conducted	not conducted
(output)	forbidden	forbidden	forbidden	Allowed

- To activate (give current to) GS1 and GS2 simultaneously and separately to see output is allowed and EDM is conducting
- To activate (give current to) both GS1 and GS2 to see output is allowed and EDM is not conducting
- To activate (give current to) GS1, not to activate GS2 and see output is forbidden and EDM is not conducting
- To activate (give current to) GS2, not to activate GS1 and see output is forbidden and EDM is not conducting
- To deactivate (interrupt current to) both GS1 and GS2 to see output is forbidden and EDM is conducting

Be sure to carry out the proof test when installation is ready before operation.



IF the protection diodes used when the units are in wired parallel are only single diodes then their condition would be checked as part of the proof test. Check to reconfirm the diodes are not damaged when proof test is done.

Precautions



1. To assure, that the Safe Disable function appropriately fulfills the safety requirements of the application, a throughout risk assessment for the whole safety system has to be carried out.
2. The Safe Disable function does not cut the power supply to the drive and does not provide electrical isolation. Before any installation or maintenance work is done, the drives power supply must be switched off and place a tag/lock-out.
3. The wiring distance for the Safe Disable inputs should be shorter than 30 m.
4. The time from opening the Safe Disable input until the drive output is switched off is less than 10 ms.