

Thank you for purchasing a Hitachi Programmable Logic Controller. To operate it safely, please read this instruction manual and all the user manuals carefully. Please be sure to use the latest versions of user manuals and keep them at hand of end users for future reference.

Caution

1. All rights reserved.
2. The content of this manual may be changed without notice.
3. While efforts have been made on this manual to be accurate, please contact us if any mistake or unclear part is found.

■ Warranty period and coverage

The warranty period is within 18 months after manufacturing date (MFG No) or 12 months after installation.

Examination and repair within the warranty period is covered. However within the warranty period, the warranty will be void if the fault is due to;

- (1) Incorrect use from instructed in this manual and the application manual.
- (2) Malfunction or failure of external other devices than this unit.
- (3) Attempted repair by unauthorized personnel.
- (4) Natural disasters.

The warranty is for the PLC only, any damage caused to third party equipment by malfunction of the PLC is not covered by the warranty.

■ Repair

Any examination or repair after the warranty period is not covered. And within the warranty period any repair and examination which results in information showing the fault was caused by any of the items mentioned above, the repair and examination cost are not covered. If you have any questions regarding the warranty or repair cost, please contact your supplier or the local Hitachi Distributor. (Depending on failure part, repair might be impossible.)

■ Ordering spare parts and inquiries

Please contact your local suppliers for ordering products/spare parts or any inquiries with providing the following information.

- (1) Product name
- (2) Manufacturing number (MFG No.)
- (3) Details of failure

Safety precautions

■ Definitions and Symbols



DANGER

Indicates a potentially hazardous situation which, if not avoided, can result in serious injury or death.



CAUTION

Indicates a potentially hazardous situation which, if not avoided, can result in minor to moderate injury, or serious damage of product.



: Indicates Prohibition



: Indicates Compulsion



DANGER

- Do not touch terminals while power ON. There is a danger of electric shock and/or injury.
- Be sure to install external safety devices outside of the PLC like emergency stop circuit or interlock circuit.



CAUTION

- Be sure that the rated voltage matches the power supply voltage of the unit. Otherwise, there is a danger of breakdown and/or injury and/or fire.
- Only qualified personnel shall carry out wiring work. Otherwise, there is a danger of breakdown and/or injury and/or fire.



COMPULSION

- Be sure to ground the unit. Otherwise, there is a danger of electric shock and/or malfunction.



PROHIBITION

- Do not attempt to modify nor disassemble the unit. There is a danger of breakdown and/or injury and/or fire.

■ Mounting

- Mount the PLC on a metal plate and install in a cabinet as follows.
- Be sure to ground the cabinet and the metal plate, otherwise there is a risk of malfunction.
- Install the PLC as described in user manual.
- Take appropriate measures when the PLC system installed in locations:
 - Influenced easily due to noise or static electricity or other forms of noise.
 - Under strong electromagnetic field.
 - Close to power supplies.
- Be sure to tighten mounting screws, terminal screws and connector screws.
- Be sure to check that devices with lock mechanism, such as an expansion cable or terminal blocks, are locked properly.

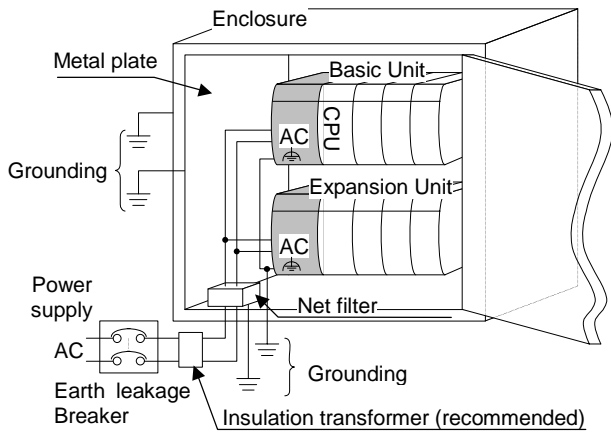

Figure 1 Power wiring example

Table 1 Specifications of the net filter

Item	Spec.	
Rated voltage (V AC)	250	
Rated current (A)	5	
Withstand voltage (V) (between Terminal and case)	1,500	
Insulation resistance (MΩ) (500V DC, 1min., between terminal and case)	100 (min.)	
Attenuation characteristic (dB)	0.5 to 30 MHz	Common mode more than 40dB
	0.15 to 30 MHz	Differential mode more than 40dB

■ Power Wiring

- Appropriate emergency circuitry, interlock circuitry and similar safety measures should be added to the system.
- Appropriate safety measures should be included in the system for unexpected breaking of wire or malsignal caused from instantaneous power failure.
- Applied voltage must be in the range specified in the manual. Otherwise, there is a danger of breakdown and/or injury and/or fire.
- Install an external earth leakage breakers to avoid short circuit accident.
- In case of the following operations, turn off power. Otherwise, there is a danger of breakdown and/or injury and/or fire.
 - Mounting or dismounting CPU and I/O modules.
 - Assembling cabinet or machine including PLC.
 - Wiring.
- Install net filter specified in Table 1 or similar. The input and output cable of the net filter should be separated as much as possible. Be sure to ground the net filter.
- A shielded and insulated transformer is recommended.
- The basic and expansion unit should be connected to common power source and powered up together as shown in Figure 1.
- To install an arrester in each power wire is recommended in order to prevent lightning damage and/or injury.

■ I/O Wiring

- Be sure that the input/output matches the specified voltage. Otherwise, there is a danger of breakdown and/or fire.
- Use shielded cable for relay outputs modules, and connect shields to a functional ground for one side or both sides depending on applications.
- Route the AC power line and I/O lines separated as much as possible. Do not route both cables in a same duct.
- Route the I/O lines and data lines as close as possible to the grounded surfaces such as cabinet elements, metal bars and cabinets panels.
- Refer to the following table.

Electric wire for wiring			Terminal tightening torque
Size	Material	Type	
22-14 AWG	Copper	Single/twisted wire available	9in. -1bs (1.02 Nm)

■ Common precautions

- Use proper cable ferrules for terminals. Using improper cable ferrules or connecting bare wires to terminals directly might result in fire.
- Do not turn on power, if the unit appears damaged.
- Be sure to check all the field wiring before PLC power on. Otherwise, there is a risk of fire.
- Do not attempt to disassemble, repair or modify any part of the PLC.
- Do not pull on cables or bend cables beyond their natural limit. Otherwise, there is a risk of breaking of wire.
- Keep PLC modules in their boxes during storage and transport.
- Check carefully your PLC program before operation.

Installation environment

Avoid the following locations to install the PLC.

- Excessive dusts, salty air, or conductive materials (iron powder, etc.)
- Direct sunlight.
- Temperature less than 0°C or more than 55° C.
- Humidity less than 5% or more than 95%.
- Dew condensation.
- Direct vibration or impact to the unit.
- Corrosive, explosive or combustible gases.
- Water, chemicals or oil splashing on the PLC.
- Close to noise emission devices.

Reference Manual

Read the following application manual carefully depends on series to use the PLC safely and properly. Be sure to keep the latest version.

Manual name	Manual No.
EHV-CPU APPLICATION MANUAL	NJI-481* (X)
EHV-150 APPLICATION MANUAL	NJI-281* (X)

* The alphabet between 481 and (X) means version (A, B...) and the space means the first edition.

Specifications

■ General specifications

Item	Specifications
Operating ambient temperature	0 to 55 °C (0 to 45 °C if used as UL certified product)
Storage ambient temperature	-10 to 75 °C
Operating ambient humidity	5 to 95 % RH (no condensation)
Storage ambient humidity	5 to 95 % RH (no condensation)
Vibration resistance	Conforms to IEC 60068-2-6
Noise resistance	<ul style="list-style-type: none"> ○ Noise voltage 1,500 Vpp Noise pulse width 100 ns, 1μs (Noise created by the noise simulator is applied across the power supply module's input terminals. This is determined by this company's measuring method.) ○ Based on IEC61131-2 ○ Static noise: 3,000 V at metal exposed area
Insulation resistance	20 MΩ or more between the AC external terminal and case ground (FE) terminal (based on 500 V DC)
Dielectric withstand voltage	1,500 V AC for 1 minute between the AC external terminal and case ground (FE) terminal
Grounding	Class D grounding (ground with power supply module)
Usage environment	No corrosive gases, no excessive dust
Structure	Open, wall-mount type
Cooling	Natural air cooling

■ Performance specification

Item	Specification		
Type	EH-AXG5M		
Number of channel	Differential 5 voltage or 5 current input		
Input range Selectable by the DIP switch	Voltage	0 to 10 V DC	
		-10 to 10 V DC	
	Current	0 to 22 mA	
		4 to 22 mA	
Resolution Selectable by the DIP switch	High resolution mode		12 bit mode
	0 to 10 V	0 to 64000 [0.15625 mV]	0 to 4095 [2.442 mV]
	-10 to 10 V	-32000 to 32000 [0.3125 mV]	-2048 to 2047 [4.884 mV]
	0 to 22 mA	0 to 64000 [0.34375 μA]	0 to 4095 (20mA) [4.884 μA]
	4 to 22 mA	-7111 to 32000 [0.5625 μA]	0 to 4095 (20mA) [3.907 μA]
Conversion time	High accuracy mode		High speed mode
	8 ms / 5 channel		0.25 ms / 5 channel
Accuracy (FS) *1	At 25 °C	-0.05 to +0.05 %	
	Temperature coefficient	-80 to +80 ppm / °C (0.008 % / °C)	
Input filter	1 kHz		
Input impedance	Voltage	Differential 200 k Ω	
	Current	249 Ω	
Warm up time	More than 15 minutes		
Absolute maximum ratings	Voltage: -15 to 15 V Current :30 mA*2		
Isolation type	Channel - internal circuit	Transformer (1,000V AC, 1 minutes)	
	Between channels	Transformer (1,000V DC, 1 minutes)	
Weight	Approximately 0.15 kg		
External wiring	Removable terminal (M3)		
Internal current consumption (5 V DC)	Max. 300mA		
External power wiring	None		
Wiring	Twisted shield cable (2-pair, less than 20 m)		

*1: e.g. Accuracy at 40 °C is calculated as follows,

$$0.05 \% (\text{accuracy at } 25 \text{ } ^\circ\text{C}) + 0.008 \% / \text{ } ^\circ\text{C} (\text{Temperature coefficient}) * 15 \text{ } ^\circ\text{C} (\text{difference from } 25 \text{ } ^\circ\text{C}) = 0.17 \%$$

*2: It is the momentary current value that does not destroy the resistance in the module.

■ Name and function of each part

	Model name	EH-AXG5M
	Weight	Approx. 0.15 kg
	Consumption current (5VDC)	Approx. 300 mA
	Dimensions (mm (in.))	

No.	Name	Function	Remarks
1]	Lock button	This is used when removing the module from base unit. After it is installed to the base unit, the fixation can be reinforced using screws. In this case, use M4 × 10 mm (0.39 in.) screw.	
2]	I/O cover	This is the cover attached to the terminal block area.	
3]	Terminal	This is the terminal block for connecting input signals. The terminal block can be connected or disconnected.	
4]	Mode setting DIP switch	This is a switch to set Input range, input filter and resolution.	Refer to Mode setting DIP switch
5]	LED display	<p>The status of module is displayed on this LED.</p> <p>OK : Light up when this module is normal</p> <p>HS : Light up when this module is high speed conversion mode</p> <p>Light is turned off when this module is high accuracy mode</p> <p>16b : Light up when this module is high resolution mode</p> <p>12b : Light up when this module is 12 bit resolution mode</p> <p>0 to 4 : In case of 4 to 22mA range, if input current is less than 2mA the LED of each channel is blinking.</p>	<p>Refer to Mode setting DIP switch</p> <p>This function is available as wire breaking.</p>

Item	Detail explanation	Remarks
Explanation of operation	<p>It is possible to input 5 DC voltage or current, each input is isolated.</p> <p>The CPU module verifies the status of the installed module and if the I/O assignment information matches that contained in the user program, the input information is received according to the contents of the user program.</p>	
Terminal block	<p>The screws for the terminal block are M3 screws. Use a crimp terminal that fits the screw diameter. The maximum thickness of the cable should be only up to 0.75 mm². (Use 0.5 mm² cable when two crimp terminals are attached to the same terminal.)</p> <p>The recommended crimp terminal is indicated below.</p> <p>(Recommended)</p> <p>Care must be exercised when handling the terminal since it may fall off if the screw is loose.</p> <p>Unit : mm</p>	

Terminal layout and internal circuit

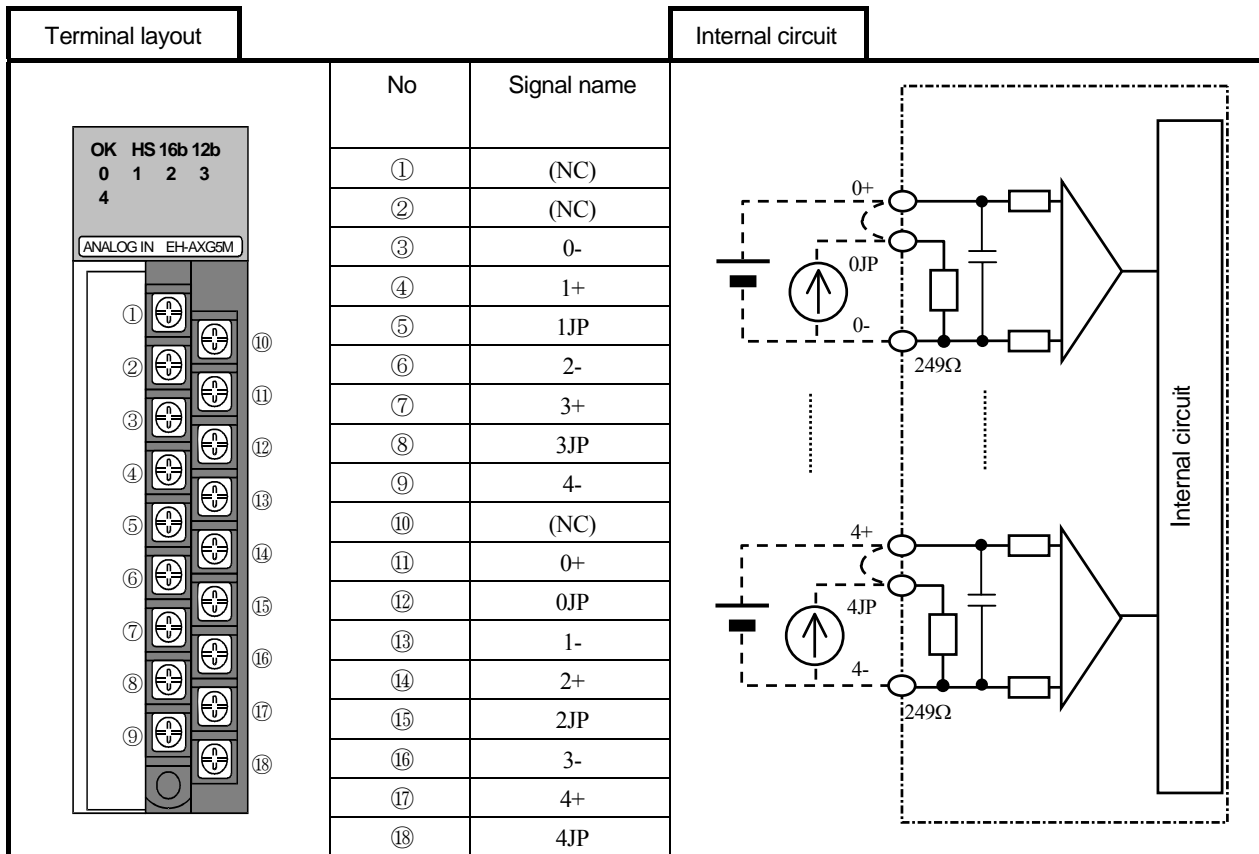

■ Mode setting DIP switch

Please set the DIP switch before use. If change the DIP switch while power on, the setting is same as before.

[Black part is factory setting]

No.	Setting		Function
1, 2	1	2	Input range
	OFF	OFF	0 to 10 V DC
	ON	OFF	-10 to 10 V DC
	OFF	ON	0 to 22 mA
	ON	ON	4 to 22 mA
3, 4	3	4	Moving Average data number
	OFF	OFF	Not use moving Average
	ON	OFF	4
	OFF	ON	16
	ON	ON	64
5	5		Resolution
	OFF		High resolution mode (equally 16 bit)
	ON		12 bit mode
6	6		Conversion time
	OFF		High accuracy, 8ms (whole channel)
	ON		High speed, 0.25ms (whole channel)
7	7		For system
	OFF		Always OFF (should not turn ON)
8	8		For system
	OFF		Always OFF (should not turn ON)

* In case switch 5 turn OFF and switch 6 turn ON, It is available High resolution and High speed mode (16bit, 0.25ms). Please be careful using this mode because this mode is very sensitive for noise.

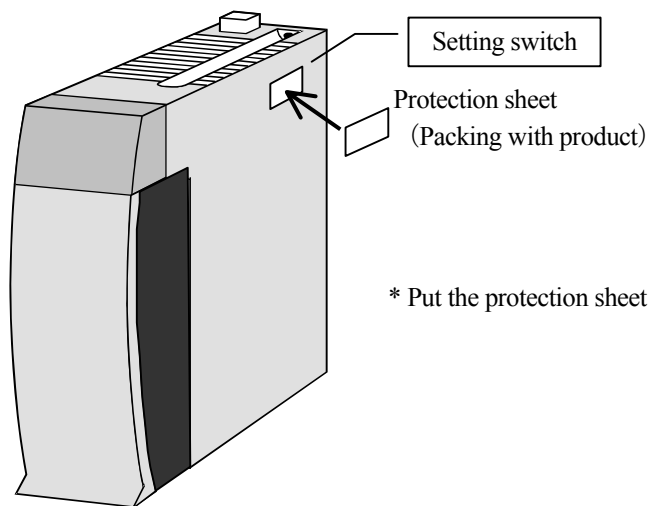

* Put the protection sheet after setting for safety.

Conversion value

(1) 0 to 10V range

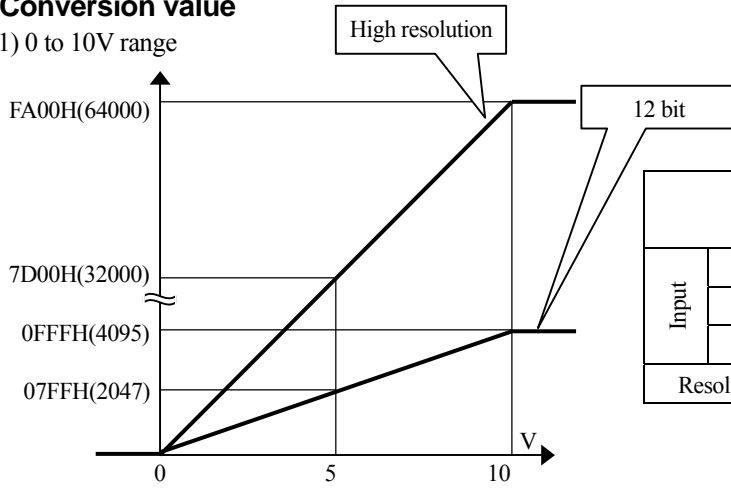

		High resolution		12 bit	
		Decimal	Hexadecimal	Decimal	Hexadecimal
Input	10V	64000	FA00H	4095	0FFFH
	5V	32000	7D00H	2047	07FFH
	0V	0	0000H	0	0000H
Resolution		0.15625 mV		2.442 mV	

(2) -10 to 10V range

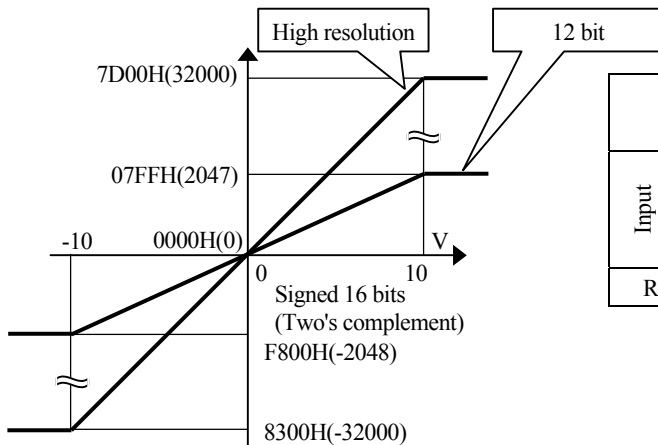

		High resolution		12 bit	
		Decimal	Hexadecimal	Decimal	Hexadecimal
Input	10V	32000	7D00H	2047	07FFH
	0V	0	0000H	0	0000H
	-10V	-32000	8300H	-2048	F800H
Resolution		0.3125 mV		4.884 mV	

(3) 0 to 22mA range

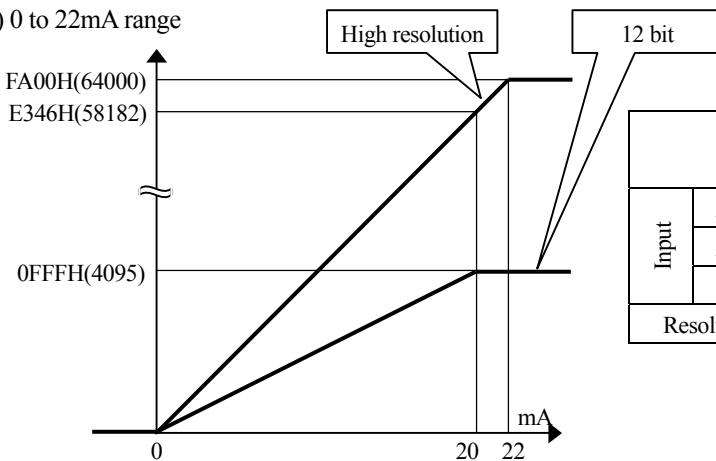

		High resolution		12 bit	
		Decimal	Hexadecimal	Decimal	Hexadecimal
Input	22mA	64000	FA00H	4095	0FFFH
	20mA	58182	E346H	4095	0FFFH
	0mA	0	0000H	0	0000H
Resolution		0.34375 μ A		4.884 μ A	

(4) 4 to 22mA range

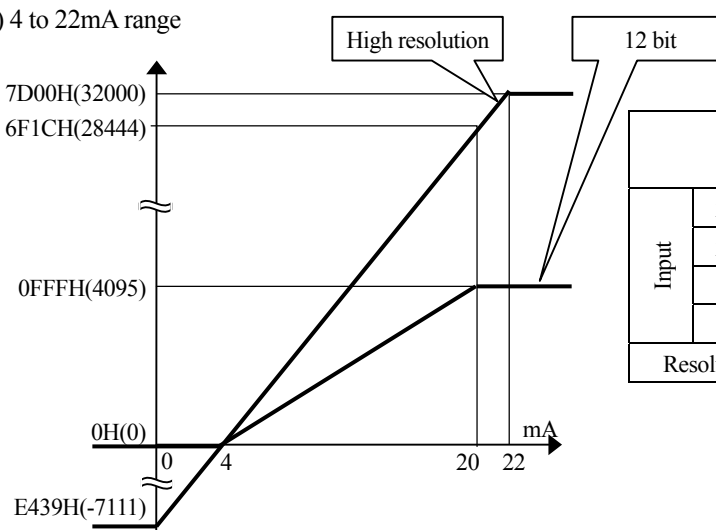

		High resolution		12 bit	
		Decimal	Hexadecimal	Decimal	Hexadecimal
Input	22mA	32000	7D00H	4095	0FFFH
	20mA	28444	6F1CH	4095	0FFFH
	4mA	0	0000H	0	0000H
	0mA	-7111	E439H	0	0000H
Resolution		0.5625 μ A		3.907 μ A	

■ Caution

(1) Treatment for out of the input range

Input signal out of the range is converted to the max. or min. value as follows.

Ex. :

Input range	Input signal	Input value	
		High resolution	12 bit
0 to 22 mA	23 mA	64000 (Decimal)	4095 (Decimal)
-10 to 10 V	-11 V	-32000 (Decimal)	-2048 (Decimal)
4 to 22 mA	1 mA	-1778 (Decimal)	0 (Decimal)

(2) LED indication

LED	Lighting	Blinking	Off
OK	Normal operation	Module error. (Contact your local supplier.)	- No power supplied - Module error (Contact your local supplier.)
HS	High speed mode	-	High accuracy mode
16b	High resolution mode	-	12 bit mode
12b	12 bit mode	-	High resolution mode
0 to 4	-	Wire breaking (2mA input or less in case of 4 to 22mA range)	Normal operation

(3) Wire breaking monitor

Wire breaking of each channel can be monitor in EHV series using Exp. input.

WEX**00

bit 15 to 13	bit 12	bit 11	bit 10	bit 9	bit 8	bit 7 to 0
Not use	Channel 4	Channel 3	Channel 2	Channel 1	Channel 0	Not use

If EH-AXG5M detect the wire breaking above Exp. input will turn on.

(In case of input less than 2mA at High resolution mode and 4 to 22mA range)

(4) Wiring

Since analog signal is very sensitive, be sure to use shielded cable in order to protect from noise, and route the cable apart from other power/signal cables.

Be sure to ground the shield at one end basically. But grounding at both ends or no grounding can be more effective depending on system environment.

