

H Series PLC HITACHI

EH-150 Thermocouple input module

EH-TC8 Instruction manual

Thank you for purchasing a Hitachi Programmable Logic Controller. To operate it safely, please read this instruction manual and all the user manuals carefully. Please be sure to use the latest versions of user manuals and keep them at hand of end users for future reference.

Caution

1. All rights reserved.
2. The content of this manual may be changed without notice.
3. While efforts have been made on this manual to be accurate, please contact us if any mistakes or unclear part is found.

Warranty period and coverage

The warranty period is either 18 months after manufacturing date (MFG No) or 12 months after installation. Examination and repair within the warranty period is covered.

However within the warranty period, the warranty will be void if the fault is due to;

- (1) Incorrect use from instructed in this manual and the application manual.
- (2) Malfunction or failure of external other devices than this unit.
- (3) Attempted repair by unauthorized personnel.
- (4) Natural disasters.

The warranty is for the PLC only, any damage caused to third party equipment by malfunction of the PLC is not covered by the warranty.

Repair

Any examination or repair after the warranty period is not covered. And within the warranty period any repair and examination which results in information showing the fault was caused by any of the items mentioned above, the repair and examination cost are not covered. If you have any questions regarding the warranty or repair cost, please contact your supplier or the local Hitachi Distributor. (Depending on failure part, repair might be impossible.)

Ordering spare parts and inquiries

Please contact your local suppliers for ordering products/spare parts or any inquiries with providing the following information.

- (1) Product name
- (2) Manufacturing number (MFG No.)
- (3) Details of failure

Safety precautions

Definitions and Symbols



DANGER

Indicates a potentially hazardous situation which, if not avoided, can result in serious injury or death.



CAUTION

Indicates a potentially hazardous situation which, if not avoided, can result in minor to moderate injury, or serious damage of product.



: Indicates prohibition



: Indicates Compulsion



DANGER

- Do not touch terminals while power ON. There is a danger of electric shock and/or injury.
- Be sure to install external safety devices outside of the PLC like emergency stop circuit or interlock circuit.



CAUTION

- Be sure that the rated voltage matches the power supply voltage of the unit. Otherwise, there is a danger of breakdown and/or injury and/or fire.
- Only qualified personnel shall carry out wiring work. Otherwise, there is a danger of breakdown and/or injury and/or fire.



COMPULSION

- Be sure to ground the unit. Otherwise, there is a danger of electric shock and/or malfunction.



PROHIBITION

- Do not attempt to modify nor disassemble the unit. There is a danger of breakdown and/or injury and/or fire.

Mounting

- Mount the PLC on a metal plate and install in a cabinet as follows.
- Be sure to ground the cabinet and the metal plate, otherwise there is a risk of malfunction.
- Install the PLC as described in user manual.
- Take appropriate measures when the PLC system installed in locations :
 - Influenced easily due to noise or static electricity or other forms of noise.
 - Under strong electromagnetic field.
 - Close to power supplies.
- Be sure to tighten mounting screws, terminal screws and connector screws.
- Be sure to check that devices with lock mechanism, such as an expansion cable or terminal blocks, are locked properly.

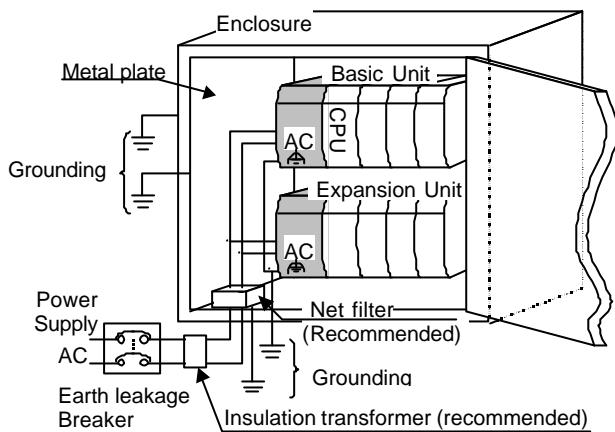

Figure 1 Power wiring example

Table1 Specifications of the net filter

Item		Spec.
Rated voltage		250 VAC
Rated current		5 A
Withstand voltage (V) (between Terminal and case)		1500 V
Insulation resistance (M) (500VDC, 1 min., between terminal and case)		min. 100 M
Attenuation Frequency range (MHz)	Differential mode, more than 40dB	0.5 - 30
	Common mode, more than 40dB	0.15 - 30

Reference : EMC filter ZAC2205-00U (TDK)

■ Power Wiring

- Appropriate emergency circuitry, interlock circuitry and similar safety measures should be added to the system.
- Appropriate safety measures should be included in the system for unexpected breaking of wire or malsignal caused from instantaneous power failure.
- Applied voltage must be in the range specified in the manual. Otherwise, there is a danger of breakdown and/or injury and/or fire.
- Install an external earth leakage breakers to avoid short circuit accident.
- In case of the following operations, turn off power. Otherwise, there is a danger of breakdown and/or injury and/or fire.
 - Mounting or dismounting CPU and I/O modules.
 - Assembling cabinet or machine including PLC.
 - Wiring.
- Install net filter specified in table-1 or similar. The input and output cable of the net filter should be separated as much as possible. Be sure to ground the net filter.
- A shielded and insulated transformer is recommended.
- The basic and expansion unit should be connected to common power source and powered up together as shown in fig.1.

■ I/O Wiring

- Be sure that the input/output voltage matches the specified voltage. Otherwise, there is a danger of breakdown and/or fire.
- Use shielded cable for relay outputs module, and connect shields to a functional ground for one side or both sides depending on applications.
- Route the AC power line and I/O lines separated as much as possible. Do not route both cables in a same duct.
- Route the I/O lines and data lines as close as possible to the grounded surfaces such as cabinet elements, metal bars and cabinets panels.

■ Common precautions

- Use proper cable ferrules for terminals. Using improper cable ferrules or connecting bare wires to terminals directly might result in fire.
- Do not turn on power, if the unit appears damaged.
- Be sure to check all the field wiring before PLC power on. Otherwise, there is a risk of fire.
- Do not attempt to disassemble, repair or modify any part of the PLC.
- Do not pull on cables or bend cables beyond their natural limit. Otherwise, there is a risk of breaking of wire.
- Keep PLC modules in their boxes during storage and transport.
- Check carefully your PLC program before operation.

Installation environment

- Avoid the following locations to install the PLC.
- Excessive dusts, salty air, or conductive materials (iron powder, etc.)
 - Direct sunlight.
 - Temperature less than 0°C or more than 55°C.
 - Humidity less than 20% or more than 90%.
 - Dew condensation.
 - Direct vibration or impact to the unit.
 - Corrosive, explosive or combustible gases.
 - Water, chemicals or oil splashing on the PLC.
 - Close to noise emission devices.

■ Reference Manual

Read the following application manual carefully to use the PLC safely and properly. Be sure to keep the latest version.

Manual name	Manual No.
EH-150 APPLICATION MANUAL	NJI-281* (X)

* : The alphabet between 281 and (X) means version (A,B...).

1 Name and function

	Type	EH-TC8
	Weight	Approx. 160 g
	Dimension (mm)	

No.	Name	Function	Remarks
[1]	Lock button	When dismantling the module from a base unit, press this button and lift up the module. The module can be fixed firmly by a screw (M4, 10 mm (0.39 in.)).	
[2]	I/O cover	This is the cover attached to the terminal block. The accuracy is adjusted based on the I/O cover attached. If cold junction compensation is enabled, be sure to attach the cover. In order to attach the cover properly, recommended cable diameter (external diameter of pair cable) is 2.5mm in case of all channels used.	
[3]	Terminal block	This is the terminal block for connecting input signals. The terminal block is removable.	
[4]	Mode setting DIP switch	DIP switch for temperature range	
[5]	LED	Module status and thermocouple status indicated. Number LED blinks at error detected channel. OK LED lights in normal operation.	

Item	Detailed explanation	Remarks
Operation	The module receives input signals from thermocouple element. The CPU module recognizes the status of the loaded module and when it matches the I/O assignment information included in the user program, input information is received according to the contents of the user program.	
Terminal block	<p>The screws for the terminal block are M3 screws. Use a crimp terminal that fits the screw diameter. The maximum thickness of the cable should be only up to 0.75 mm². (Use 0.5 mm² cable when two crimp terminals are attached to the same terminal.)</p> <p>The recommended crimp terminal is indicated below.</p> <p>Unit: mm (in.)</p>	

2 Specification

Function specification

Item		Specification	
Model name		EH-TC8	
Supported thermocouple (Selected by DIP switch)		Type K, E, J, T, B, R, S, N	
Temperature data		Signed 15 bits	
Temperature range and accuracy (*1)	Type	Accuracy guaranteed range	Input range
	K	-200 to 1200 °C 0.4% (FS)	-270 to 1370 °C
	E	-200 to 900 °C 0.3% (FS)	-270 to 1000 °C
	J	-40 to 750 °C 0.3% (FS)	-270 to 1200 °C
	T	-200 to 350 °C 0.8% (FS)	-270 to 400 °C
	B	600 to 1700 °C 1.0% (FS)	0 to 1820 °C
	R	0 to 1600 °C 1.0% (FS)	-50 to 1760 °C
	S	0 to 1600 °C 1.0% (FS)	-50 to 1760 °C
Cold junction compensation accuracy		± 2 °C or less (ambient temp. 15 to 35 °C)	
		± 3 °C or less (ambient temp. 0 to 55 °C)	
Resolution	K, E, J, T, N	0.1 °C / 0.1 ° F	
	B, R, S	1.0 °C / 1.0 ° F	
No. of channels		8 channel	
Update cycle (selectable by dip switch)		108 / 860ms	
Isolation	Between channels	Not isolated	
	Between channel and backplane bus	Isolated by photo coupler	
External power supply		24V DC ±10% Max. 100mA	
Internal current consumption (5VDC)		Max. 70mA	
External wiring (*2)		Max. 100 m , Shielded cable	
Diagnostic error	Over flow or breaking wire	Input data : H7FFF (LED blinking at error channel)	
	Under flow	Input data : H8000	
I/O assignment		X8W	
Operational temperature / humidity		0 to 55 °C / 20 to 90%RH (no condensation)	
Storage temperature / humidity		-10 to 75 °C / 10 to 90%RH (no condensation)	

*1) Overall error is sum of accuracy for each sensor and accuracy of cold junction compensation. Error of thermocouple is not included in above accuracy.

*2) Above accuracy is guaranteed under the condition of 10 minutes after power ON. Error just after power on could be bigger.

*3) Maximum cable length of thermocouple is 100 m however, it depends on environment of applications.

Data in WX0-7 is 10 times multiplied temperature as below.

Example) Basic unit, slot 3, Channel 2, 123.4 °C : WX32 = 1234 (H04D2)
Expansion unit 2, slot 5, Channel 7, 100 °C : WX257 = 1000 (H03E8)
Basic unit, slot A Channel 5, -25.6 °C : WXA5 = 65280 (HFF00)

Negative value is given as 2's complement. (subtract absolute value from 65536 (H0000)).

Example) Basic unit, slot A, Channel 5, -25.6 °C : WXA5 = 65536-256 = 65280 (HFF00)

Negative value is converted to absolute value by ABS command as below.

ABS (WM0 , WXA5) <== WM0 will be 256

3 Terminal layout and internal circuit

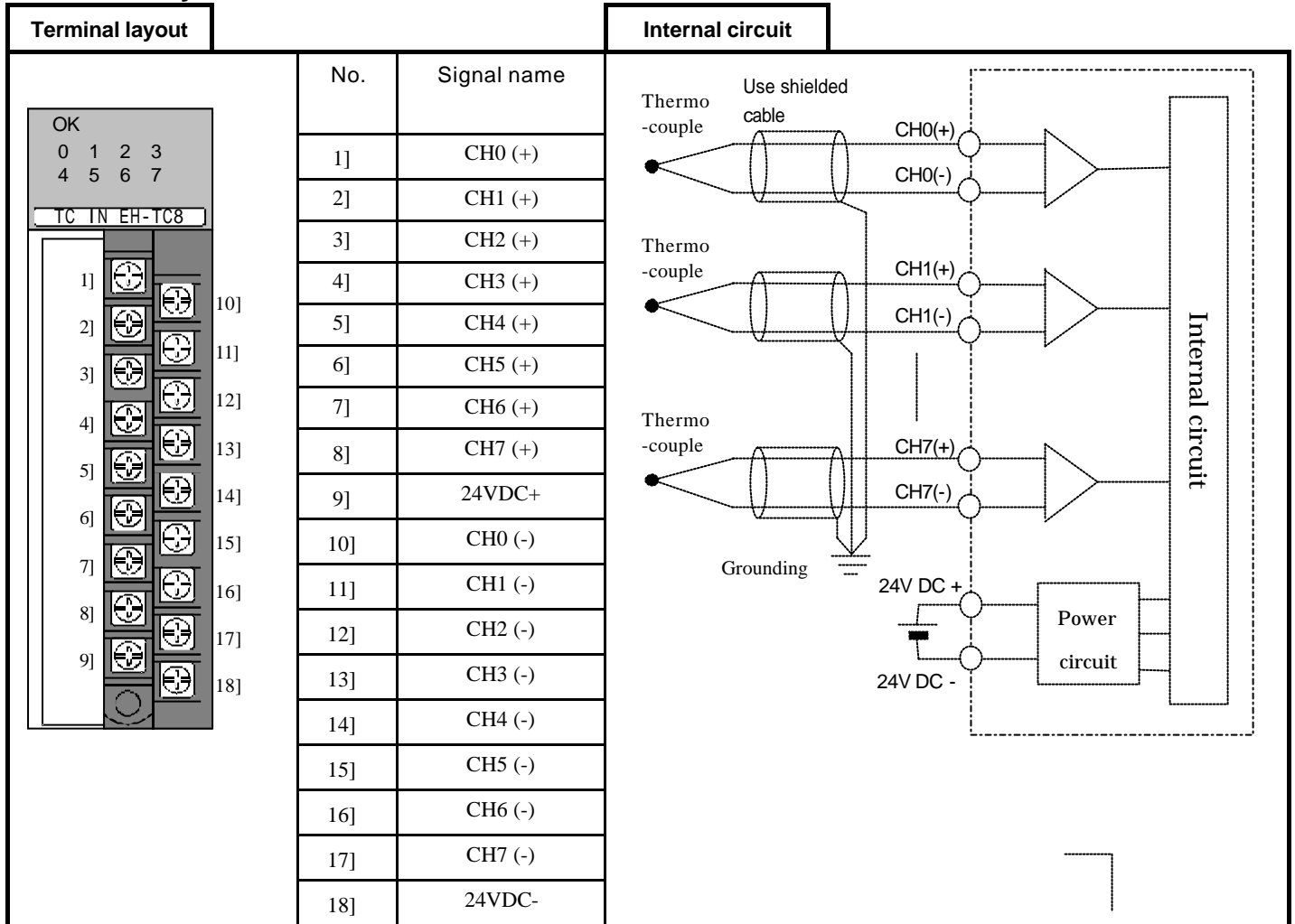

4 Wiring of thermocouple

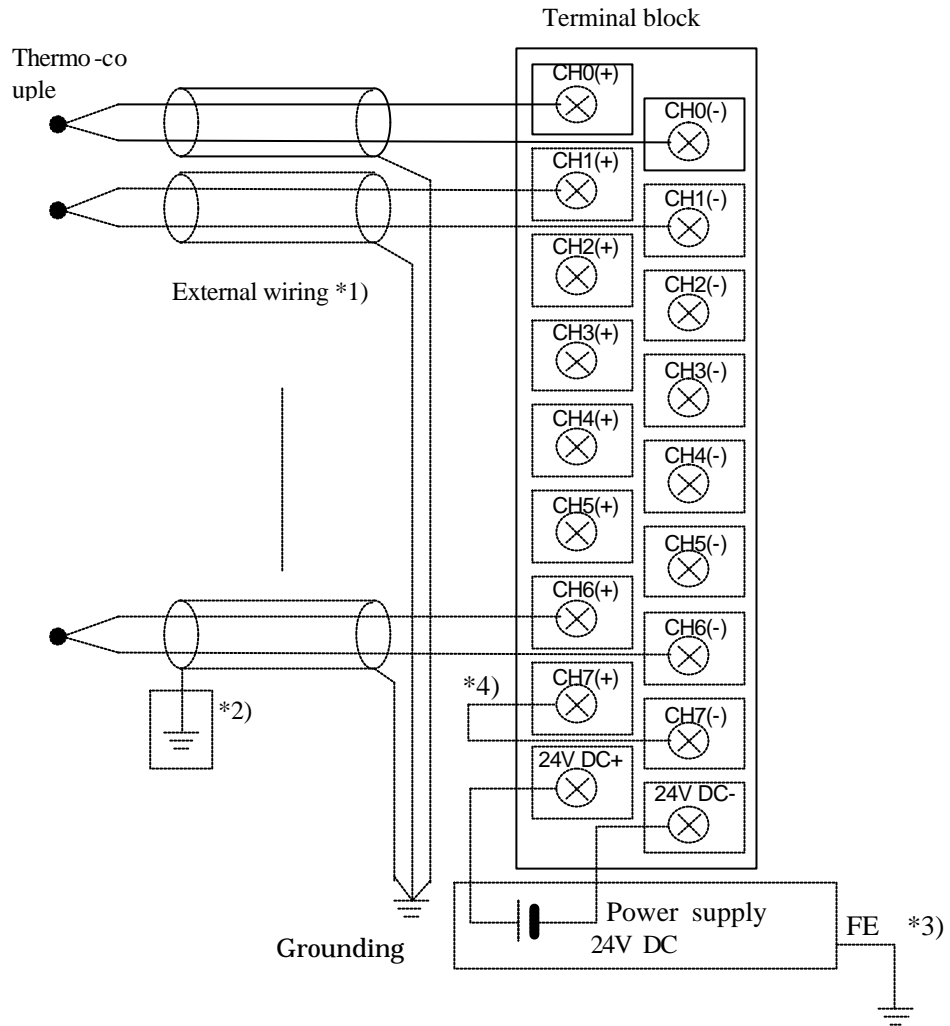

*1) Use shielded cable for thermocouples.

*2) Either end of the shield should be grounded in principle, but sometimes both ends or no grounding could be effective depending on noise environment.

*3) Power supply module and FE terminal of external 24VDC power supply must be grounded, otherwise measured temperature data could be unstable.

*4) LED at open channel will blink. To avoid it, make short circuit between (+) and (-) terminal. In this case, input data is undefined.

5 Mode setting switch

Be sure to set dip switch before power ON. Dip switch information is not updated while power ON.

Table 5.1 Mode setting DIP switch

Switch No.	Setting			Function
1, 2, 3	1	2	3	Thermocouple sensor type (Common for all channels)
	OFF	OFF	OFF	Type K
	ON	OFF	OFF	Type E
	OFF	ON	OFF	Type J
	ON	ON	OFF	Type T
	OFF	OFF	ON	Type B
	ON	OFF	ON	Type R
	OFF	ON	ON	Type S
	ON	ON	ON	Type N
4	4			Celsius / Fahrenheit switching (Common for all channels)
	OFF			Celsius (°C)
	ON			Fahrenheit (°F)
5	5			Data update cycle (Common for all channels)
	OFF			860 ms
	ON			108 ms
6	6			Cold junction compensation (Common for all channels) *1)
	OFF			Enabled
	ON			Disabled
7	7			(system mode)
	OFF			always OFF
8	8			(system mode)
	OFF			always OFF

*1) Accuracy can be better by using external ice bus with cold junction compensation setting disabled.

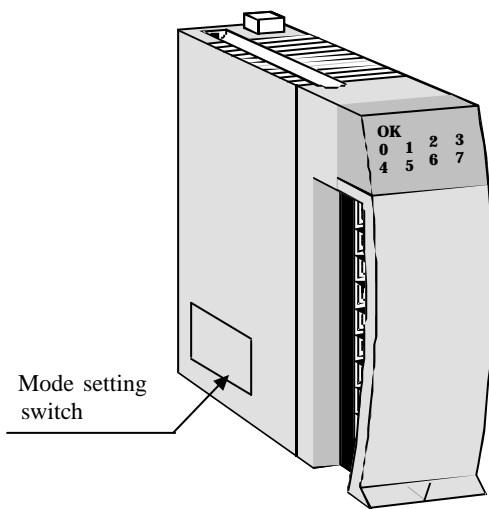

Table 5.2 Default setting

Switch No.	Position	
1	OFF	Thermocouple : Type K
2	OFF	
3	OFF	
4	OFF	Celsius (°C)
5	OFF	Data update cycle 860ms
6	OFF	Cold junct. enabled
7	OFF	(system mode)
8	OFF	(system mode)

*) Be careful to set the dip switch without contacting other components mounted around.

6 Installation

This product is very sensitive for ambient temperature. Please implement installation and wiring after reading carefully the chapter 9 of EH-150 application manual NJI-280*.

- (1) Install the module within specified installation range.
- (2) Be sure to mount grounded metal plate.
- (3) Be sure to install in a grounded cabinet having lock mechanism opened by key or special tool.
- (4) Be sure to ensure proper air flow for cooling, and keep operation temperature.
- (5) Be sure to attach I/O cover on the terminal block.

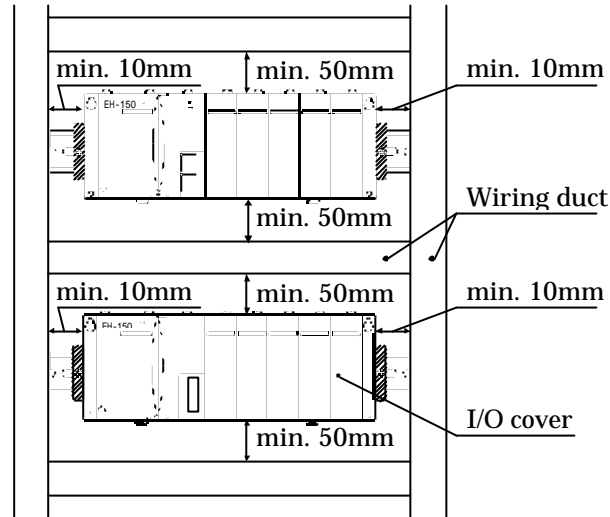

7 Caution for Wiring

Since signal level is very small, use shielded cable, and route apart from power line and different voltage level lines as much as possible to avoid to be influenced by noise.

Either end of the shield should be grounded in principle, but sometimes both ends or no grounding could be effective depending on noise environment.

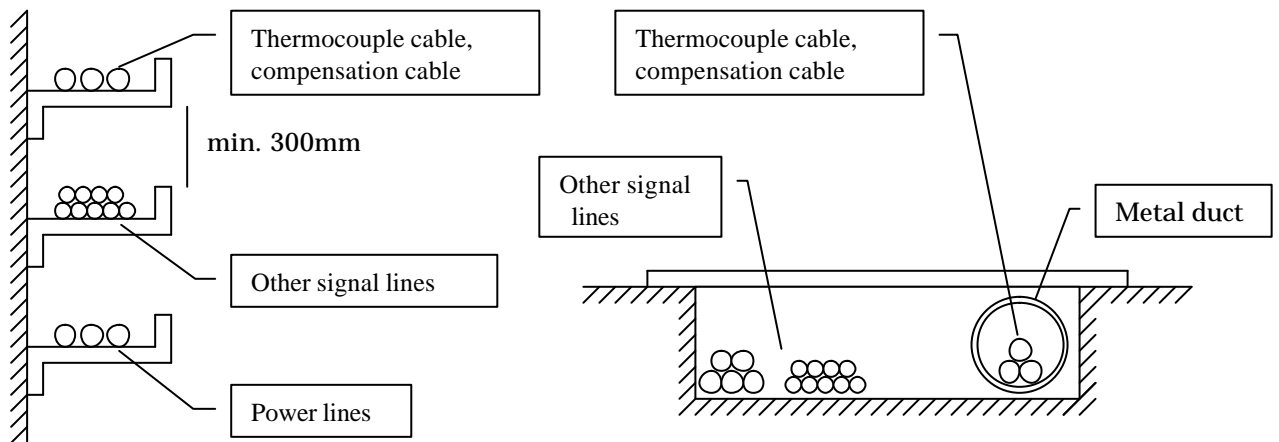

(Caution) Metal duct joint should be welded, and the duct should be grounded.

Fig. 7.1 Wiring separation by duct.