

MODBUS RTU Network Adapter Light

RIO3-MBRL User manual



DOCUMENT CHANGE SUMMARY				
REV	PAGE	REMARKS	DATE	EDITOR
1.00	New Document		Feb 2021	Faber
1.00	37	Remove product list table and add a reference	Aug 2021	Faber

Contents

1. Important Note	5
1.1. Safety Instruction	6
1.1.1. Symbols	6
1.1.2. Safety Notes	6
1.1.3. Certification	6
2. Specification	7
2.1. Interface	7
2.1.1. RIO3-MBRL	7
2.2. Specification	8
2.2.1. General Specification.....	8
2.2.2. Interface Specification	9
2.3. LED Indicator	10
2.3.1 MOD (Module Status LED).....	10
2.3.2 RXD (Receive Data LED).....	10
2.3.3 TXD (Transmit Data LED).....	10
2.3.4 IOS LED (Extension Module Status LED)	10
3. Dimension	11
3.1. RIO3-MBRL	11
4. Mechanical Set Up	12
4.1. Total Expansion	12
4.2. Plugging and Removal of the Components	12
5. MODBUS Electrical Interface	12
5.1. G-Bus System	14
5.3. RIO3-MBRL Electrical Interface.....	16
5.3.1. RJ-45 Socket	16
5.3.2. MODBUS Dip Switch Setup	16
5.3.3. Process Image Map.....	17
5.3.4. MODBUS Interface Register/Bit Map	17
5.4. Example	18
5.4.1. Example of Input Process Image (Input Register) Map	18
5.4.2. Example of Output Process Image (Output Register) Map	19
6. MODBUS TCP/UDP INTERFACE	20
6.1 MODBUS TCP/ UDP Protocol	20

6.1.1. Comparison of MODBUS TCP/UDP and MODBUS/RTU	20
6.1.2. MODBUS TCP/ UDP MBAP Header	21
6.2 Supported MODBUS Function Codes.....	21
6.2.1. 1(0x01) Read Coils	22
6.2.2. 2(0x02) Read Discrete Inputs	22
6.2.3. 3(0x03) Read Holding Registers.....	23
6.2.4. 4 (0x04) Read Input Registers	23
6.2.5. 5 (0x05) Write Single Coil	24
6.2.6. 6 (0x06) Write Single Register	25
6.2.7. 8 (0x08) Diagnostics	25
6.2.8. 15 (0x0F) Write Multiple Coils.....	27
6.2.9. 16 (0x10) Read/Write Multiple Registers	28
6.2.10. 23 (0x17) Read/Write Multiple Registers	29
6.2.11 Error Response	29
6.3 MODBUS Special Register Map	30
6.3.1 Adapter Identification Special Register (0x1000, 4096)	30
6.3.2 Adapter Watchdog Time, other Time Special Register (0x1020, 4128).....	31
6.3.3 Adapter Information Special Register (0x1100, 4352).....	31
6.3.4 Expansion Slot Information Special Resister (0x2000, 8192).....	33
6.4. MODBUS Reference.....	34
7. Troubleshooting.....	35
How to diagnose by LED indicator	35
How to diagnose when device couldn't communicate network	36
A.1 Product List	37
A.2. Glossary	37

1. Important Note

Solid state equipment has operational characteristics differing from those of electromechanical equipment. Safety Guidelines for the Application, Installation and Maintenance of Solid-State Controls describes some important differences between solid state equipment and hard-wired electromechanical devices.

Because of this difference, and also because of the wide variety of uses for solid state equipment, all persons responsible for applying this equipment must satisfy themselves that each intended application of this equipment is acceptable.

In no event will HITACHI be responsible or liable for indirect or consequential damages resulting from the use or application of this equipment.

The examples and diagrams in this manual are included solely for illustrative purposes. Because of the many variables and requirements associated with any installation, HITACHI cannot assume responsibility or liability for actual use based on the examples and diagrams.

Warning!

✓ **If you don't follow the directions, it could cause a personal injury, damage to the equipment or explosion**

- Do not assemble the products and wire with power applied to the system. Else it may cause an electric arc, which can result into unexpected and potentially dangerous action by field devices. Arching is explosion risk in hazardous locations. Be sure that the area is non-hazardous or remove system power appropriately before assembling or wiring the modules.
- Do not touch any terminal blocks or IO modules when system is running. Else it may cause the unit to an electric shock or malfunction.
- Keep away from the strange metallic materials not related to the unit and wiring works should be controlled by the electric expert engineer. Else it may cause the unit to a fire, electric shock or malfunction.



Caution!

✓ **If you disobey the instructions, there may be possibility of personal injury, damage to equipment or explosion. Please follow below Instructions.**

- Check the rated voltage and terminal array before wiring. Avoid the circumstances over 55°C of temperature. Avoid placing it directly in the sunlight.
- Avoid the place under circumstances over 85% of humidity.
- Do not place Modules near by the inflammable material. Else it may cause a fire.
- Do not permit any vibration approaching it directly.
- Go through module specification carefully, ensure inputs, output connections are made with the specifications. Use standard cables for wiring.
- Use Product under pollution degree 2 environment.

1.1. Safety Instruction

1.1.1. Symbols

<p>DANGER</p> 	<p>Information about practices or circumstances that can cause an explosion in a hazardous environment, which may lead to personal injury or death property damage, or economic loss.</p>
<p>IMPORTANT</p>	<p>Identifies information that is critical for successful application and understanding of the Product.</p>
<p>ATTENTION</p> 	<p>Identifies information about practices or circumstances that can lead to personal Injury, property damage, or economic loss. Attentions help you to identify a hazard, avoid a hazard, and recognize the consequences.</p>

1.1.2. Safety Notes

<p>DANGER</p> 	<p>The modules are equipped with electronic components that may be destroyed by electrostatic discharge. When handling the modules, ensure that the environment (persons, workplace and packing) is well grounded. Avoid touching conductive components, e.g. G-BUS Pin.</p>
--	--

1.1.3. Certification



2. Specification

2.1. Interface

2.1.1. RIO3-MBRL

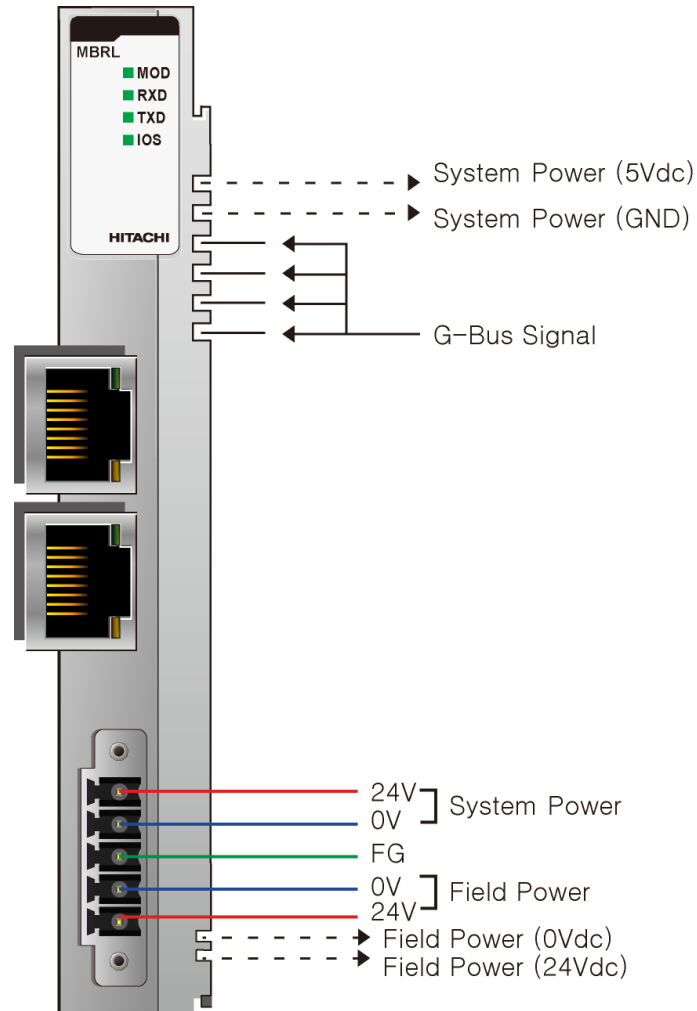

Pin No.	Signal Description
1	System Power, 24V
2	System Power, 24V
3	F.G
4	Field Power, Ground
5	Field Power, 24V

2.2. Specification

2.2.1. General Specification

General specification	
UL System Power	Supply voltage: 24Vdc nominal, Class 2
System Power	Supply voltage: 24Vdc nominal Supply voltage range: 15~28.8Vdc Reverse polarity protection
Power Dissipation	20mA typical @ 24Vdc
Current for I/O Module	1.0A @ 5Vdc
Isolation	System power to internal logic: Non-isolation System power I/O driver: Isolation
UL Field Power	Supply voltage: 24Vdc nominal, Class 2
Field Power	Supply voltage: 24Vdc typical * Field Power Range is different depending on IO Module series. Refer to IO Module`s Specification.
Max. Current Field Power Contact	DC 8A Max
Wiring	I/O Cable Max. 2.0mm ² (AWG14)
Torque	0.8Nm (7 lb-in)
Weight	77g
Module Size	22mm x 109mm x 70mm
Environmental specification	
Operating Temperature	- 20°C ~ 60 °C: 1.0A full load is allowed.
UL Temperature	- 20°C ~ 60 °C
Storage Temperature	- 40°C ~ 85 °C
Relative Humidity	5% ~ 90% non-condensing
Mounting	DIN rail

2.2.2. Interface Specification

Interface Specification RIO3-MBRL (RS-485)	
Adapter Type	Slave node (MODBUS Serial RTU/ASCII Server)
Protocol	MODBUS RTU and ASCII
Max. Expansion Module	16 slots
Max. Data Size (Input + Output)	Max. Input 256 bytes / Output 256 bytes
Max Length Bus Line	500m
Max. Nodes	8 nodes
Baud Rate	2400, 4800, 9600, 19200, 38400, 57600, 115200 bps
Interface Connector	RJ-45 socket * 2pcs
Settable Node Address	Via Dip switch
Indicator	4 LEDs 1 Green/Red, Module Status (MOD) 1 Green, Physical Connection (LINK) 1 Green, Exchange Data/Traffic Present (ACTIVE) 1 Green/Red, Expansion I/O Module Status (IOS)
Module Location	Starter module left side of RIO3 Series system
General specification	
Shock Operating	IEC 60068-2-27
Vibration Resistance	Based on IEC 60068-2-6
Industrial Emissions	EN 61000-6-4/A11 : 2011
Industrial Immunity	EN 61000-6-2 : 2005
Installation Position	Vertical and horizontal installation is available
Product Certifications	CE, UL, EAC

2.3. LED Indicator

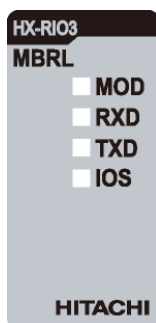

LED	LED Function / Description	LED Color
MOD	Module Status	Green/Red
RXD	Physical Connection	Green
TXD	Exchange Data/Traffic Present	Green
IOS	Expansion Module Status	Green/Red

2.3.1 MOD (Module Status LED)

Status	LED	To indicate
Not Powered	OFF	Power is not supplied to the unit.
Device Operational	Green	The unit is operating in normal condition.
Unrecoverable Fault	Red	The device has an unrecoverable fault. - Memory error or CPU watchdog error.

2.3.2 RXD (Receive Data LED)

Status	LED	To indicate
Not Powered or Not Linked	OFF	Device is idle or may not be powered.
Adapter received correct message frame	Green	Adapter (Slave) received correct frame which address to the slave or broadcast. About 20msec flashing

2.3.3 TXD (Transmit Data LED)

Status	LED	To indicate
Not Powered	OFF	Device is idle or may not be powered.
Adapter transmit frame	Flashing Green	Adapter (slave) transmit frame. About 20msec flashing.

2.3.4 IOS LED (Extension Module Status LED)

Status	LED	To indicate
Not Powered	OFF	Device may not be powered.
No Expansion Module	Flashing Red	Adapter has no expansion module
Internal Bus Connection, Run Exchanging I/O	Green	Exchanging I/O data.
Expansion Configuration Failed	Red	One or more expansion module occurred in fault state. <ul style="list-style-type: none"> - Detected invalid expansion module ID. - Overflowed Input /Output Size - Too many expansion module - Initialization failure - Communication failure. - Changed expansion module configuration. - Mismatch vendor code between adapter and expansion module.

3. Dimension

3.1. RIO3-MBRL

(mm)

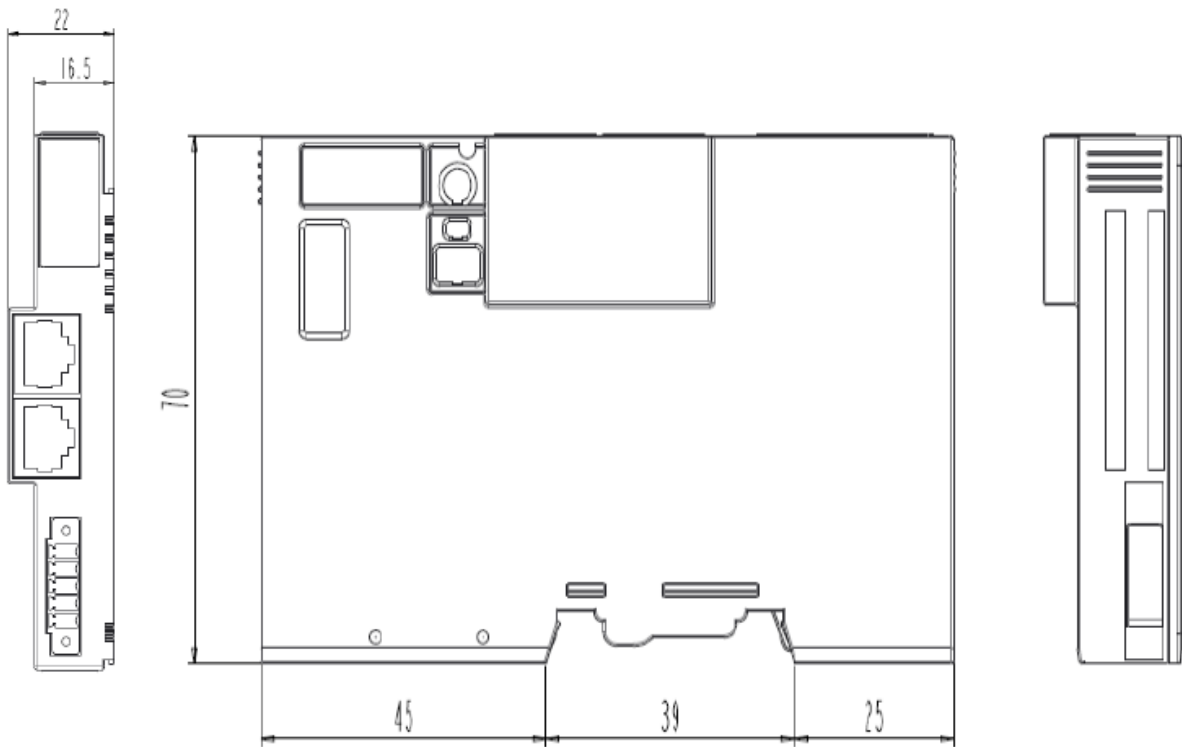

4. Mechanical Set Up

4.1. Total Expansion

The number of the module assembly that can be connected is 16. So the maximum length is 214mm
Exception.

4.2. Plugging and Removal of the Components



As above figure in order to safeguard the RIO3 module from jamming, it should be fixed onto the DIN rail with locking level. To do so, fold on the upper of the locking lever.

To pull out the RIO3 module, unfold the locking lever as below figure.

DANGER



Before work is done on the components, the voltage supply must be turned off.

5. MODBUS Electrical Interface

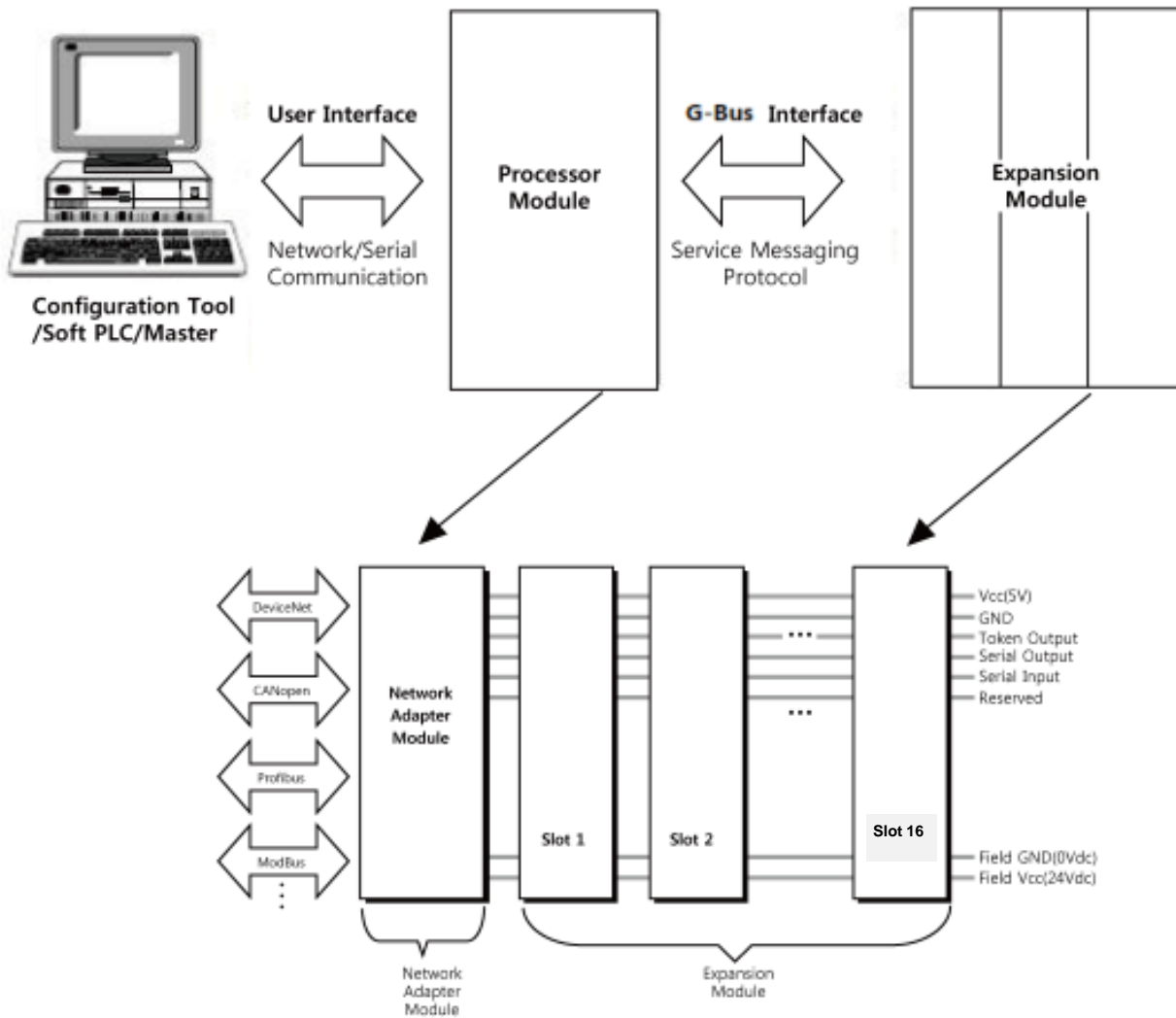

5.1. G-Bus System

- **Network Adapter Module**

The Network Adapter Module forms the link between the field bus and the field devices with the Expansion Modules.

The connection to different field bus systems can be established by each of the corresponding Network Adapter Module, e.g. for PROFIBUS, CAN open, Ethernet/IP, MODBUS/Serial, MODBUS/TCP etc.

- **Expansion Module**

The Expansion Modules are supported a variety of input and output field devices. There are digital and analog input/output modules and special function modules.

- **Two types of G-Bus Message**

- Service Messaging
- I/O Messaging

5.2 G-Bus Pin Description

Communication between the RIO3 series and the expansion module as well as system / field power supply of the bus modules is carried out via the internal bus. It is comprised of 6 data pin and 2 field power pins

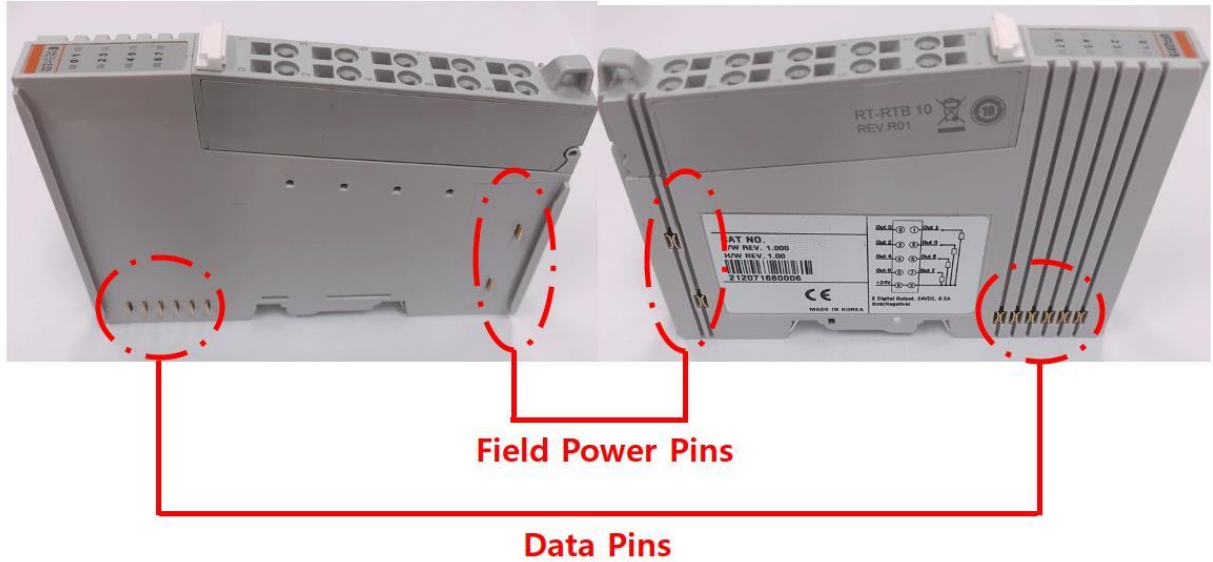

No.	Name	Description
1	Vcc	System supply voltage (5V dc).
2	GND	System Ground.
3	Token Output	Token output port of Processor module.
4	Serial Output	Transmitter output port of Processor module.
5	Serial Input	Receiver input port of Processor module.
6	Reserved	Reserved for bypass Token.
7	Field GND	Field Ground.
8	Field Vcc	Field supply voltage (24Vdc).

<p>DANGER</p> 	<p>Do not touch data and field power pins in order to avoid soiling and damage by ESD noise.</p>
--	--

5.3. RIO3-MBRL Electrical Interface

5.3.1. RJ-45 Socket

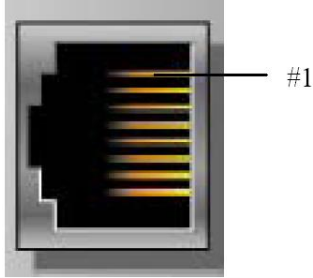

Shield RJ-45 Socket

RJ-45	Signal Name	Description
1	RS485 +	Transmit +
2	RS485 -	Transmit -
3	GND	Communication Ground
4	-	
5	-	
6	-	
7	-	
8	FG	Frame Ground
Case	Shield	

5.3.2. MODBUS Dip Switch Setup

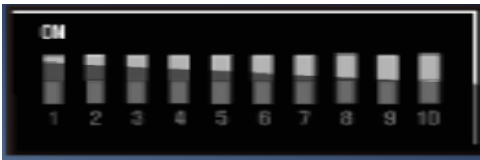

Item	Item setup	DIP Switch									
		#1	#2	#3	#4	#5	#6	#7	#8	#9	#10
Node ID	EEPROM value*	OFF	OFF	OFF							
	Node ID 1	ON	OFF	OFF							
	Node ID 7	ON	ON	ON							
Baud rate	115200bps				OFF	OFF	OFF				
	2400 bps				ON	OFF	OFF				
	4800 bps				OFF	ON	OFF				
	9600 bps				ON	ON	OFF				
	19200 bps				OFF	OFF	ON				
	38400 bps				ON	OFF	ON				
	57600 bps				OFF	ON	ON				
115200 bps				ON	ON	ON					
Byte Format	8bit, No Parity, 1Stop							OFF	OFF	OFF	
	8bit, Even Parity, 1Stop							ON	OFF	OFF	
	8bit, Odd Parity, 1Stop							OFF	ON	OFF	
	8bit, No Parity, 2Stop							ON	ON	OFF	
	7bit, Even Parity, 1Stop**							ON	OFF	ON	
	7bit, Odd Parity, 1Stop**							OFF	ON	ON	
	8bit, No Parity, 1Stop							ON	ON	ON	
RTU/ASCII Mode	RTU Mode										OFF
	ASCII Mode										ON

* Factory default value is 1.

** ASCII Mode is only available

5.3.3. Process Image Map

An expansion module may have 3 types of data as I/O data, configuration parameter and memory register. The data exchange between Network Adapter and expansion modules is done via an I/O process image data by RIO3 Series protocol. The following figure shows the data flow of process image between Network Adapter and expansion modules.

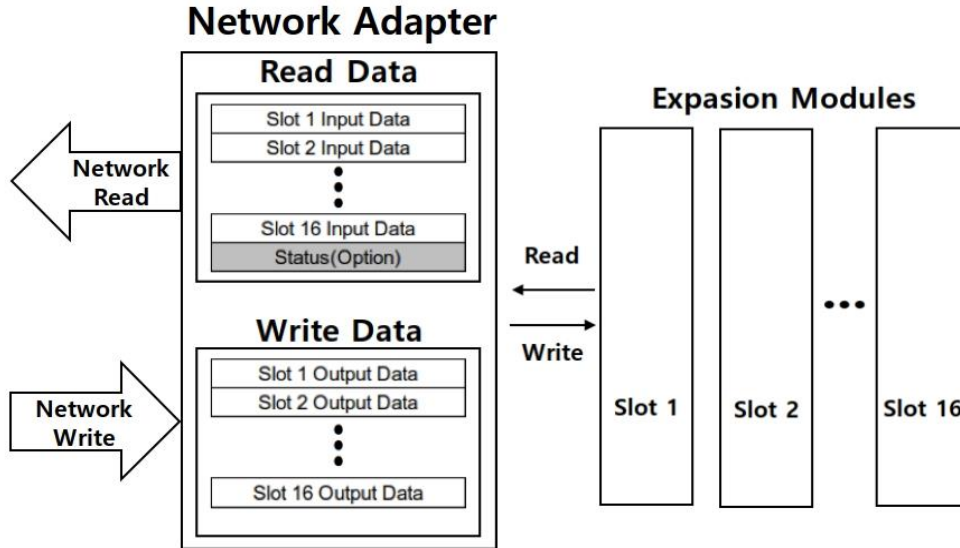

5.3.4. MODBUS Interface Register/Bit Map

• Register Map

Start Address	Read/Write	Description	Func. Code
0x0000 ~	Read	Process input image registers (Real Input Register)	3,4,23
0x0800 ~	Read/Write	Process output image registers (Real Output Register)	3,16,23
0x1000 *	Read	Adapter Identification special registers.	3,4,23
0x1020 *	Read/Write	Adapter Watchdog, other time special register.	3,4,6,16,23
0x1100 *	Read/Write	Adapter Information special registers.	3,4,6,16,23
0x2000 *	Read/Write	Expansion Slot Information special registers.	3,4,6,16,23

* The special register map must be accessed by read/write of each address (one address).

• Register Map

Start Address	Read/Write	Description	Func. Code
0x0000~	Read	Process input image bits All input registers area is addressable by bit address. Size of input image bit is size of input image register * 16.	2
0x1000~	Read/Write	Process output image bits All output registers area is addressable by bit address. Size of output image bit is size of output image register * 16.	1,5,15

5.4. Example

5.4.1. Example of Input Process Image (Input Register) Map

Input image data depends on slot position and expansion slot data type. Input process image data is only ordered by expansion slot position.

Example slot configuration

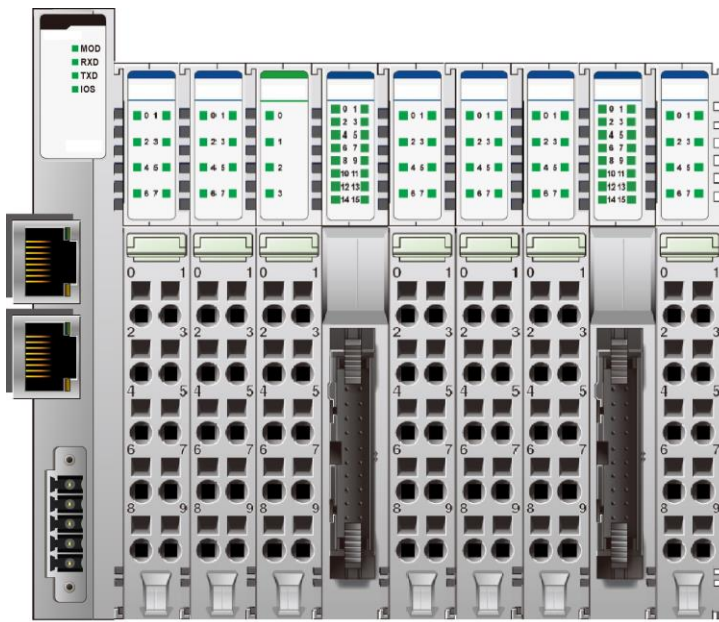

Slot Address	Module Description
#0	MODBUS RS485 Adapter
#1	8-discrete input
#2	8-discrete input
#3	4-analog input
#4	16-discrete input
#5	8-discrete input
#6	8-discrete input
#7	8-discrete input
#8	16-discrete input
#9	8-discrete input

Address	B15	B14	B13	B12	B11	B10	B9	B8	B7	B6	B5	B4	B3	B2	B1	B0
0x0001	Discrete Input 8 pts (Slot#2)								Discrete Input 8 pts (Slot#1)							
0x0002	Analog Input Ch0 high byte (Slot#3)								Analog Input Ch0 low byte (Slot#3)							
0x0003	Analog Input Ch1 high byte (Slot#3)								Analog Input Ch1 low byte (Slot#3)							
0x0004	Analog Input Ch2 high byte (Slot#3)								Analog Input Ch2 low byte (Slot#3)							
0x0005	Analog Input Ch3 high byte (Slot#3)								Analog Input Ch3 low byte (Slot#3)							
0x0006	Discrete Input 8 pts (Slot#4)								Discrete Input 8 pts (Slot#4)							
0x0007	Discrete Input 8 pts (Slot#6)								Discrete Input 8 pts (Slot#5)							
0x0008	Discrete Input 8 pts (Slot#8)								Discrete Input 8 pts (Slot#7)							
0x0009	Discrete Input 8 pts (Slot#9)								Discrete Input 8 pts (Slot#8)							

5.4.2. Example of Output Process Image (Output Register) Map

Output image data depends on slot position and expansion slot data type. Output process image data is only ordered by expansion slot position.

Example slot configuration

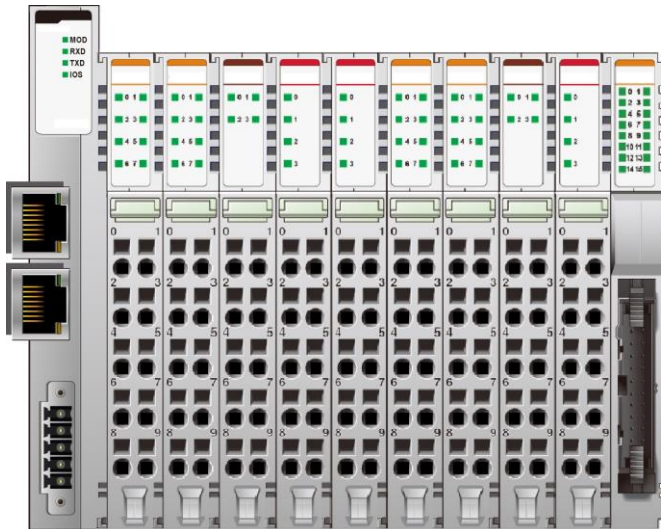

Slot Address	Module Description
#0	MODBUS RS485 Adapter
#1	8-discrete output
#2	8-discrete output
#3	4-analog output
#4	4-relay output
#5	4-relay output
#6	8-discrete output
#7	8-discrete output
#8	4-analog output
#9	4-relay output
#10	16-discrete output

Address	B15	B14	B13	B12	B11	B10	B9	B8	B7	B6	B5	B4	B3	B2	B1	B0
0x0800	Discrete Output 8 pts (Slot#2)							Discrete Input 8 pts (Slot#1)								
0x0801	Analog Output Ch0 high byte (Slot#3)							Analog Input Ch0 low byte (Slot#3)								
0x0802	Analog Output Ch1 high byte (Slot#3)							Analog Input Ch1 low byte (Slot#3)								
0x0803	Analog Output Ch2 high byte (Slot#3)							Analog Input Ch2 low byte (Slot#3)								
0x0804	Analog Output Ch3 high byte (Slot#3)							Analog Input Ch3 low byte (Slot#3)								
0x0805	Empty, Don't Care				Discrete Out 4 pts (Slot#5)			Empty, Don't Care				Discrete Out 4 pts (Slot#4)				
0x0806	Discrete Output low 8 pts (Slot#7)							Discrete Output low 8 pts (Slot#6)								
0x0807	Analog Output Ch0 high byte (Slot#8)							Analog Output Ch0 low byte (Slot#8)								
0x0808	Analog Output Ch1 high byte (Slot#8)							Analog Output Ch1 low byte (Slot#8)								
0x0809	Analog Output Ch2 high byte (Slot#8)							Analog Output Ch2 low byte (Slot#8)								
0x080A	Analog Output Ch3 high byte (Slot#8)							Analog Output Ch3 low byte (Slot#8)								
0x080B	Discrete Output low 8 pts (Slot#10)							Empty, Don't Care				Discrete Out 4 pts (Slot#9)				
0x080C	Empty, Don't Care							Discrete Output high 8 pts (Slot#10)								

6. MODBUS TCP/UDP INTERFACE

6.1 MODBUS TCP/ UDP Protocol

The MODBUS messaging service provides a Client/Server communication between devices connected on an Ethernet

TCP/IP network. All MODBUS/TCP messages are sent via TCP on registered port 502.

Refer to Modbus_Messaging_Implementation_Guide_V1_0a.pdf.

6.1.1. Comparison of MODBUS TCP/UDP and MODBUS/RTU

This header provides some differences compared to the MODBUS RTU application data unit used on serial line:

- The MODBUS 'slave address' field usually used on MODBUS Serial Line is replaced by a single byte 'Unit Identifier' within the MBAP Header. The 'Unit Identifier' is used to communicate via devices such as bridges, routers and gateways that use a single IP address to support multiple independent MODBUS end units.
- All MODBUS requests and responses are designed in such a way that the recipient can verify that a message is finished. For function codes where the MODBUS PDU has a fixed length, the function code alone is sufficient. For function codes carrying a variable amount of data in the request or response, the data field includes a byte count.
- When MODBUS is carried over TCP, additional length information is carried in the MBAP header to allow the recipient to recognize message boundaries even if the message has been split into multiple packets for transmission. The existence of explicit and implicit length rules and use of a CRC-32 error check code (on Ethernet) results in an infinitesimal chance of undetected corruption to a request or response message.

MODBUS TCP/ UDP

MBAP Header	Function	Data
7 chars	1 char	Up to 252 chars

MODBUS RTU

Start	Address	Function	Data	CRC Check	END
≥ 3.5 char	1 char	1 char	Up to 252 chars	2 chars	≥ 3.5 char

Function and data field of MODBUS/TCP are identical to function and data field of MODBUS/RTU.

6.1.2. MODBUS TCP/ UDP MBAP Header

The MBAP (MODBUS Application Protocol) header contains the following fields.

Fields	Length	Description	Client	Server
Transaction Identifier	2bytes	Identification of a MODBUS Request /Response transaction.	Initialized by the client	Recopied by the server from the received
Protocol Identifier	2bytes	0 = MODBUS protocol	Initialized by the client	Recopied by the server from the received
Length	2bytes	Number of following bytes	Initialized by the client (Request)	Initialized by the server (Response)
Unit Identifier	1byte	Identification of a remote slave connected on a serial line or on other buses.	Initialized by the client	Recopied by the server from the received

- Transaction Identifier - It is used for transaction pairing; the MODBUS server copies in the response the transaction identifier of the request.
- Protocol Identifier – It is used for intra-system multiplexing. The MODBUS protocol is identified by the value 0.
- Length - The length field is a byte count of the following fields, including the Unit Identifier and data fields.
- Unit Identifier – This field is used for intra-system routing purpose. Typically, MODBUS server must be returned with the same value set by MODBUS client.

6.2 Supported MODBUS Function Codes

Function Code	Function	Description
1(0x01)	Read Coils	Read output bit
2(0x02)	Read Discrete Inputs	Read input bit
3(0x03)	Read Holding Registers	Read output word
4(0x04)	Read Input Registers	Read input word
5(0x05)	Write Single Coil	Write one-bit output
6(0x06)	Write Single Register	Write one-word output
8(0x08)	Diagnostics	Read diagnostic register
15(0x0F)	Write Multiple Coils	Write a number of output bits
16(0x10)	Write Multiple registers	Write a number of output words
23(0x17)	Read/Write Multiple registers	Read a number of input words /Write a number of output words

- Refer to MODBUS APPLICATION PROTOCOL SPECIFICATION V1.1a

6.2.1. 1(0x01) Read Coils

This function code is used to read from 1 to 2000 contiguous status of coils in a remote device. The Request PDU specifies the starting address, i.e. the address of the first coil specified, and the number of coils. In the PDU Coils are addressed starting at zero. Therefore, coils numbered 1-16 are addressed as 0-15. The coils in the response message are packed as one coil per bit of the data field. Status is indicated as 1= ON and 0= OFF.

• Request

Field name	Example
Function Code	0x01
Starting Address Hi	0x10
Starting Address Lo	0x00
Quantity of Outputs Hi	0x00
Quantity of Outputs Lo	0x0A

• Response

Field name	Example
Function Code	0x01
Byte Count	0x02
Output Status	0x55
Output Status	0x02

- In case of address 0x1015~0x1000 output bit value: 10101010_01010101.

6.2.2. 2(0x02) Read Discrete Inputs

This function code is used to read from 1 to 2000 contiguous status of discrete inputs in a remote device. The Request PDU specifies the starting address, i.e. the address of the first input specified, and the number of inputs. In the PDU Discrete Inputs are addressed starting at zero. Therefore, Discrete inputs numbered 1-16 are addressed as 0-15. The discrete inputs in the response message are packed as one input per bit of the data field. Status is indicated as 1= ON; 0= OFF.

• Request

Field name	Example
Function Code	0x02
Starting Address Hi	0x00
Starting Address Lo	0x00
Quantity of Inputs Hi	0x00
Quantity of Inputs Lo	0x0A

• Response

Field name	Example
Function Code	0x02
Byte Count	0x02
Output Status	0x80
Output Status	0x00

- In case of address 0x0015~0x0000 input bit value: 00000000_10000000.

6.2.3. 3(0x03) Read Holding Registers

This function code is used to read the contents of a contiguous block of holding registers in a remote device. The Request PDU specifies the starting register address and the number of registers. The register data in the response message are packed as two bytes per register, with the binary contents right justified within each byte. For each register, the first byte contains the high order bits and the second contains the low order bits

• Request

Field name	Example
Function Code	0x02
Starting Address Hi	0x00
Starting Address Lo	0x00
Quantity of Inputs Hi	0x00
Quantity of Inputs Lo	0x0A

• Response

Field name	Example
Function Code	0x02
Byte Count	0x02
Output Status	0x80
Output Status	0x00

- In case of address 0x0800, 0x0801 output register value: 0x1122, 0x3344.

6.2.4. 4 (0x04) Read Input Registers

This function code is used to read from 1 to approx. 125 contiguous input registers in a remote device. The Request PDU specifies the starting register address and the number of registers. The register data in the response message are packed as two bytes per register, with the binary contents right justified within each byte. For each register, the first byte contains the high order bits and the second contains the low order bits. This function code is used to read from 1 to approx. 125 contiguous input registers in a remote device. The Request PDU specifies the starting register address and the number of registers. The register data in the response message are packed as two bytes per register, with the binary contents right justified within each byte. For each register, the first byte contains the high order bits and the second contains the low order bits.

• Request

Field name	Example
Function Code	0x04
Starting Address Hi	0x00
Starting Address Lo	0x00
Quantity of Resister Hi	0x00
Quantity of Resister Lo	0x02

• Response

Field name	Example
Function Code	0x03
Byte Count	0x04
Input Register#0 Hi	0x00
Input Register#0 Lo	0x80
Input Register#1 Hi	0x00
Input Register#1 Lo	0x00

- In case of address 0x0000, 0x0001 input register value: 0x0080, 0x0000.

6.2.5. 5 (0x05) Write Single Coil

This function code is used to write a single output to either ON or OFF in a remote device. The requested ON/OFF state is specified by a constant in the request data field. A value of FF 00 hex requests the output to be ON. A value of 00 00 requests it to be OFF. All other values are illegal and will not affect the output.

• Request

Field name	Example
Function Code	0x05
Output Address Hi	0x10
Output Address Lo	0x01
Output Value Hi	0xFF
Output Value Lo	0x00

• Response

Field name	Example
Function Code	0x05
Output Address Hi	0x10
Output Address Lo	0x01
Output Value Hi	0xFF
Output Value Lo	0x00

- Output bit of address 0x1001 turns ON.

6.2.6. 6 (0x06) Write Single Register

This function code is used to write a single holding register in a remote device. Therefore, register numbered 1 is addressed as 0. The normal response is an echo of the request, returned after the register contents have been written.

• Request

Field name	Example
Function Code	0x06
Register Address Hi	0x08
Register Address Lo	0x00
Register Value Hi	0x11
Register Value Lo	0x22

• Response

Field name	Example
Function Code	0x06
Register Address Hi	0x08
Register Address Lo	0x00
Register Value Hi	0x11
Register Value Lo	0x22

- In case of address 0x0800 output register value: 0x0000 changes to 0x1122.

6.2.7. 8 (0x08) Diagnostics

MODBUS function code 08 provides a series of tests for checking the communication system between a client (Master) device and a server (Slave), or for checking various internal error conditions within a server. The function uses a two-byte sub-function code field in the query to define the type of test to be performed. The server echoes both the function code and sub-function code in a normal response. Some of the diagnostics cause data to be returned from the remote device in the data field of a normal response.

• Request

Field name	Example
Function Code	0x08
Sub-Function Hi	0x00
Sub-Function Lo	0x00
Data Hi	0x11
Data Lo	0x22

• Response

Field name	Example
Function Code	0x08
Sub-Function Hi	0x00
Sub-Function Lo	0x00
Data Hi	0x11
Data Lo	0x22

The data passed in the request data field is to be returned (looped back) in the response.
The entire response message should be identical to the request.

Sub-function	Data Field (Request)	Data Field (Response)	Description
0x0000(0)	Any	Echo Request Data	

Sub-function 0x0001(1) Restart Communications Option

The remote device could be initialized and restarted, and all its communications event counters are cleared. Especially, data field 0x55AA make the remote device to restart with factory default setup of EEPROM.

Sub-function	Data Field (Request)	Data Field (Response)	Description
0x0001(1)	0x0000 or 0xFF00	Echo Request Data	Reset
0x0001(1)	0x55AA+0xAB7B+Sumcheck	Echo Request Data	Reset with Factory default ¹⁾
0x0001(1)	0x55AA+0xAA55+Sumcheck	Echo Request Data	Reset with Factory default ²⁾

1) Watchdog time value, auto recovery will be the factory defaults value.

2) Mac Address, IP Address, Subnet Mask Address, Gateway Address will be the factory default value.

Sub-function 0x000A (10) Clear Counters and Diagnostic Register

The goal is to clear all counters and the diagnostic register. Counters are also cleared upon power-up.

Sub-function	Data Field (Request)	Data Field (Response)	Description
0x000A(10)	0x0000	Echo Request Data	

Sub-function 0x000B (11) Return Bus Message Count

The response data field returns the quantity of messages that the remote device has detected on the communications system since its last restart, clear counters operation, or power-up.

Sub-function	Data Field (Request)	Data Field (Response)	Description
0x000B(11)	0x0000	Total Message Count	

Sub-function 0x000C (12) Return Bus Communication Error Count

The response data field returns the quantity of CRC errors encountered by the remote device since its last restart, clear counters operation, or power-up.

Sub-function	Data Field (Request)	Data Field (Response)	Description
0x000C(12)	0x0000	CRC Error Count	

Sub-function 0x000D (13) Return Bus Exception Error Count

The response data field returns the quantity of MODBUS exception responses returned by the remote device since its last restart, clear counters operation, or power-up.

Exception responses are described and listed in section 6.2.11.

Sub-function	Data Field (Request)	Data Field (Response)	Description
0x000D(13)	0x0000	Exception Error Count	

Sub-function 0x000E (14) Return Slave Message Count

The response data field returns the quantity of messages addressed to the remote device, or broadcast, that the remote device has processed since its last restart, clear counters operation, or power-up.

Sub-function	Data Field (Request)	Data Field (Response)	Description
0x000E(14)	0x0000	Slave Message Count	

Sub-function 0x000F (15) Return Slave No Response Count

The response data field returns the quantity of messages addressed to the remote device for which it has returned no response (neither a normal response nor an exception response), since its last restart, clear counters operation, or power-up.

Sub-function	Data Field (Request)	Data Field (Response)	Description
0x000F(15)	0x0000	Slave No Response Count	

Sub-function 0x0064 (100) Return Slave ModBus, Internal Bus Status

The response data field returns the status of ModBus and Internal Bus addressed to the remote device. This status values are identical with status 1word of input process image.

Sub-function	Data Field (Request)	Data Field (Response)	Description
0x0064(100)	0x0000	ModBus, Internal Bus Status	Same as status 1word

Sub-function 0x0065 (101) Return Slave Watchdog Error Count

The response data field returns the quantity of watchdog error addressed to the remote device since its last restart, clear counters operation, or power-up.

Sub-function	Data Field (Request)	Data Field (Response)	Description
0x0065(101)	0x0000	Watchdog Error Count	

6.2.8. 15 (0x0F) Write Multiple Coils

This function code is used to force each coil in a sequence of coils to either ON or OFF in a remote device. The Request PDU specifies the coil references to be forced. Coils are addressed starting at zero. A logical '1' in a bit position of the field requests the corresponding output to be ON. A logical '0' requests it to be OFF. The normal response returns the function code, starting address, and quantity of coils forced

• Request

Field name	Example
Function Code	0x0F
Starting Address Hi	0x10
Starting Address Lo	0x00
Quantity of Outputs Hi	0x00
Quantity of Outputs Lo	0x0A
Byte Count	0x02
Output Value#0	0x55
Output Value#1	0x01

• Response

Field name	Example
Function Code	0x0F
Starting Address Hi	0x10
Starting Address Lo	0x00
Quantity of Outputs Hi	0x00
Quantity of Outputs Lo	0x0A

-In case of address 0x1015~0x1000 output bit value: 00000000_00000000 changes to 00000001_01010101.

6.2.9. 16 (0x10) Read/Write Multiple Registers

This function code is used to write a block of contiguous registers (1 to approx. 120 registers) in a remote device. The requested written values are specified in the request data field. Data is packed as two bytes per register. The normal response returns the function code, starting address, and quantity of registers written.

• Request

Field name	Example
Function Code	0x0F
Starting Address Hi	0x10
Starting Address Lo	0x08
Quantity of Registers Hi	0x00
Quantity of Registers Lo	0x02
Byte Count	0x04
Register Value#0 Hi	0x11
Register Value#0 Lo	0x22
Register Value#1 Hi	0x33
Register Value#1 Lo	0x44

• Response

Field name	Example
Function Code	0x0F
Starting Address Hi	0x10
Starting Address Lo	0x08
Quantity of Registers Hi	0x00
Quantity of Registers Lo	0x02

-In case of address 0x0800, 0x0801 output register value: 0x0000, 0x0000 changes to 0x1122, 0x3344.

6.2.10. 23 (0x17) Read/Write Multiple Registers

This function code performs a combination of one read operation, and one write operation in a single MODBUS transaction. The write operation is performed before the read. The request specifies the starting address and number of holding registers to be read as well as the starting address, number of holding registers, and the data to be written. The byte count specifies the number of bytes to follow in the write data field. The normal response contains the data from the group of registers that were read. The byte count field specifies the quantity of bytes to follow in the read data field.

• Request

Field name	Example
Function Code	0x17
Read Starting Address Hi	0x08
Read Starting Address Lo	0x00
Quantity of Read Hi	0x00
Quantity of Read Lo	0x02
Write Starting Address Hi	0x08
Write Starting Address Lo	0x00
Quantity of Write Hi	0x00
Quantity of Write Lo	0x02
Byte Count	0x04
Write Reg. Value#0 Hi	0x11
Write Reg. Value#0 Lo	0x22
Write Reg. Value#1 Hi	0x33
Write Reg. Value#1 Lo	0x44

• Response

Field name	Example
Function Code	0x0F
Byte Count	0x04
Read Reg. Value#0 Hi	0x11
Read Reg. Value#0 Lo	0x22
Read Reg. Value#1 Hi	0x33
Read Reg. Value#1 Lo	0x44

- In case of address 0x0800, 0x0801 output register value: 0x0000, 0x0000 changes to 0x1122, 0x3344.

6.2.11 Error Response

In an exception response, the server sets the MSB of the function code to 1. This makes the function code value in an exception response exactly 80 hexadecimal higher than the value would be for a normal response.

•Exception Response Example

Field name	Example
Function Code	0x81
Exception Code	0x02

•Exception Codes

Exception Code	Name	Description
01	Illegal Function	The function code received in the query is not an allowable action for the server (or slave).
02	Illegal Data Address	The data address received in the query is not an allowable address for the server (or slave).
03	Illegal Data Value	A value contained in the query data field is not an allowable value for server (or slave).
04	Slave Device Failure	An unrecoverable error occurred while the server (or slave) was attempting to perform the requested action.
05	Acknowledge	The server (or slave) has accepted the request and is processing it, but a long duration of time will be required to do so.
06	Slave Device Busy	Specialized use in conjunction with programming commands. The server (or slave) is engaged in processing a long-duration program command. The client (or master) should retransmit the message later when the server (or slave) is free.
08	Memory Parity Error	The server (or slave) attempted to read record file, but detected a parity error in the memory. The client (or master) can retry the request, but service may be required on the server (or slave) device.
0A	Gateway Unavailable Path	Specialized use in conjunction with gateways, indicates that the gateway was unable to allocate an internal communication path from the input port to the output port for processing the request.

- RIO3-MBRL response exception code 01, 02, 03, 04 and 06.

6.3 MODBUS Special Register Map

The special register map can be accessed by function code 3, 4, 6 and 16. Also the special register map must be accessed by read/write of each address (one address).

6.3.1 Adapter Identification Special Register (0x1000, 4096)

Address	Access	Type, Size	Description
0x1000(4096)	Read	1word	Vendor ID = 0x02E5 (741), HITACHI
0x1001(4097)	Read	1word	Device type = 0x000C, Network Adapter
0x1002(4098)	Read	1word	Product Code = 0x91A0
0x1003(4099)	Read	1word	Firmware revision, if 0x0101, revision 1.01
0x1004(4100)	Read	2word	Product unique serial number
0x1005(4101)	Read	String up to 18byte	Product name string (ASCII) "RIO3-MBRL, Modbus/485 Adapter, GBUS"
0x1006(4102)	Read	1word	Sum check of EEPROM
0x1010(4112)	Read	2word	Firmware release date
0x1011(4113)	Read	2word	Product manufacturing inspection date
0x101E(4126)	Read	7word - 1word - 1word - 1word - 1word - 1word - 2word	Composite Id of following address * RTU mode 0x1100(4352), MSB: Modbus RS485 Node. LSB : RS232 Node 0x1000(4096), Vendor ID 0x1001(4097), Device type 0x1002(4098), Product code 0x1003(4099), Firmware revision 0x1004(4100), Product serial number

- String Type consists of valid string length (first 1word) and array of characters

6.3.2 Adapter Watchdog Time, other Time Special Register (0x1020, 4128)

A watchdog timer can be configured for timeout periods up to 65535(1unit=100msec). The Watchdog timer will timeout (timer decreased, reached 0) if ModBus operation to the slave node does not occur over the configured watchdog value, then the slave adapter forces that slot output value is automatically set to user-configured fault actions and values.

Address	Access	Type, Size	Description
0x1020(4128)	Read/Write	1word	Watchdog time value 16bit unsigned. The time value is represented by multiples of 100msec. The 0 (watchdog timeout disabled) is default value. A changing of watchdog time value resets watchdog error and counter.
0x1021(4129)	Read	1word	Watchdog timer remain value This value is decreased every 100msec
0x1022(4130)	Read	1word	Watchdog error counter, it is cleared by writing address 0x1020
0x1023(4131)	Read/Write	1word	Enable/disable auto recovery Watchdog error when receiving new frame. 0: Disable, 1:Enable(default). Its value is stored in EEPROM
0x1028(4136)	Read	1word	IO update time, main loop time. (1usec unit)

6.3.3 Adapter Information Special Register (0x1100, 4352)

Address	Access	Type, Size	Description								
0x1100(4352)	Read/Write	1word	Node address - MSB : Modbus RS485 Node. LSB : RS232 Node(Fixed 1).								
0x1102(4354)	Read	1word	Start address of input image word register. =0x0000								
0x1103(4355)	Read	1word	Start address of output image word register. =0x0800								
0x1104(4356)	Read	1word	Size of input image word register.								
0x1105(4357)	Read	1word	Size of output image word register.								
0x1106(4358)	Read	1word	Start address of input image bit. = 0x0000								
0x1107(4359)	Read	1word	Start address of output image bit. =0x1000								
0x1108(4360)	Read	1word	Size of input image bit.								
0x1109(4361)	Read	1word	Size of output image bit.								
0x110A(4362)	Read	1word	Update time for cyclic data change (same as 0x1028)								
0x110D(4365)	Read	1word	Current Dip Switch State.								
0x110E(4366)	Read	up to 33word	Expansion slot's GT-number including GL First 1word is adapter's number, if RIO3-MBRL, then 0x9073								
0x1110(4368)	Read	1word	Number of expansion slot								
0x1113(4371)	Read	up to 33word	Expansion slot Module Id. Refer to Appendix A.1 Product List. First 1word is adapter's module id.								
0x1119(4377)	Read	1word	Hi byte is Modbus status; low byte is internal status. Zero value means 'no error'.								
			<table border="1"> <thead> <tr> <th>Modbus status</th> <th>Internal bus status(G-Bus)</th> </tr> </thead> <tbody> <tr> <td>0X00 :No Error</td> <td>0X00 : OPERATING</td> </tr> <tr> <td>0X01: ERR_DIP_SWITCH</td> <td>0X01 : COMMUNICATION_FAULT</td> </tr> <tr> <td>0X40:ERR_CRC_LRC</td> <td></td> </tr> </tbody> </table>	Modbus status	Internal bus status(G-Bus)	0X00 :No Error	0X00 : OPERATING	0X01: ERR_DIP_SWITCH	0X01 : COMMUNICATION_FAULT	0X40:ERR_CRC_LRC	
			Modbus status	Internal bus status(G-Bus)							
0X00 :No Error	0X00 : OPERATING										
0X01: ERR_DIP_SWITCH	0X01 : COMMUNICATION_FAULT										
0X40:ERR_CRC_LRC											

			0X80: ERR_WATCHDOG	0X02 : CONNECT_FAULT 0X03 : CONFIG_FAULT 0X04: NO_EXPANSION 0X05: INVALID_ATTR_VALUE 0X06: TOO_MUCH_DATA 0X07: VENDOR_ERROR 0X08: NOT_EXPECTED_SLOT 0X09: CRC_ERROR
0x111D(4381)	Read	1word	Adapter RIO3 Series Revision.	

* After the system is reset, the new "Set Value" action is applied.

** If the slot location is changed, set default value automatically (all expansion slot are live).

6.3.4 Expansion Slot Information Special Resister (0x2000, 8192)

Each expansion slot has 0x20(32) address offset and same information structure.

Slot#1 0x2000(8192)~0x201F(8223)	Slot#2 0x2020(8224)~0x203F(8255)
Slot#3 0x2040(8256)~0x205F(8287)	Slot#4 0x2060(8288)~0x207F(8319)
Slot#5 0x2080(8320)~0x209F(8351)	Slot#6 0x20A0(8352)~0x20BF(8383)
Slot#7 0x20C0(8384)~0x20DF(8415)	Slot#8 0x20E0(8416)~0x20FF(8447)
Slot#9 0x2100(8448)~0x211F(8479)	Slot#10 0x2120(8480)~0x213F(8511)
Slot#11 0x2140(8512)~0x215F(8543)	Slot#12 0x2160(8544)~0x217F(8575)
Slot#13 0x2180(8576)~0x219F(8607)	Slot#14 0x21A0(8608)~0x21BF(8639)
Slot#15 0x21C0(8640)~0x21DF(8671)	Slot#16 0x21E0(8672)~0x21FF(8703)

Address Offset	Expansion Slot#1	Expansion Slot#2	Expansion Slot#3	Expansion Slot#4	Expansion Slot#16
+ 0x00(+0)	0x2000(8192)	0x2020(8224)	0x2040(8256)	0x2060(8288)	0x21E0(8672)
+ 0x01(+1)	0x2001(8193)	0x2021(8225)	0x2041(8257)	0x2061(8289)	0x21E1(8673)
+ 0x02(+2)	0x2002(8194)	0x2022(8226)	0x2042(8258)	0x2062(8290)	0x21E2(8674)
+ 0x03(+3)	0x2003(8195)	0x2023(8227)	0x2043(8259)	0x2063(8291)	0x21E3(8675)
+ 0x04(+4)	0x2004(8196)	0x2024(8228)	0x2044(8260)	0x2064(8292)	0x21E4(8676)
+ 0x05(+5)	0x2005(8197)	0x2025(8229)	0x2045(8261)	0x2065(8293)	0x21E5(8677)
+ 0x06(+6)	0x2006(8198)	0x2026(8230)	0x2046(8262)	0x2066(8294)	0x21E6(8678)
+ 0x07(+7)	0x2007(8199)	0x2027(8231)	0x2047(8263)	0x2067(8295)	0x21E7(8679)
+ 0x08(+8)	0x2008(8200)	0x2028(8232)	0x2048(8264)	0x2068(8296)	0x21E8(8680)
+ 0x09(+9)	0x2009(8201)	0x2029(8233)	0x2049(8265)	0x2069(8297)	0x21E9(8681)
+ 0x0A(+10)	0x200A(8202)	0x202A(8234)	0x204A(8266)	0x206A(8298)	0x21EA(8682)
+ 0x0B(+11)	0x200B(8203)	0x202B(8235)	0x204B(8267)	0x206B(8299)	0x21EB(8683)
+ 0x0C(+12)	0x200C(8204)	0x202C(8236)	0x204C(8268)	0x206C(8300)	0x21EC(8684)
+ 0x0D(+13)	0x200D(8205)	0x202D(8237)	0x204D(8269)	0x206D(8301)	0x21ED(8685)
+ 0x0E(+14)	0x200E(8206)	0x202E(8238)	0x204E(8270)	0x206E(8302)	0x21EE(8686)
+ 0x0F(+15)	0x200F(8207)	0x202F(8239)	0x204F(8271)	0x206F(8303)	0x21EF(8687)
+ 0x10(+16)	0x2010(8208)	0x2030(8240)	0x2050(8272)	0x2070(8304)	0x21E0(8688)
+ 0x11(+17)	0x2011(8209)	0x2031(8241)	0x2051(8273)	0x2071(8305)	0x21E1(8689)
+ 0x12(+18)	0x2012(8210)	0x2032(8242)	0x2052(8274)	0x2072(8306)	0x21E2(8690)
+ 0x13(+19)	0x2013(8211)	0x2033(8243)	0x2053(8275)	0x2073(8307)	0x21E3(8691)
+ 0x14(+20)	0x2014(8212)	0x2034(8244)	0x2054(8276)	0x2074(8308)	0x21E4(8692)
+ 0x15(+21)	0x2015(8213)	0x2035(8245)	0x2055(8277)	0x2075(8309)	0x21E5(8693)
+ 0x16(+22)	0x2016(8214)	0x2036(8246)	0x2056(8278)	0x2076(8310)	0x21E6(8694)
+ 0x17(+23)	0x2017(8215)	0x2037(8247)	0x2057(8279)	0x2077(8311)	0x21E7(8695)
+ 0x18(+24)	0x2018(8216)	0x2038(8248)	0x2058(8280)	0x2078(8312)	0x21E8(8696)
+ 0x19(+25)	0x2019(8217)	0x2039(8249)	0x2059(8281)	0x2079(8313)	0x21E9(8697)
+ 0x1A(+26)	0x201A(8218)	0x203A(8250)	0x205A(8282)	0x207A(8314)	0x21EA(8698)
+ 0x1B(+27)	0x201B(8219)	0x203B(8251)	0x205B(8283)	0x207B(8315)	0x21EB(8699)
+ 0x1C(+28)	0x201C(8220)	0x203C(8252)	0x205C(8284)	0x207C(8316)	0x21EC(8700)
+ 0x1D(+29)	0x201D(8221)	0x203D(8253)	0x205D(8285)	0x207D(8317)	0x21ED(8701)
+ 0x1E(+30)	0x201E(8222)	0x203E(8254)	0x205E(8286)	0x207E(8318)	0x21EE(8702)
+ 0x1F(+31)	0x201F(8223)	0x203F(8255)	0x205F(8287)	0x207F(8319)	0x21EF(8703)

Address Offset	Access	Type, Size	Description
----------------	--------	------------	-------------

+ 0x02(+2) **	Read	1word	Input start register address of input image word this slot.
+ 0x03(+3) **	Read	1word	Input word's bit offset of input image word this slot.
+ 0x04(+4) **	Read	1word	Output start register address of output image word this slot.
+ 0x05(+5) **	Read	1word	Output word's bit offset of output image word this slot.
+ 0x06(+6) **	Read	1word	Input bit start address of input image bit this slot.
+ 0x07(+7) **	Read	1word	Output bit start address of output image bit this slot.
+ 0x08(+8) **	Read	1word	Size of input bit this slot
+ 0x09(+9) **	Read	1word	Size of output bit this slot
+ 0x0A(+10)**	Read	n words	Read input data this slot
+ 0x0B(+11)**	Read/Write	n words	Read/write output data this slot
+ 0x0E(+14)	Read	1word	GT-number, if GT-1238, returns 0x1238
+ 0x0F(+15)	Read	String upto 72bytes	First 1word is length of valid character string. If GT-1238, returns "00 1E 52 54 2D 31 32 33 38 2C 20 38 44 49 2C 20 32 34 56 64 63 2C 20 55 6E 69 76 65 72 73 61 6C 00 00" Valid character size = 0x001E =30 characters, "GT-1238, 8DI, 24Vdc, Universal"
+ 0x10(+16)	Read	1word	Size of configuration parameter byte
+ 0x11(+17)**	Read/Write	n words	Read/write Configuration parameter data, Refer to each IO parameter Specification.
+ 0x17(+23)	Read	2words	Firmware Revision ex) 0x00010010 (Major revision 1 /Minor revision 1, Rev 1.001)
+ 0x19(+25)	Read	2words	Firmware release date.

* After the system is reset, the new "Set Value" action is applied.

** Nothing of output, input, memory or configuration parameter corresponding slot returns Exception 02.

6.4. MODBUS Reference

MODBUS Reference Documents

<http://www.modbus.org>

MODBUS Tools

<http://www.modbustools.com>, modbus poll

<http://www.win-tech.com>, modscan32

7. Troubleshooting

How to diagnose by LED indicator

LED Status	Cause	Action
All LED turns off	- No power	- Check main power Cable
	- System power is not supplied.	- Contact Sales team and send module for repair.
MOD LED flashes green	- Failure of initialization EEPROM parameter.	- Contact Sales team and send module for repair.
MOD LED flashes red	- Excess of expansion slot - Excess of IO size - Wrong IO composition - Occurrence of EEPROM checksum error	- Use expansion slot up to 32. - Compose that IO total size is not excess. - Check composition I/O Module
MOD LED is red	- Wrong address ID - Occurrence critical error in firmware	- Contact Sales team and send module for repair.
I/O LED turns off	- Failure of realization expansion Module - No expansion Module	- Check connector status both NA series and expansion module.
I/O LED flashes red	Failure of configuration baud rate	- Check communication cable with Master - Check power for master.
	Failure of initialization I/O	- Use expansion slot up to 32. - Compose that I/O total size is not excess.
		NA series notice unidentified expansion module ID. Check status of expansion module.
I/O LED is red	Failure of exchanging I/O data	Check status of expansion I/O connection.
NET LED turns off	Failure of communication with Master	Check main power for master and communication cable.
NET LED flashed green	Failure of exchanging data with master	Check status in software for Master configuration.
NET LED is red	Communication connecting lost	Check BUS line cable for connection with master.
		Check duplication address.

How to diagnose when device couldn't communicate network

Inspection of wrong or omission cable connection.

- Check status of cable connection for each node.
- Check that all colour matches between connector and cable.
- Check wire omission.

Configuration of Node address

- Check duplication node address.

Configuration of Master

- Check configuration of master
- Check whether to do download or don't
- Check composition is right
 - Configuration of communication baud rate
 - I/O size
 - Configuration of each node

Ground and environment

- Check ground is contacted
- Check environment factor (temperature, humidity, etc.) is in less than regular limit

APPENDIX A

A.1 Product List

Please refer the separate HX-RIO3 product list document

A.2. Glossary

- System Power: The power for starting up CPU.
- Field Power: The power for input and output line.
- EDS: Electronic Data Sheet.
- Sink: The method of in/output power supply if a device has no power source.
- Source: The method of in/output power supply if a device has the power source.