

OPTIDRIVE™ coolvert



**DESIGNED FOR
ROTARY & SCROLL
COMPRESSOR
CONTROL**

7 – 20A 200V Single Phase Input
14 – 75A 400V Three Phase Input



SPECIFICALLY DESIGNED FOR MACHINE BUILDERS TO OPTIMISE THE PERFORMANCE OF ROTARY AND SCROLL COMPRESSORS



Motor Technology & Safety

Accurate starting torque to ensure hermetic BLDC / PM Rotary and Scroll compressors start smoothly under all operating conditions.

Configurable start-up profile with independent acceleration ramps to precisely match the compressor manufacturers requirements.

Integrated high-performance EMC (Electro-Magnetic Compatibility) filters provide C2 compliance for conducted emissions and C1 compliance with optional external filter.

Save Energy

Improved system performance (COP) by modulating the compressor speed to match the cooling demand.

Suction pressure set-point control carried out by the application controller or directly in the drive. This matches the speed of the compressor to the system demand reducing the error around the set-point (under/over shoot) in the evaporator, saves 4% energy per 1-degree Kelvin difference.

Rotary & Scroll compressors provide a wide operating range, typically 20 rps (1200 rpm) to 120 rps (7200 rpm). This means that the compressor can operate at very low speed, when cooling demand is low, resulting in fewer compressor start stops.

Reduced Maintenance Costs

Extended speed range means less stop-starts, providing longer compressor life.

Soft starting reduces the mechanical stress at compressor start up, which extends compressor life.

THE OBVIOUS CHOICE...



-20 to +60C ambient temperature rating



Locked Rotor Protection (Class B software)



Through panel mounting solution



Modbus RTU onboard



Coldplate solution



Oil Return Feature

TYPICAL APPLICATIONS INCLUDE



Condensing Units



Heat Pumps



Refrigerated display cases



Chillers



Start up sequence with independent ramps



Minimum on/off times for compressor protection



Compressor demagnetization protection



Crankcase Heating built-in



STO to SIL3 independently certified



60730 certified – Class B software for compressor overload, locked rotor with input and output phase loss protection



APPROVED FOR USE WITH THE FOLLOWING REFRIGERANTS:

A2L Lightly flammable
A3 Highly flammable



PRECISE AND RELIABLE CONTROL FOR IE2, IE3, IE4 & IE5 MOTORS

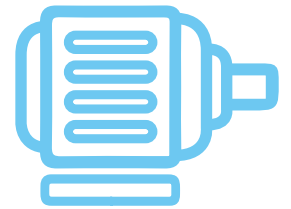

UP TO 5 YEAR WARRANTY

World class reliability leading to three years warranty as standard, extendable to five years.



Compliance with C2 conducted emissions for all ratings without the need for external filters. C1 compliance achievable with external filter option.



3 years warranty as standard extended warranty available



No need for external chokes



Separate Stop Ramp avoid unwanted pump-down



Widest power range and smallest footprint



A3 & A2L Refrigerant compatible

HEATSINK VERSION

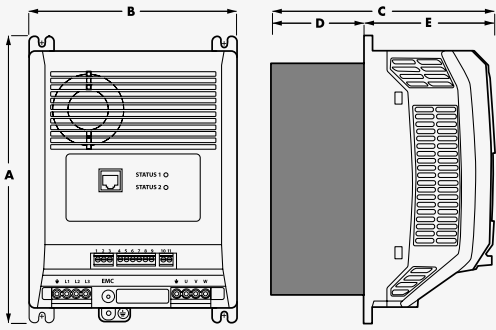

	A		B		C		D		E	
	mm	in	mm	in	mm	in	mm	in	mm	in
Size 2	226	8.9	165	6.5	177	7.0	72	2.8	104	4.1
Size 3	278	10.9	194	7.6	200	7.9	84	3.3	116	4.6
Size 4	364	14.3	240	9.4	231	9.1	98	3.9	133	5.2
Size 5	364	14.3	240	9.4	240	9.4	107	4.2	133	5.2

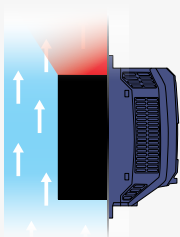

THROUGH PANEL MOUNTING

IP20 Front **IP55 Rear**

Through panel mounting allows the drive power electronics to be cooled by the chilled air.

Allowing OEM's to select the smallest electrical panel size, for the control electronics, while safely removing the heat generated by the drive, and maintaining IP rating.

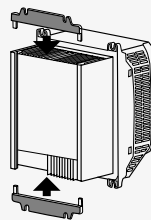

FRONT PANEL MOUNTING

The Coolvert can also be mounted on the face of the panel using the mounting kit shown to the left.

- Size 2 **OPT-3-CVBKT-S2**
- Size 3 **OPT-3-CVBKT-S3**
- Size 4/5 **OPT-3-CVBKT-S4/5**

COLDPLATE VERSION

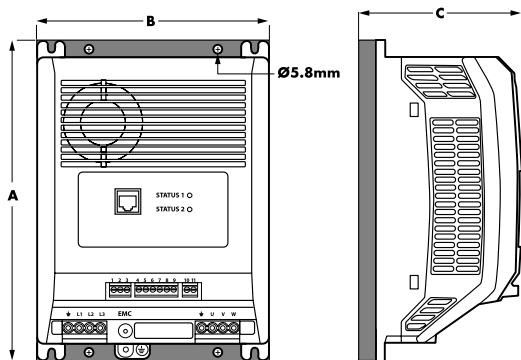

	A		B		C	
	mm	in	mm	in	mm	in
Size 2	226	8.9	165	6.5	114	4.5
Size 3	278	10.9	194	7.6	126	5.0
Size 4	364	14.3	240	9.4	140	5.5
Size 5	364	14.3	240	9.4	141	5.5

Specifications are identical to the standard Coolvert except the heatsink is replaced with a flat aluminium coldplate. This allows the Coolvert to be fixed to a device containing its own heat exchanger which then dissipates the heat from the drive.

OPTIONS FOR COMMISSIONING & DIAGNOSTICS

Optistick Smart

OPT-3-STICK-IN

Rapid Commissioning Tool



- Copying, backup and restore of drive parameters
- Bluetooth interface to a PC running OptiTools Studio or the OptiTools Mobile app on a smartphone
- Onboard NFC (Near Field Communication) for rapid data transfer



RJ45 Splitter

OPT-J45SP-IN

Ideal for simple and fast connection of Modbus RTU/ CAN networks



Optipad

OPT-3-OPPAD-IN

Remote Keypad with TFT Display





SPECIFICATIONS

	kW	HP	Amps	Size	Product Family	Frame Size	Voltage Code	Power Rating Code	Number of Inputs Phases	EMC Filter	Heatsink/Coldplate	Power Technology	
200 – 240V ± 10% 1 Phase Input	1.5	2	7.0	2	CV	-	2	0070	-	1	F	#	P
	3	4	12	2	CV	-	2	0120	-	1	F	#	P
	4	5.5	16.0	2	CV	-	2	0160	-	1	F	#	P
	5.5	7.5	20.0	2	CV	-	2	0200	-	1	F	#	P
380 – 480V ± 10% 3 Phase Input	5.5	7.5	14	2	CV	-	2	0140	-	3	F	#	E
	7.5	10	18	2	CV	-	2	0180	-	3	F	#	E
	11	15	24	2	CV	-	2	0240	-	3	F	#	E
	15	20	30	3	CV	-	3	0300	-	3	F	#	E
	18.5	25	39	3	CV	-	3	0390	-	3	F	#	E
	22	30	46	4	CV	-	4	0460	-	3	F	#	E
	30	40	58	4	CV	-	4	0580	-	3	F	#	E
	37	45	65	5	CV	-	5	0650	-	3	F	#	E
	40	50	75	5	CV	-	5	0750	-	3	F	#	E

Replace # in model code with colour-coded option

Heatsink/Coldplate

H  Heatsink Version

C  Coldplate Version

Input Ratings	Supply Voltage	200 – 240V ± 10% 380 – 480V ± 10%
	Supply Frequency	48 – 62Hz
	Displacement Power Factor	> 0.98
	Phase Imbalance	3% Maximum allowed
	Inrush Current	< rated current
Output Ratings	Output Power	200V: 7.0A to 20A 400V: 14A to 75A
	Overload Capacity	130% rated current for 10s
	Output Frequency	0 – 500Hz
	Acceleration Time	0.01 – 600 seconds
	Deceleration Time	0.01 – 600 seconds
	Typical Efficiency	> 98%
Ambient Conditions	Temperature	Storage: -40 to 70°C Operating: -20 to 60°C
	Altitude	Up to 1000m ASL without derating Up to 2000m maximum
	Humidity	95% Max, non condensing
	Vibration	Conforms to EN61800-5-1
Enclosure	Ingress Protection (IP)	Front IP20 Rear (Through Panel Mounting) IP55
	Coated PCBs	Designed for operation in 3S2/3C2 environments according to IEC 60721-3-3
Programming	Modbus RTU (RS485)	Modbus RTU on Pluggable terminals and through RJ45 port
	PC Tools	PC Tools software for Diagnostics and parameter configuration (RJ45 port only)
	Keypad	Optional Remote Keypad with TFT display for diagnostic and programming
	Smartphone app	Optitools Mobile
Control Specification	PWM Frequency	4 – 32kHz
	Control Modes	Modbus RTU (RS485) Terminal Control Digital / Analogue Terminal Control PI mode Master / Slave Mode

Safe Torque Off (STO)	IEC 61800-5-2:2016	SIL 3
	UL 61800-5-2:2022	SIL 3
	Independent Approval	TUV Rheinland / UL
Maintenance & Diagnostics	Fault Memory	Last 3 trips stored with time stamp
	Data Logging	Logging of data prior to trip for diagnostic purposes
	Monitoring	Hours Run Meter kWh
Conformance	The Coolvert product range conforms to the relevant safety provisions of the following council directives: 2014/30/EU (EMC), 2014/35/EU (LVD), 2006/42/EC (Machinery Directive), 2011/65/EU (RoHS 2) and 2009/125/EC (Eco-design)	
	Design and manufacture is in accordance with the following harmonised European standards:	
	BSEN 61800-5-1:2007 & A1:2017	Adjustable speed electrical power drive systems. Safety requirements. Electrical, thermal and energy.
	BSEN 61800-3:2018	Adjustable speed electrical power drive systems. Part 3: EMC requirements and specific test methods (IEC 61800-3:2017).
	BSEN 61800-9-2:2017	Adjustable speed electrical power drive systems. Part 9-2: Ecodesign for power drive systems, motor starters, power electronics and their driven applications – Energy efficiency indicators for power drive systems and motor starters (IEC 61800-9-2:2017).
	BSEN 60529:1992 & A2:2013	Specifications for degrees of protection provided by enclosures
	BSEN 61800-5-2:2017	Adjustable speed electrical power drive systems. [as relevant] Part 5-2: Safety requirements – Functional (IEC 61800-5-2:2016).
	UL 61800-5-1	cUL Listed cUR Recognised for the coldplate variants
	BSEN 61000-3-12:2011	Electromagnetic compatibility (EMC) - Part 3-12: Limits - Limits for harmonic currents produced by equipment connected to public low voltage systems with input current >16 A and ≤ 75 A per phase
	BSEN 61000-3-2:2019 (single phase input variants only)	Electromagnetic compatibility (EMC). Limits - Limits for harmonic current emissions (equipment input current ≤ 16 A per phase)

www.invertekdrives.com

INVERTEK DRIVES LIMITED UK Headquarters

Offa's Dyke Business Park
Welshpool, Powys, UK
SY21 8JF

Tel: +44 (0)1938 556868
Fax: +44 (0)1938 556869
Email: sales@invertekdrives.com

