

INVERTER

FR-A 700

INSTALLATION GUIDELINE

FR-A 740-00023 to 12120-EC

Thank you for choosing this Mitsubishi Inverter.

Please read through this Instruction Manual and the enclosed CD ROM to operate this inverter correctly

- The enclosed CD ROM contains the Installation Guideline in additional languages.
- Die CD-ROM enthält die deutsche Installationsbeschreibung.
- Il CD-ROM incluso contiene la guida di riferimento dell'installazione in lingua italiana.
- Le CD-ROM ci-joint contient cette documentation en français.
- El CD-ROM incluido contiene la pauta de la instalación en lengua española.
- Приложенный CD-ROM содержит инструкцию по инсталляции на дополнительных языках.

Do not use this product until you have a full knowledge of the equipment, the safety information and the instructions.

Please forward this manual and the CD ROM to the end user.

CONTENTS

1	INSTALLATION OF THE INVERTER AND INSTRUCTIONS	1
2	OUTLINE DRAWING	3
3	WIRING	4
4	PRECAUTIONS FOR USE OF THE INVERTER	10
5	TROUBLESHOOTING	11

*A*700

Print Date	Manual Number	Revision
12/2006 pdp-dk	192716	First edition

 **For Maximum Safety**

- Mitsubishi transistorized inverters are not designed or manufactured to be used in equipment or systems in situations that can affect or endanger human life.
- When considering this product for operation in special applications such as machinery or systems used in passenger transportation, medical, aerospace, atomic power, electric power, or submarine repeating applications, please contact your nearest Mitsubishi sales representative.
- Although this product was manufactured under conditions of strict quality control, you are strongly advised to install safety devices to prevent serious accidents when it is used in facilities where breakdowns of the product are likely to cause a serious accident.
- Please do not use this product for loads other than three-phase induction motors.
- Please check upon receiving of the inverter whether this instruction manual corresponds to the delivered inverter. Compare the specifications on the capacity plate with the specifications given in this manual.

This section is specifically about safety matters

Do not attempt to install, operate, maintain or inspect the inverter until you have read through this Installation Guideline and appended documents carefully and can use the equipment correctly. Do not use the inverter until you have a full knowledge of the equipment, safety information and instructions. In this Installation Guideline, the safety instruction levels are classified into "WARNING" and "CAUTION".



WARNING

Assumes that incorrect handling may cause hazardous conditions, resulting in death or severe injury.



CAUTION

Assumes that incorrect handling may cause hazardous conditions, resulting in medium or slight injury, or may cause physical damage only.

Note that even the **CAUTION** level may lead to a serious consequence according to conditions. Please follow strictly the instructions of both levels because they are important to personnel safety.

Electric Shock Prevention

WARNING

- While power is on or when the inverter is running, do not open the front cover. Otherwise you may get an electric shock.
- Do not run the inverter with the front cover removed. Otherwise, you may access the exposed high-voltage terminals or the charging part of the circuitry and get an electric shock.
- Even if power is off, do not remove the front cover except for wiring or periodic inspection. You may access the charged inverter circuits and get an electric shock.
- Before starting wiring or inspection, check to make sure that the operation panel indicator is off, wait for at least 10 minutes after the power supply has been switched off, and check that there are no residual voltage using a tester or the like. The capacitor is charged with high voltage for some time after power off and it is dangerous.
- This inverter must be earthed (grounded). Earthing (Grounding) must conform to the requirements of national and local safety regulations and electrical codes. (JIS, NEC section 250, IEC 536 class 1 and other applicable standards)
- Any person who is involved in the wiring or inspection of this equipment should be fully competent to do the work.
- Always install the inverter before wiring. Otherwise, you may get an electric shock or be injured.
- Perform setting dial and key operations with dry hands to prevent an electric shock. Otherwise you may get an electric shock.
- Do not subject the cables to scratches, excessive stress, heavy loads or pinching. Otherwise you may get an electric shock.
- Do not replace the cooling fan while power is on. It is dangerous to replace the cooling fan while power is on.
- Do not touch the printed circuit board with wet hands. You may get an electric shock.

Fire Prevention

CAUTION

- Mount the inverter to incombustible material. Mounting it to or near combustible material can cause a fire.
- If the inverter has become faulty, switch off the inverter power. A continuous flow of large current could cause a fire.
- When using a brake resistor, make up a sequence that will turn off power when an alarm signal is output. Otherwise, the brake resistor may excessively overheat due to damage of the brake transistor and such, causing a fire.
- Do not connect a resistor directly to the DC terminals P, N. This could cause a fire and destroy the inverter. The surface temperature of braking resistors can far exceed 100°C for brief periods. Make sure that there is adequate protection against accidental contact and a safe distance is maintained to other units and system parts.

Injury Prevention

CAUTION

- Apply only the voltage specified in the instruction manual to each terminal. Otherwise, burst, damage, etc. may occur.
- Ensure that the cables are connected to the correct terminals. Otherwise, burst, damage, etc. may occur.
- Always make sure that polarity is correct to prevent damage, etc. Otherwise, burst, damage, etc. may occur.
- While power is on or for some time after power-off, do not touch the inverter as it is hot and you may get burnt.

Additional Instructions

Also note the following points to prevent an accidental failure, injury, electric shock, etc.

Transportation and installation

CAUTION

- When carrying products, use correct lifting gear to prevent injury.
- Do not stack the inverter boxes higher than the number recommended.
- Ensure that installation position and material can withstand the weight of the inverter. Install according to the information in the instruction manual.
- Do not install or operate the inverter if it is damaged or has parts missing. This can result in breakdowns.
- When carrying the inverter, do not hold it by the front cover or setting dial; it may fall off or fail.
- Do not stand or rest heavy objects on the product.
- Check the inverter mounting orientation is correct.
- Prevent other conductive bodies such as screws and metal fragments or other flammable substance such as oil from entering the inverter.
- As the inverter is a precision instrument, do not drop or subject it to impact.
- Use the inverter under the following environmental conditions. Otherwise, the inverter may be damaged.

Operating condition	Ambient temperature	LD (150 %), ND (200 %, initial setting) and HD (250 %) SLD (120 %)	-10°C to +50°C (non-freezing)
	Ambient humidity		-10°C to +40 °C (non-freezing)
	Storage temperature		90% RH or less (non-condensing)
	Atmosphere		-20°C to +65°C ①
	Altitude		Indoors (free from corrosive gas, flammable gas, oil mist, dust and dirt)
	Vibration		Maximum 1000 m above sea level for standard operation. After that derate by 3% for every extra 500m up to 2500m (91%)
			5.9m/s ² ② or less (conforming to JIS C 60068-2-6)

① Temperature applicable for a short time, e.g. in transit.

② 2.9m/s² or less for the 04320 or more.

Wiring

⚠ CAUTION

- Do not install assemblies or components (e. g. power factor correction capacitors) on the inverter output side, which are not approved from Mitsubishi.
- The direction of rotation of the motor corresponds to the direction of rotation commands (STF/STR) only if the phase sequence (U, V, W) is maintained.

Test operation and adjustment

⚠ CAUTION

- Before starting operation, confirm and adjust the parameters. A failure to do so may cause some machines to make unexpected motions.

Operation

⚠ WARNING

- When you have chosen the retry function, stay away from the equipment as it will restart suddenly after an alarm stop.
- The  key is valid only when the appropriate function setting has been made. Prepare an emergency stop switch separately.
- Make sure that the start signal is off before resetting the inverter alarm. A failure to do so may restart the motor suddenly.
- The inverter can be started and stopped via the serial port communications link or the field bus. However, please note that depending on the settings of the communications parameters it may not be possible to stop the system via these connections if there is an error in the communications system or the data line. In configurations like this it is thus essential to install additional safety hardware that makes it possible to stop the system in an emergency (e.g. controller inhibit via control signal, external motor contactor etc). Clear and unambiguous warnings about this must be posted on site for the operating and service staff.
- The load used should be a three-phase induction motor only. Connection of any other electrical equipment to the inverter output may damage the inverter as well as the equipment.
- Performing pre-excitation (LX signal and X13 signal) under torque control (real sensorless vector control) may start the motor running at a low speed even when the start command (STF or STR) is not input. The motor may run also at a low speed when the speed limit value = 0 with a start command input. Perform pre-excitation after making sure that there will be no problem in safety if the motor runs.
- Do not modify the equipment.
- Do not perform parts removal which is not instructed in this manual. Doing so may lead to fault or damage of the inverter.

⚠ CAUTION

- The electronic thermal relay function does not guarantee protection of the motor from overheating.
- Do not use a magnetic contactor on the inverter input for frequent starting/stopping of the inverter.
- Use a noise filter to reduce the effect of electromagnetic interference and follow the accepted EMC procedures for proper installation of frequency inverters. Otherwise nearby electronic equipment may be affected.
- Take appropriate measures regarding harmonics. Otherwise this can endanger compensation systems or overload generators.
- Use a motor designed for inverter operation. (The stress for motor windings is bigger than in line power supply).
- When parameter clear or all clear is performed, set again the required parameters before starting operations. Each parameter returns to the initial value.
- The inverter can be easily set for high-speed operation. Before changing its setting, fully examine the performances of the motor and machine.
- The DC braking function of the frequency inverter is not designed to continuously hold a load. Use an electro-mechanical holding brake on the motor for this purpose.
- Before running an inverter which had been stored for a long period, always perform inspection and test operation.
- For prevention of damage due to static electricity, touch nearby metal before touching this product to eliminate static electricity from your body.

Emergency stop

⚠ CAUTION

- Provide a safety backup such as an emergency brake which will prevent the machine and equipment from hazardous conditions if the inverter fails.
- When the breaker on the inverter primary side trips, check for the wiring fault (short circuit), damage to internal parts of the inverter, etc. Identify the cause of the trip, then remove the cause and power on the breaker.
- When the protective function is activated (i. e. the frequency inverter switches off with an error message), take the corresponding corrective action as described in the inverter manual, then reset the inverter, and resume operation.

Maintenance, inspection and parts replacement

⚠ CAUTION

- Do not carry out a megger (insulation resistance) test on the control circuit of the inverter.

Disposing of the inverter

⚠ CAUTION

- Treat as industrial waste.

General instructions

Many of the diagrams and drawings in instruction manuals show the inverter without a cover, or partially open. Never run the inverter in this status. Always replace the cover and follow instruction manuals when operating the inverter.

1 INSTALLATION

1.1 Inverter Type

FR - **A740** - **00126** - EC

Symbol	Voltage Class	Symbol	Type number
A740	Three-phase 400V class	00023 to 12120	Displays the rated current

Capacity plate example

Capacity plate	FR-A740-00126-EC xxxxxx
	↑ Inverter type ↑ Serial number

Rating plate example

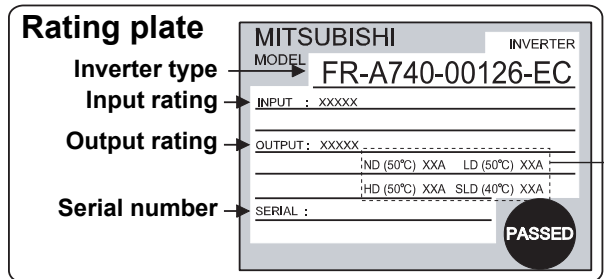

	Overload current rating	Ambient temperature
SLD	110% 60s, 120% 3s	40°C
LD	120% 60s, 150% 3s	50°C
ND	150% 60s, 200% 3s	50°C
HD	200% 60s, 250% 3s	50°C

1.2 Installation of the inverter

Installation on the panel

00023 to 00620

00770 to 12120

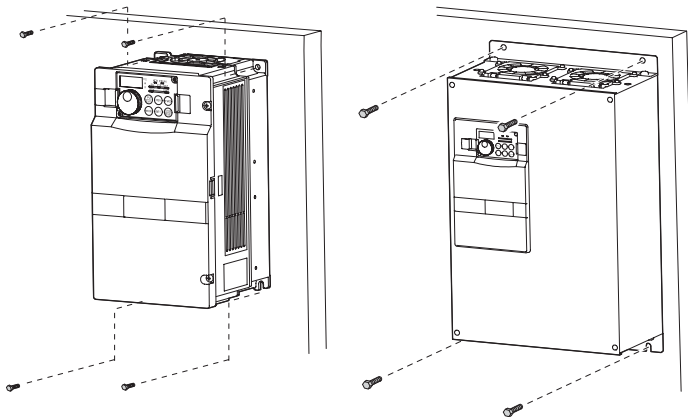

Fix six positions for the FR-A 740-04320 to 08660 and fix eight positions for the R-A 740-09620 to 12120.

CAUTION

- When encasing multiple inverters, install them in parallel and leave clearance as a cooling measure.
- Install the inverter vertically.

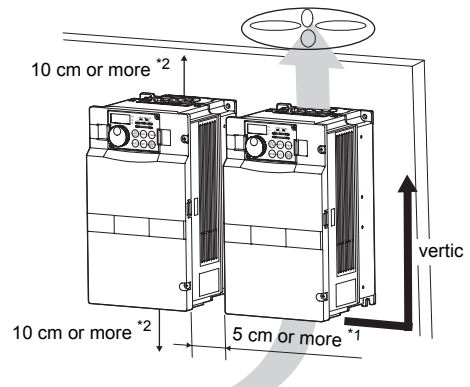

*1 1 cm or more for 00126 or less
10 cm or more for 02160 or more
*2 20 cm or more for 02160 or more

Note

- The internal filter is suitable for the second environment, a motor cable length of up to 5m and a carrier frequency of up to 2kHz. For other operation conditions, Mitsubishi Electric offers several optional filters. Please contact your sales representative.



1.3 General Precaution

The bus capacitor discharge time is 10 minutes. Before starting wiring or inspection, switch power off, wait for more than 10 minutes, and check for residual voltage between terminal P/+ and N/- with a meter etc., to avoid a hazard of electrical shock.

1.4 Environment

Before installation, check that the environment meets following specifications.

Ambient temperature	-10°C to +50°C (non-freezing) for selected overload capability 150 %, 200 % (initial setting) or 250 % -10°C to +40°C (non-freezing) for selected overload capability 120 %	
Ambient humidity	90% RH or less (non-condensing)	
Storage temperature	-20°C to +65°C	
Ambience	Indoors (No corrosive and flammable gases, oil mist, dust and dirt)	
Altitude, vibration	Below 1000m, 5.9m/s ² ① or less	

① 2.9m/s² or less for the 04320 or more.

CAUTION

- Install the inverter on a strong surface securely and vertically with bolts.
- Leave enough clearances and take cooling measures.
- Avoid places where the inverter is subjected to direct sunlight, high temperature and high humidity.
- Install the inverter on a non-combustible surface.

2 OUTLINE DRAWING

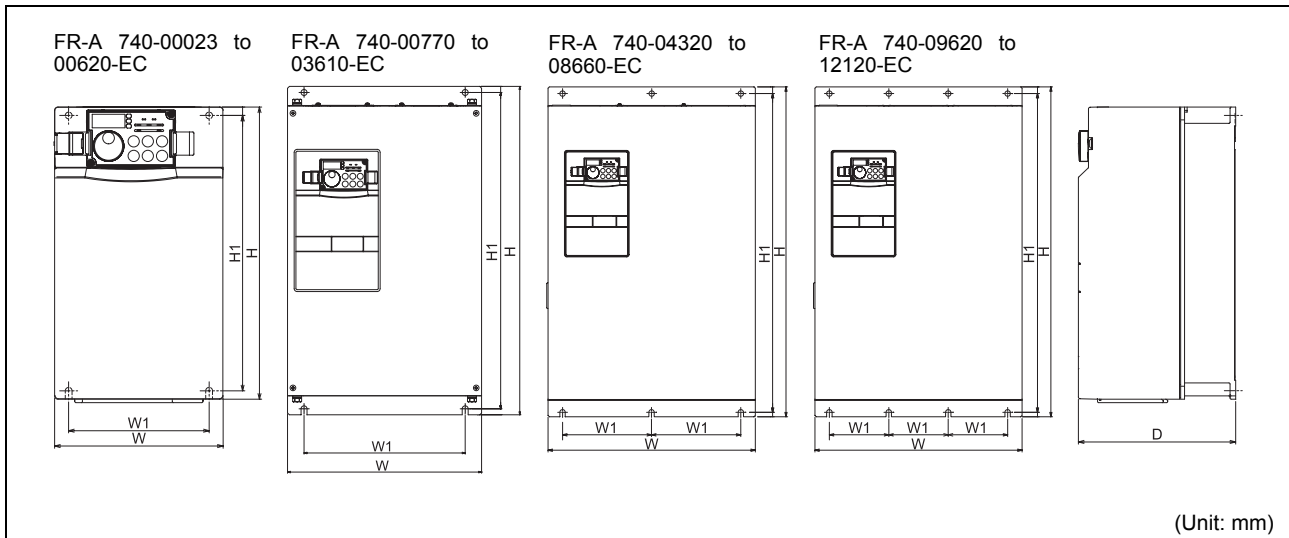

Inverter Type	W	W1	H	H1	D
FR-A 740-00023-EC	150	125	260	245	140
FR-A 740-00038-EC					
FR-A 740-00052-EC					
FR-A 740-00083-EC					
FR-A 740-00126-EC					
FR-A 740-00170-EC	220	195	300	285	170
FR-A 740-00250-EC					
FR-A 740-00310-EC					
FR-A 740-00380-EC					
FR-A 740-00470-EC	250	230	400	380	190
FR-A 740-00620-EC					
FR-A 740-00770-EC					
FR-A 740-00930-EC	435	380	550	525	250
FR-A 740-01160-EC					
FR-A 740-01800-EC					
FR-A 740-02160-EC	465	400	620	595	300
FR-A 740-02600-EC					
FR-A 740-03250-EC			740		
FR-A 740-03610-EC			985		
FR-A 740-04320-EC					
FR-A 740-04810-EC	680	300	1010	984	380
FR-A 740-05470-EC					
FR-A 740-06100-EC					
FR-A 740-06830-EC					
FR-A 740-07700-EC	790	315	1330	1300	440
FR-A 740-08660-EC					
FR-A 740-09620-EC					
FR-A 740-10940-EC	995	300	1580	1550	440
FR-A 740-12120-EC					

3 WIRING

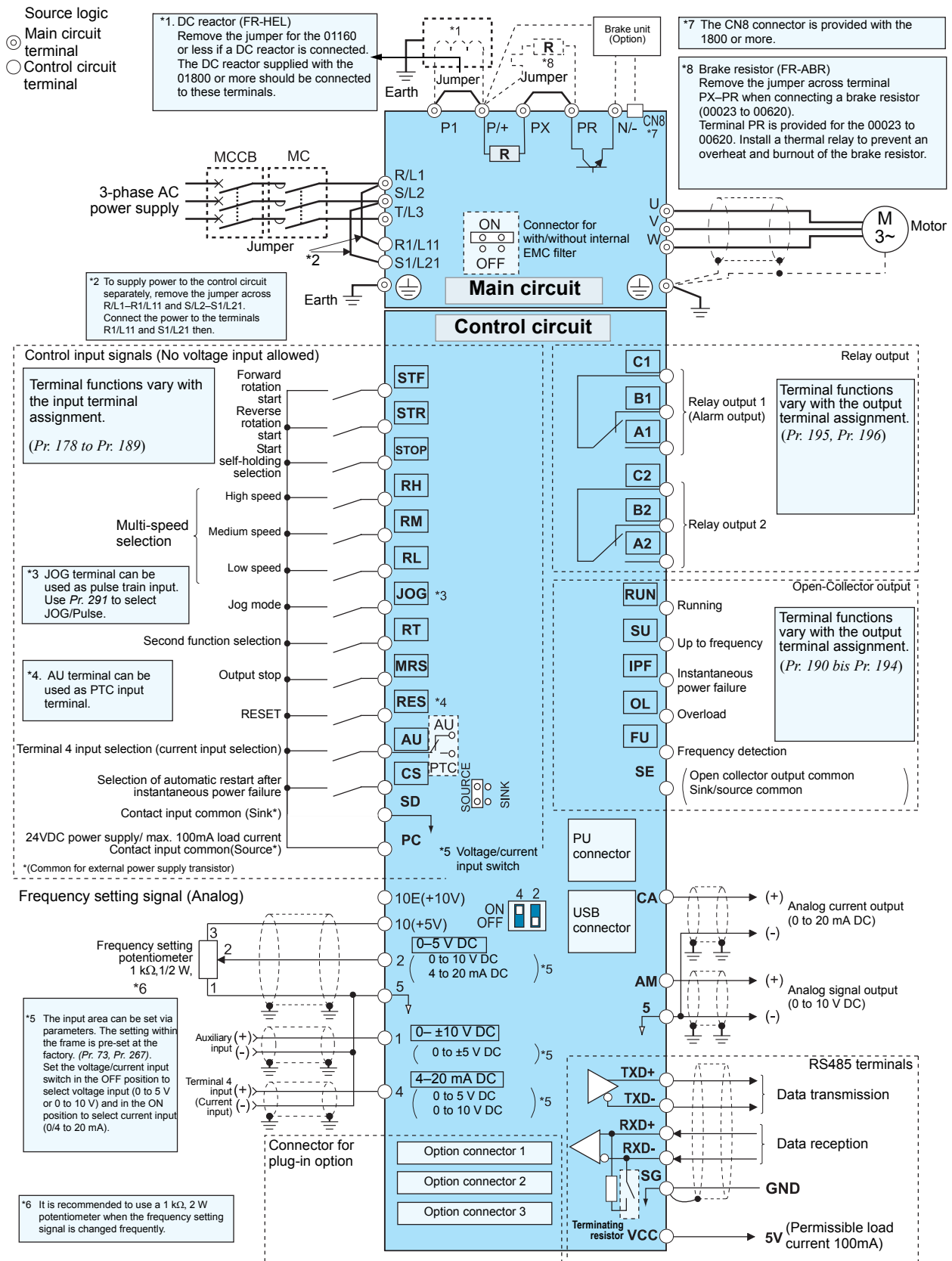

CAUTION

- To prevent a malfunction due to noise, keep the signal cables more than 10cm away from the power cables.
- After wiring, wire offcuts must not be left in the inverter. Wire offcuts can cause an alarm, failure or malfunction. Always keep the inverter clean. When drilling mounting holes in a control box etc., take care not to allow chips and other foreign matter to enter the inverter.
- Set the voltage/current input switch in the correct position. An incorrect setting may cause a fault, failure or malfunction.

3.1 Main circuit terminal

3.1.1 Terminal layout and wiring

FR-A 740-00023, 00038, 00052, 00083, 00126-EC

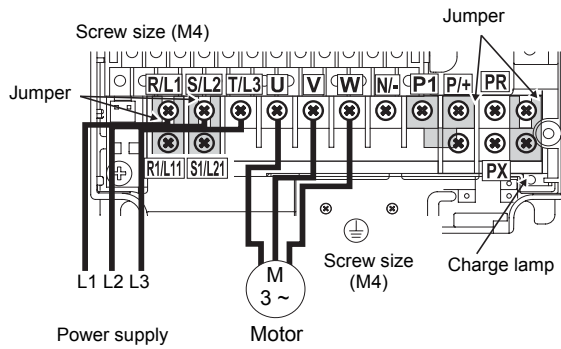

FR-A 740-00170, 00250-EC

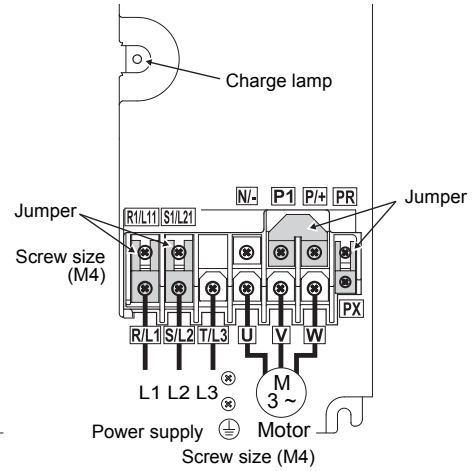

FR-A 740-00310, 00380-EC

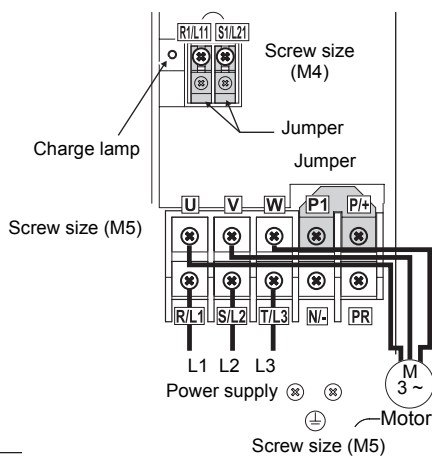

FR-A 740-00470, 00620-EC

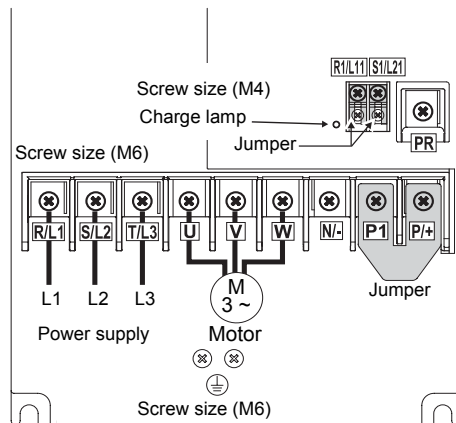

FR-A 740-00770, 00930, 01160-EC

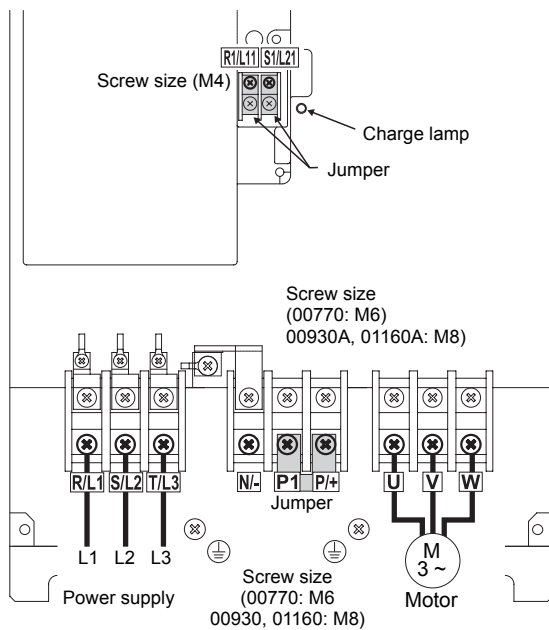

FR-A 740-01800-EC

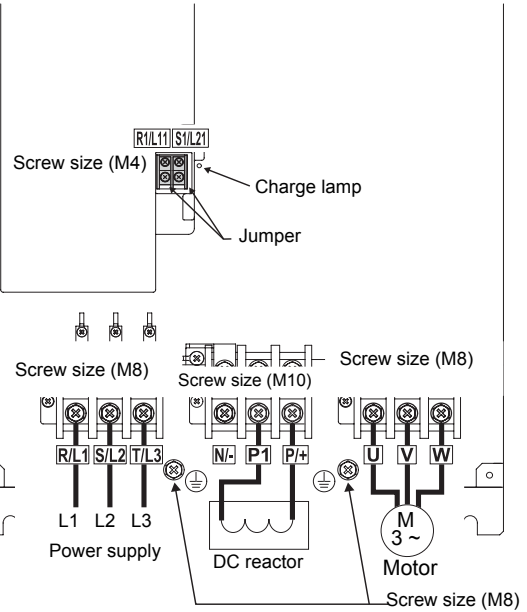



FR-A 740-02160, 02600-EC

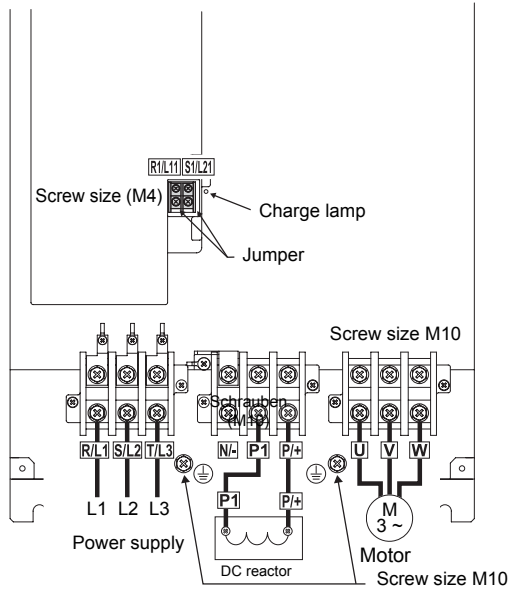

FR-A 740-03250, 03610-EC

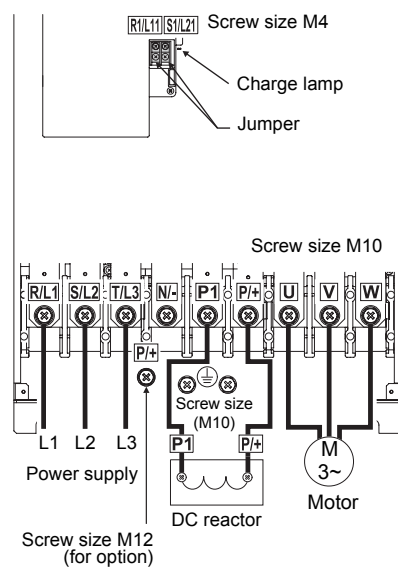

FR-A 740-04320, 04810-EC

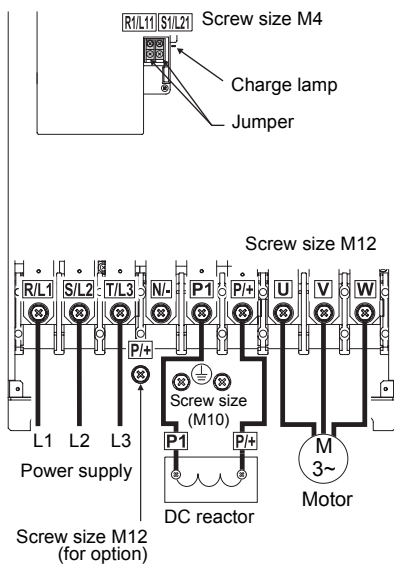

FR-A 740-05470 bis 12120-EC

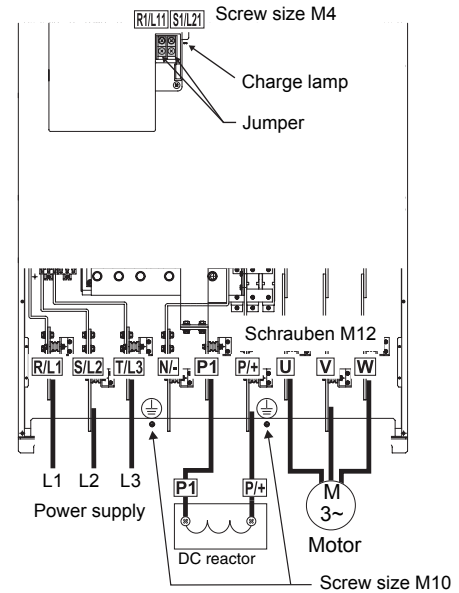

CAUTION

- The power supply cables must be connected to R/L1, S/L2, T/L3. Never connect the power cable to the U, V, W, of the inverter. Doing so will damaged the inverter. (Phase sequence needs not to be matched.)
- Connect the motor to U, V, W. At this time turning on the forward rotation switch (signal) rotates the motor in the clockwise direction when viewed on the motor shaft.
- When wiring the inverter main circuit conductor of the FR-A740-0432005470 or more, tighten a nut from the right side of the conductor. When wiring two wires, place wires on both sides of the conductor. (Refer to the drawing below.) For wiring, use bolts (nuts) provided with the inverter.

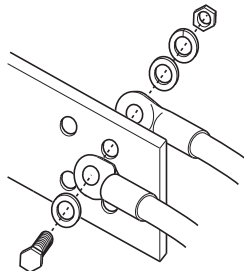

3.2 Wiring fundamentals

3.2.1 Cable size

Select the recommended cable size to ensure that a voltage drop will be 2% max.

If the wiring distance is long between the inverter and motor, a main circuit cable voltage drop will cause the motor torque to decrease especially at the output of a low frequency.

The following table indicates a selection example for the wiring length of 20m.

400V class (when input power supply is 440V)

Applicable Inverter Type	Terminal Screw Size *4	Tightening Torque [Nm]	Crimping Terminal	
			R/L1, S/L2, T/L3	U, V, W
FR-A 740-00023-00126-EC	M4	1.5	2-4	2-4
FR-A 740-00170-EC	M4	1.5	2-4	2-4
FR-A 740-00250-EC	M4	1.5	5.5-4	5.5-4
FR-A 740-00310-EC	M5	2.5	5.5-5	5.5-5
FR-A 740-00380-EC	M5	2.5	8-5	8-5
FR-A 740-00470-EC	M6	4.4	14-6	8-6
FR-A 740-00620-EC	M6	4.4	14-6	14-6
FR-A 740-00770-EC	M6	4.4	22-6	22-6
FR-A 740-00930-EC	M8	7.8	22-8	22-8
FR-A 740-01160-EC	M8	7.8	38-8	38-8
FR-A 740-01800-EC	M8	7.8	60-8	60-8
FR-A 740-02160-EC	M10	14.7	60-10	60-10
FR-A 740-02600-EC	M10	14.7	60-10	60-10
FR-A 740-03250-EC	M10/M12	14.7	80-10	80-10
FR-A 740-03610-EC	M10/M12	14.7	100-10	100-10
FR-A 740-04320-EC	M12/M10	24.5	150-12	150-12
FR-A 740-04810-EC	M12/M10	24.5	150-12	150-12
FR-A 740-05470-EC	M12/M10	24.5	100-12	100-12
FR-A 740-06100-EC	M12/M10	24.5	100-12	100-12
FR-A 740-06830-EC	M12/M10	24.5	150-12	150-12
FR-A 740-07700-EC	M12/M10	24.5	150-12	150-12
FR-A 740-08660-EC	M12/M10	24.5	C2-200	C2-200
FR-A 740-09620-EC	M12/M10	24.5	C2-200	C2-200
FR-A 740-10940-EC	M12/M10	24.5	C2-250	C2-250
FR-A 740-12120-EC	M12/M10	24.5	C2-200	C2-250



Applicable Inverter Type	Cable Sizes								
	HIV, etc. [mm ²] *1				AWG *2		PVC, etc. [mm ²] *3		
	R/L1, S/L2, T/L3	U, V, W	P/+, P1	Earth Cable Gauge	R/L1, S/L2, T/L3	U, V, W	R/L1, S/L2, T/L3	U, V, W	Earth Cable Gauge
FR-A 740-00023-00126-EC	2	2	2	2	14	14	2.5	2.5	2.5
FR-A 740-00170-EC	2	2	3.5	3.5	12	14	2.5	2.5	4
FR-A 740-00250-EC	3.5	3.5	3.5	3.5	12	12	4	4	4
FR-A 740-00310-EC	5.5	5.5	5.5	8	10	10	6	6	10
FR-A 740-00380-EC	8	8	8	8	8	8	10	10	10
FR-A 740-00470-EC	14	8	14	14	6	8	16	10	16
FR-A 740-00620-EC	14	14	22	14	6	6	16	16	16
FR-A 740-00770-EC	22	22	22	14	4	4	25	25	16
FR-A 740-00930-EC	22	22	22	14	4	4	25	25	16
FR-A 740-01160-EC	38	38	38	22	1	2	50	50	25
FR-A 740-01800-EC	60	60	60	22	1/0	1/0	50	50	25
FR-A 740-02160-EC	60	60	60	38	1/0	1/0	50	50	25
FR-A 740-02600-EC	60	60	80	38	3/0	3/0	50	50	25
FR-A 740-03250-EC	80	80	80	38	3/0	3/0	70	70	35
FR-A 740-03610-EC	100	100	100	38	4/0	4/0	95	95	50
FR-A 740-04320-EC	125	150	150	38	250	250	120	120	70
FR-A 740-04810-EC	150	150	150	38	300	300	150	150	95
FR-A 740-05470-EC	2 x 100	2 x 100	2 x 100	60	2 x 4/0	2 x 4/0	2 x 95	2 x 95	95
FR-A 740-06100-EC	2 x 100	2 x 100	2 x 125	60	2 x 4/0	2 x 4/0	2 x 95	2 x 95	95
FR-A 740-06830-EC	2 x 125	2 x 125	2 x 125	60	2 x 250	2 x 250	2 x 120	2 x 120	120
FR-A 740-07700-EC	2 x 150	2 x 150	2 x 150	100	2 x 300	2 x 300	2 x 150	2 x 150	150
FR-A 740-08660-EC	2 x 200	2 x 200	2 x 200	100	2 x 350	2 x 350	2 x 185	2 x 185	2 x 95
FR-A 740-09620-EC	2 x 200	2 x 200	2 x 200	100	2 x 400	2 x 400	2 x 185	2 x 185	2 x 95
FR-A 740-10940-EC	2 x 250	2 x 250	2 x 250	100	2 x 500	2 x 500	2 x 240	2 x 240	2 x 120
FR-A 740-12120-EC	3 x 200	2 x 250	3 x 200	2 x 100	2 x 500	2 x 500	2 x 240	2 x 240	2 x 120

*1 For the 01800 or less, the recommended cable size is that of the HIV cable (600V class 2 vinyl-insulated cable) with continuous maximum permissible temperature of 75°C. Assumes that the ambient temperature is 50°C or less and the wiring distance is 20m or less.

For the 02160 or more, the recommended cable size is that of LMFC (heat resistant flexible cross-linked polyethylene insulated cable) with continuous maximum permissible temperature of 90°C. Assumes that the ambient temperature is 50°C or less and wiring is performed in an enclosure.

*2 For the 01160 or less, the recommended cable size is that of the THHW cable with continuous maximum permissible temperature of 75°C. Assumes that the ambient temperature is 40°C or less and the wiring distance is 20m or less.

For the 01800 or more, the recommended cable size is that of THHN cable with continuous maximum permissible temperature of 90°C. Assumes that the ambient temperature is 40°C or less and wiring is performed in an enclosure. (Selection example for use mainly in the United States.)

*3 For the 01160 or less, the recommended cable size is that of the PVC cable with continuous maximum permissible temperature of 70°C. Assumes that the ambient temperature is 40°C or less and the wiring distance is 20m or less.

For the 01800 or more, the recommended cable size is that of XLPE cable with continuous maximum permissible temperature of 90°C. Assumes that the ambient temperature is 40°C or less and wiring is performed in an enclosure. (Selection example for use mainly in Europe.)

*4 The terminal screw size indicates the terminal size for R/L1, S/L2, T/L3, U, V, W, and a screw for earthing.

For the types 03250 and 03610, screw sizes are different (R/L1, S/L2, T/L3, U, V, W, screw for earthing: M10 / P/+ : M12).
For the types 04320 or more, screw sizes are different (R/L1, S/L2, T/L3, U, V, W / screw for earthing).

The line voltage drop can be calculated by the following expression:

$$\text{Line voltage drop [V]} = \frac{\sqrt{3} \times \text{wire resistance [m}\Omega\text{/m]} \times \text{wiring distance [m]} \times \text{current [A]}}{1000}$$

Use a larger diameter cable when the wiring distance is long or when it is desired to decrease the voltage drop (torque reduction) in the low speed range.

CAUTION

- Tighten the terminal screw to the specified torque.
A screw that has been tightened too loosely can cause a short circuit or malfunction.
A screw that has been tightened too tightly can cause a short circuit or malfunction due to the unit breakage.
- Use crimping terminals with insulation sleeve to wire the power supply and motor.

3.2.2 Maximum permissible motor wiring length

The maximum permissible length of the motor cables depends on the capacity of the inverter and the selected carrier frequency. (The wiring length should be 100 m maximum with vector control).

The lengths in the following table are for unshielded cables. When shielded cables are used divide the values listed in the table by 2. Note that the values are for the total wiring length – if you connect more than one motor in parallel you must add the lengths of the individual motor cables.

Setting of Pr. 72 PWM Frequency selection (carrier frequency)	00023	00038	≥ 00052
2 (2 kHz) or less	300 m	500 m	500 m
3 (3 kHz), 4 (4 kHz)	200 m	300 m	500 m
5 (5 kHz) to 9 (9 kHz)	100 m		
10 (10 kHz) or more	50 m		

Note

- For the 01800 or more, the setting range of Pr. 72 PWM frequency selection is "0 to 6".

Note that the motor windings in three-phase AC motors are subject to far more stress when operated via frequency inverters than with mains operation. The motor must have been approved by the manufacturer for operation on a frequency inverter.

CAUTION

- Especially for long-distance wiring (particularly when employing shielded motor cables), the inverter may be affected by a charging current caused by the stray capacitances of the wiring, leading to a malfunction of the overcurrent protective function or fast response current limit function or a malfunction or fault of the equipment connected on the inverter output side. When the fast-response current limit function malfunctions, make the function invalid. (For Pr.156 Stall prevention operation selection, refer to the Instruction Manual (applied).)
- For details of Pr. 72 PWM frequency selection, refer to the Instruction Manual (applied). (When using an option sine wave filter (MT-BSL/BSC) for the 02160 or more, set parameter 72 to „25“ (2.5 kHz).

3.2.3 Cable size of the control circuit power supply (terminals R1/L11, S1/L21)

- Terminal screw size: M4
- Cable size: 0.75mm² to 2 mm²
- Tightening torque: 1.5Nm

3.3 Control circuit terminals

3.3.1 Terminal layout

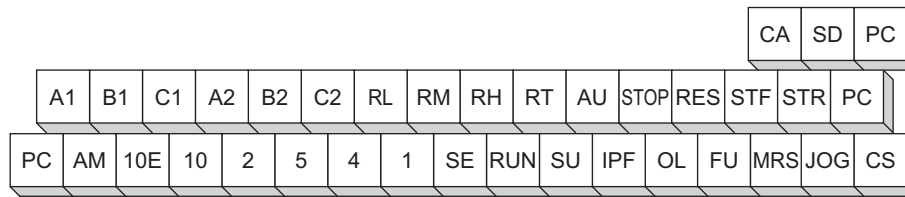

3.3.2 Instructions for wiring of the control circuit terminal

- Terminals PC, 5, and SE are all common terminals (0V) for I/O signals and are isolated from each other. Avoid connecting the terminal PC and 5 and the terminal SE and 5 (ground). Terminal PC is a common terminal for the contact input terminals (STF, STR, STOP, RH, RM, RL, JOG, RT, MRS, RES, AU, CS).
- Use shielded or twisted cables for connection to the control circuit terminals and run them away from the main and power circuits (including the 230V relay sequence circuit)..
- Use two or more parallel micro-signal contacts or twin contacts to prevent a contact faults when using contact inputs since the control circuit input signals are micro-currents.

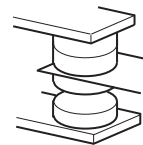

Micro signal contacts

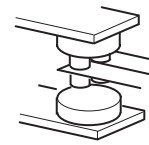

Zwillingskontakte

- Do not apply a voltage to the contact input terminals (e.g. STF) of the control circuit.
- Always apply a voltage to the alarm output terminals (A, B, C) via a relay coil, lamp, etc.
- It is recommended to use the cables of 0.75mm² gauge for connection to the control circuit terminals. If the cable gauge used is 1.25mm² or more, the front cover may be lifted when there are many cables running or the cables are run improperly, resulting in an operation panel contact fault.
- The wiring length should be 30m maximum.
- The level of the control signals can be switched over between positive (SOURCE) and negative (SINK) logic. The input signals are set to source logic when shipped from the factory. To change the control logic, the jumper connector on the control circuit terminal block must be removed to the other position.

4 PRECAUTIONS FOR USE OF THE INVERTER

The FR-A700 series is a highly reliable product, but incorrect peripheral circuit making or operation/handling method may shorten the product life or damage the product.

Before starting operation, always recheck the following items.

- Use crimping terminals with insulation sleeve to wire the power supply and motor.
- Application of power to the output terminals (U, V, W) of the inverter will damage the inverter. Never perform such wiring.
- After wiring, wire offcuts must not be left in the inverter.
Wire offcuts can cause an alarm, failure or malfunction. Always keep the inverter clean. When drilling mounting holes in a control box etc., take care not to allow chips and other foreign matter to enter the inverter.
- Use cables of the size to make a voltage drop 2% maximum.
If the wiring distance is long between the inverter and motor, a main circuit cable voltage drop will cause the motor torque to decrease especially at the output of a low frequency.
Refer to *page 7* for the recommended cable size.
- The overall wiring length should be 500m maximum.
(For vector control the wiring length should be 100m maximum.)
Especially for long distance wiring, the fast-response current limit function may be reduced or the equipment connected to the inverter output side may malfunction or become faulty under the influence of a charging current due to the stray capacity of the wiring. Therefore, note the overall wiring length. (Refer to *page 7*)
- Electromagnetic Compatibility
Operation of the frequency inverter can cause electromagnetic interference in the input and output that can be propagated by cable (via the power input lines), by wireless radiation to nearby equipment (e.g. AM radios) or via data and signal lines. Activate the integrated EMC filter (and an additional optional filter if present) to reduce air propagated interference on the input side of the inverter. Use AC or DC reactors to reduce line propagated noise (harmonics). Use shielded motor power lines to reduce output noise.
- Do not install a power factor correction capacitor, varistor or arrester on the inverter output side. This will cause the inverter to trip or the capacitor, varistor, or arrester to be damaged. If any of the above devices is installed, immediately remove it.
- Before starting wiring or other work after the inverter is operated, wait for at least 10 minutes after the power supply has been switched off, and check that there are no residual voltage using a tester or the like. The capacitor is charged with high voltage for some time after power off and it is dangerous.
- A short circuit or earth fault on the inverter output side may damage the inverter modules.
 - Fully check the insulation resistance of the circuit prior to inverter operation since repeated short circuits caused by peripheral circuit inadequacy or an earth fault caused by wiring inadequacy or reduced motor insulation resistance may damage the inverter modules.
 - Fully check the to-earth insulation and inter-phase insulation of the inverter output side before power-on.
Especially for an old motor or use in hostile atmosphere, securely check the motor insulation resistance etc.
- Do not use the inverter input side magnetic contactor to start/stop the inverter.
Always use the start signal (ON/OFF of STF and STR signals) to start/stop the inverter.
- Across P/+ and PR terminals, connect only an external regenerative brake discharge resistor. Do not connect a mechanical brake.
- Do not apply a voltage higher than the permissible voltage to the inverter I/O signal circuits.
Contact to the inverter I/O signal circuits or opposite polarity may damage the I/O devices. Especially check the wiring to prevent the speed setting potentiometer from being connected incorrectly to short terminals 10E (10, respectively) -5.
- Provide electrical and mechanical interlocks for MC1 and MC2 which are used for commercial power supply-inverter switch-over.
When the wiring is incorrect or if there is a commercial power supply-inverter switch-over circuit as shown below, the inverter will be damaged by leakage current from the power supply due to arcs generated at the time of switch-over or chattering caused by a sequence error. (Commercial operation can not be performed with the vector dedicated motor (SF-V5RU, SF-THY).)
- If the machine must not be restarted when power is restored after a power failure, provide a magnetic contactor in the inverter's input side and also make up a sequence which will not switch on the start signal.
If the start signal (start switch) remains on after a power failure, the inverter will automatically restart as soon as the power is restored.
- Instructions for overload operation
When performing operation of frequent start/stop of the inverter, increase/decrease in the temperature of the transistor element of the inverter may repeat due to a continuous flow of large current, shortening the life from thermal fatigue. Since thermal fatigue is related to the amount of current, the life can be increased by reducing bound current, starting current, etc. Decreasing current may increase the life. However, decreasing current will result in insufficient torque and the inverter may not start. Therefore, increase the inverter capacity to have enough allowance for current.
- Make sure that the specifications and rating match the system requirements.
- For vector control a motor with encoder is necessary. Connect the encoder directly to the backlash-free motor shaft. For real sensorless vector control an encoder is not necessary.

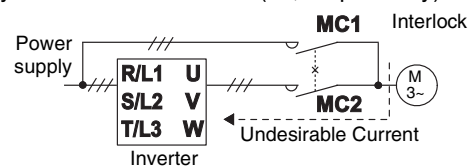



5 TROUBLESHOOTING

When an alarm occurs in the inverter, the protective function is activated bringing the inverter to an alarm stop and the PU display automatically changes to any of the following error (alarm) indications.

If your fault does not correspond to any of the following errors or if you have any other problem, please contact your sales representative.

- Retention of alarm output signal..... When the magnetic contactor (MC) provided on the input side of the inverter is opened at the activation of the protective function, the inverter's control power will be lost and the alarm output will not be held.
- Alarm display When the protective function is activated, the operation panel display automatically switches to the above indication.
- Resetting method When a protective function of the inverter is activated, the power output of the inverter is blocked (motor is coasting). The inverter cannot start up again unless an automatic restart has been configured or the inverter is reset. Please observe carefully the warnings contained below in the configuration of an automatic restart or the execution of a reset.
- If protective functions were activated (i. e. the inverter switched off with an error message) follow the instructions for error correction provided in the manual for the inverter. Especially in the case of short circuits or earth contacts in the inverter output and mains overvoltages the cause of the fault must be determined prior to switching on again as a recurrence of such faults at short intervals can lead to premature aging of components or even the complete breakdown of the device. After the cause of the fault has been found and corrected the inverter can be reset and operations continue.

Inverter alarm displays are roughly divided as below.

- Error Message
A message regarding operational fault and setting fault by the operation panel (FR-DU07) and parameter unit (FR-PU04 /FR-PU07) is displayed. The inverter does not shut off output.
- Warnings
The inverter does not shut off output even when a warning is displayed. However, failure to take appropriate measures will lead to a major fault.
- Minor fault
The inverter does not shut off output. You can also output a minor fault signal by making parameter setting.
- Major fault
When the protective function is activated, the inverter output is shut off and an alarm is output.

5.1 Reset method of protective function

Resetting the inverter

The inverter can be reset by performing any of the following operations. Note that the internal thermal integrated value of the electronic thermal relay function and the number of retries are cleared (erased) by resetting the inverter. Recover about 1s after reset is cancelled.

Three different methods can be used to reset an inverter.

- Using the operation panel, press the STOP/RESET key to reset the inverter.
(Enabled only when the inverter protective function is activated (major fault)).

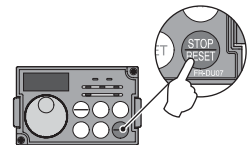

- Switch power off once, then switch it on again.

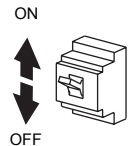

- Turn on the reset signal (RES) for more than 0.1s. (If the RES signal is kept on, "Err." appears (flickers) to indicate that the inverter is in a reset status.)

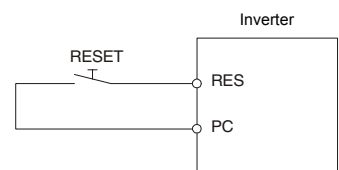

5.2 List of alarm display

Operation Panel Indication		Meaning	
Error messages	E ---	E ---	Alarm history
	HOLD	HOLD	Operation panel lock
	Er 1 bis Er 4	Er1 bis 4	Parameter write error
	rEr 1 bis rEr 4	rEr1 bis 4	Copy operation error
	Err.	Err.	Error
Warnings	OL	OL	Stall Prevention (overcurrent)
	oL	oL	Stall prevention (overvoltage)
	rb	RB	Regenerative brake prealarm
	TH	TH	Electronic thermal relay function prealarm
	PS	PS	PU Stop
	MT	MT	Maintenance signal output
	CP	CP	Parameter copy
	SL	SL	Speed limit indication (Output during speed limit)
Minor fault	F _n	FN	Fan fault
Major fault	E.OC 1	E.OC1	Overcurrent shut-off during acceleration
	E.OC 2	E.OC2	Overcurrent cut-off during constant speed
	E.OC 3	E.OC3	Overcurrent shutoff during deceleration or stop
	E.OV 1	E.OV1	Regenerative overvoltage shut-off during acceleration
	E.OV 2	E.OV2	Regenerative overvoltage shut-off during constant speed
	E.OV 3	E.OV3	Regenerative overvoltage shut-off during deceleration or stop
	E.THT	E.THT	Inverter overload shutoff (electronic thermal relay function)
	E.THM	E.THM	Motor overload shutoff (electronic thermal relay function)
	E.FIN	E.FIN	Fin overheat
	E.IPF	E.IPF	Instantaneous power failure protection
	E.UVT	E.UVT	Brake transistor alarm detection/Internal circuit error
	E.ILF	E.ILF*	Input phase failure
	E.OLT	E.OLT	Stall Prevention

Operation Panel Indication		Meaning	
E. GF	E.GF	Output side earth (ground) fault overcurrent protection	
E. LF	E.LF	Output phase failure protection	
E.OHT	E.OHT	External thermal relay operation	
E.PTC	E.PTC*	PTC-Thermistor-Auslösung	
E.OPT	E.OPT	Option alarm	
E.OP3	E.OP3	Communication option alarm	
E. 1 to E. 3	E. 1 bis E. 3	Option alarm (e. g. connection or contact fault)	
E. PE	E.PE	Parameter storage device alarm	
E.PUE	E.PUE	PU disconnection	
E.RET	E.RET	Retry count excess	
E.PE2	E.PE2*	Parameter storage device alarm	
E. 6, E. 7, E.CPU	E. 6 / E. 7 / E.CPU	CPU error	
E.CTE	E.CTE	Operation panel power supply short circuit RS-485 terminal power supply short circuit	
E.P24	E.P24	24VDC power output short circuit	
E.CDO	E.CDO*	Output current detection value exceeded	
E.IOH	E.IOH*	Inrush resistor overheat	
E.SER	E.SER*	Communication error (inverter)	
E.AIE	E.AIE*	Analog input error	
E. OS	E.OS	Overspeed occurrence	
E.OSd	E.OSD	Speed deviation excess detection	
E.ECT	E.ECT	Open cable detection	
E. Od	E.OD	Excessive position error	
E.MB 1 bis E.MB 7	E.MB1 bis E.MB7	Brake sequence error	
E.EP	E.EP	Encoder phase error	
E. bE	E.BE	Brake transistor alarm detection	
E.USB	E.USB*	USB communication error	
E. 11	E.11	Opposite rotation deceleration error	
E. 13	E.13	Internal circuit error	

* If an E.ILF, E.PTC, E.PE2, E.CDO, E.IOH, E.SER, E.AIE or E.USB error occurs when using the FR-PU04, "Fault 14" is displayed on the FR-PU04.



A APPENDIX

A.1 Instructions for Compliance with the European Directives

A.1.1 EMC Directive

We have self-confirmed our inverters as products compliant to the EMC Directive (second environment of conforming standard EN61800-3) and placed the CE mark on the inverters.

Remarks

- | |
|---|
| <ul style="list-style-type: none">• First environment
Environment including residential buildings. Includes buildings directly connected without a transformer to the low voltage power supply network which supplies power to residential buildings.• Second environment
Environment including all buildings except buildings directly connected without a transformer to the low voltage power supply network which supplies power to residential buildings. |
|---|

A.1.2 Notes

Install the inverter (and if necessary optional radio interference suppression filters) and perform wiring according to the following instructions.

- The FR-A 700 EC inverters are equipped with a built-in EMC filter. Set the EMC filter valid (initial setting).
- Connect the inverter to an earthed power supply.
- Install a motor and a control cable written in the EMC Installation Manual (BCN-A21041-204) according to the instruction.
- The maximum cable length (shielded cable) between the frequency inverter and motor required to maintain the limiting values of the second environment is 5m when using the internal radio interference suppression filter.
- Make sure that the frequency inverter, if required (optional external) radio interference suppression filters and the motor are installed in compliance with generally recognised EMC installation regulations. It is not permitted to start up the device unless the EMC guidelines are complied with.

A.1.3 Low Voltage Directive

We have self-confirmed our inverters as products compliant to the Low Voltage Directive (Conforming standard EN 50178) and placed the CE mark on the inverters.

Outline of instructions

- Do not use a residual current operated protective device (RCD) as an electric shock protector without connecting the equipment to the earth. Connect the equipment to the earth securely.
- Wire the earth terminal independently. (Do not connect two or more cables to one terminal.)
- Use the cable sizes on *page 7* under the following conditions.
 - Ambient temperature: 40°C maximum
 - Wire installation: With conduits for 400V, 00380 or less
 - On wall without ducts or conduits for 400V, 00470 or more
 - If conditions are different from above, select appropriate wire according to EN60204 Appendix C TABLE 5.
- Use a tinned (plating should not include zinc) crimping terminal to connect the earth cable. When tightening the screw, be careful not to damage the threads.
- For use as a product compliant with the Low Voltage Directive, use PVC cable whose size is indicated on *page 7*.
- Use the moulded case circuit breaker and magnetic contactor which conform to the EN or IEC Standard.
- When using an earth leakage current breaker, use a residual current operated protective device (RCD) of type B (breaker which can detect both AC and DC.) If not, provide double or reinforced insulation between the inverter and other equipment, or put a transformer between the main power and inverter.
- Use the residual current operated protective device (RCD) of type B (breaker which can detect both AC and DC). However, be aware that also AC/DC sensitive earth leakage circuit breakers can be activated when turning the main power on and off and that this behaviour can be improved through the use of AC/DC sensitive earth leakage circuit breakers with adapted triggering curve designed for the inverter. If not, provide double or reinforced insulation between the inverter and other equipment, or put a transformer between the main power supply and inverter.



- Use the inverter under the conditions of overvoltage category II (usable regardless of the earth condition of the power supply), overvoltage category III (usable with the earthed-neutral system power supply) and pollution degree 2 or lower specified in IEC664.
 - To use the inverter FR-A 740 EC of 00930 or more (IP00) under the conditions of pollution degree 2, install it in the enclosure of IP 2X or higher.
 - To use the inverter FR-A 740 EC under the conditions of pollution degree 3, install it in the enclosure of IP54 or higher.
 - To use the inverter FR-A 740 EC of 00770 or less (IP20) outside of an enclosure in the environment of pollution degree 2, fix a fan cover with fan cover fixing screws enclosed.

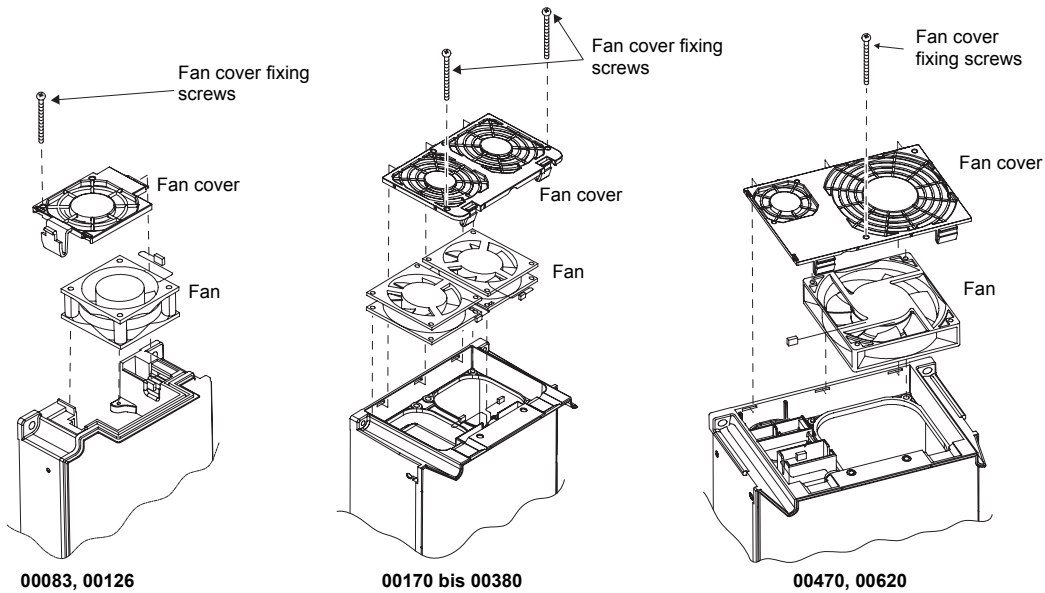

- On the input and output of the inverter, use cables of the type and size set forth in EN60204 Appendix C.
- The operating capacity of the relay outputs (terminal symbols A1, B1, C1, A2, B2, C2) should be 30VDC, 0.3A. (Relay outputs are basically isolated from the inverter internal circuit.)
- Control circuit terminals on page 4 are safely isolated from the main circuit.

Environment

	During Operation	In Storage	During Transportation
Ambient temperature	-10°C to +50°C (non-freezing) for selected overload capability 150 %, 200 % (initial setting) or 250 % -10°C to +40°C (non-freezing) for selected overload capability 120 % The maximum temperature depends on the setting of the parameter 570.	-20°C to +65°C	-20°C to +65°C
Ambient humidity	90% RH or less	90% RH or less	90% RH or less
Maximum altitude	1000m	1000m	10000m

A.1.4 Machine directive

The frequency inverter itself is not a machine in the spirit of the EU machine directive. The start up of the frequency inverter in a machine is prohibited so long until it has been confirmed that the entire machine complies with the provisions of Directive 89/392/EWG (machine directive).

A.2 Instructions for UL and cUL

(UL 508C, CSA C22.2 Nr.14)

A.2.1 Installation

The inverter FR-A 740 EC is UL-listed as a product for use in an enclosure.

Design an enclosure so that the inverter ambient temperature, humidity and atmosphere satisfy the specifications. (Refer to page 2)

Wiring protection

For installation in the United States, branch circuit protection must be provided in accordance with the National Electrical Code and any applicable provincial codes.

For installation in Canada, branch circuit protection must be provided in accordance with the Canada Electrical Code and any applicable provincial codes.

Provide the appropriate UL Listed Class RK5 oder class T fuses that are suitable for branch circuit protection in accordance with the table below.

FR-A 740-□□□□□-EC		00023	00038	00052	00083	00126	00170	00250	00310	00380	00470	00620	00770	00930	01160	01800
Rated voltage [V]		480V or more														
Rated current [A]	Without power factor improving reactor	6	10	15	20	30	40	70	80	90	110	150	175	200	250	300
	With power factor improving reactor	6	10	10	15	25	35	60	70	90	100	125	150	175	200	250

FR-A 740-□□□□□-EC		02160	02600	03250	03610	04320	04810	05470	06100	06830	07700	08660	09620	10940	12120
Rated voltage [V]		500V or more													
Rated current [A]	Without power factor improving reactor	—	—	—	—	—	—	—	—	—	—	—	—	—	—
	With power factor improving reactor	300	350	400	500	600	700	800	900	1000	1100	1200	1350	1500	1800

A.2.2 Wiring of the power supply and motor

For wiring the input (R/L1, S/L2, T/L3) and output (U, V, W) terminals of the inverter, use the UL-listed copper wires (rated at 75°C) and round crimping terminals. Crimp the crimping terminals with the crimping tool recommended by the terminal maker.

A.2.3 Short circuit ratings

- 01800 or less
Suitable for use in a circuit capable of delivering not more than 100kA rms symmetrical amperes, 528V maximum.
- 02160 or more
Suitable for use in a circuit capable of delivering not more than 100kA rms symmetrical amperes, 550V maximum.



A.2.4 Motor overload protection

The inverter FR-A 740 is equipped with an internal UL certified electronic motor overload protection.

When using the electronic thermal relay as motor overload protection, set the rated motor current to *Pr.9 Electronic thermal O/L relay*.

Electronic thermal relay function characteristic

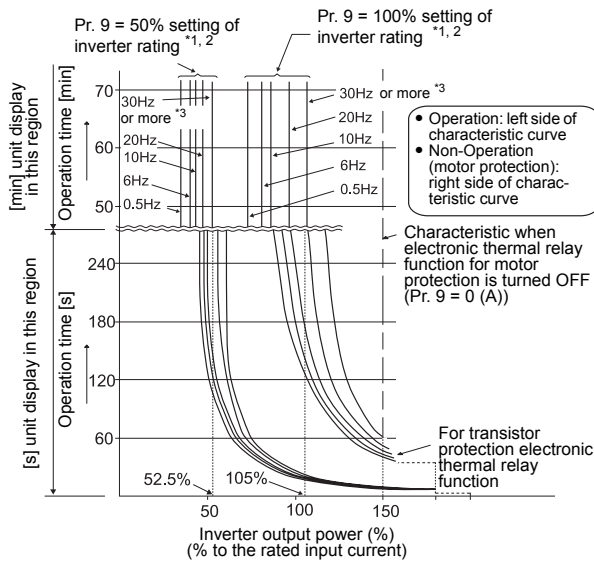

This function detects the overload (overheat) of the motor, stops the operation of the inverter's output transistor, and stops the output.

When using the Mitsubishi constant-torque motor set "1" or any of "13" to "18", "50", "53", "54" in Pr. 71. This provides a 100% continuous torque characteristic in the low-speed range. Set the rated current of the motor in Pr. 9.

*1 When a value 50% of the inverter rated output current (current value) is set in Pr. 9.

*2 The % value denotes the percentage to the inverter rated output current. It is not the percentage to the motor rated current.

*3 When you set the electronic thermal relay function dedicated to the Mitsubishi constant-torque motor, this characteristic curve applies to operation at 6Hz or higher.

CAUTION

- Protective function by electronic thermal relay function is reset by inverter power reset and reset signal input. Avoid unnecessary reset and power-off.
- When multiple motors are operated by a single inverter, protection cannot be provided by the electronic thermal relay function. Install an external thermal relay to each motor.
- When the difference between the inverter and motor capacities is large and the setting is small, the protective characteristics of the electronic thermal relay function will be deteriorated. In this case, use an external thermal relay.
- A special motor cannot be protected by the electronic thermal relay function. Use an external thermal relay.

About the CD ROM

- The copyright and other rights of this enclosed CD ROM all belong to Mitsubishi Electric Corporation.
- No part of this CD ROM may be copied or reproduced without the permission of Mitsubishi Electric Corporation.
- Specifications of this CD ROM are subject to change without notice.
- We are not responsible for any damages and lost earnings, etc. from use of this CD ROM.
- Microsoft, Windows, Microsoft Windows NT are registered trademarks of Microsoft Corporation in the United States and/or other countries. Adobe and Acrobat are registered trademarks of Adobe Systems Incorporated. Pentium is a registered trademark of Intel Corporation of the United States and/or other countries. Mac OS is a registered trademark of Apple Computer, Inc., U.S.A. PowerPC is a registered trademark of International Business Machines Corporation. Other company and product names herein are the trademarks and registered trademarks of their respective owners.

- Warranty
 - We do not provide a warranty against defects in this CD ROM and related documents.
 - We are not responsible to any loss resulting from use of this product

Acrobat Reader

For use of Acrobat Reader contained in this CD ROM, please follow use conditions established by Adobe System Incorporated.

⚠ WARNING

- This is a personal computer dedicated CD ROM. Do not attempt to play it on ordinary audio devices. The loud volume may damage hearing and speakers.

When playing the CD ROM on Windows OS

Operating environment

The following system is required to read instruction manuals contained in this CD ROM:

Item	Specifications
OS	Microsoft Windows 95 OSR 2.0, Windows 98 Second Edition, Windows Millennium Edition, Windows NT 4.0 with Service Pack 6, Windows 2000 with Service Pack 2, Windows XP Professional or Home Edition, Windows XP Tablet PC Edition
CPU	Intel Pentium processor
Memory	64MB of RAM
Hard disk	24MB of available hard disk space
CD ROM drive	Double speed or more (more than quadruple speed is recommended)
Monitor	800×600 dot or more
Application	Acrobat Reader 4.05 or more (This CD ROM contains Acrobat Reader 5.0. Install Acrobat Reader contained in the CD ROM or download Acrobat Reader from the internet)

Operating method of this CD ROM:

• Acrobat Reader 5.0 installation procedure

- ① Start Windows and place this CD ROM in the CD ROM drive.
- ② If Acrobat Reader is not installed in your computer, an installation screen of Acrobat Reader is automatically displayed.
- ③ Install according to the instruction of installation screen of Acrobat Reader.

Manual installation

- ① Start Windows and place this CD ROM in the CD ROM drive.
- ② Select a CD ROM drive (example: D drive) of "My computer" and click the right mouse button. Then, click "open" in the context menu.
- ③ Open "WINDOWS" folder in "ACROBAT" folder in the opened folder and execute AR505ENU.EXE.
- ④ Install according to the instruction of installation screen of Acrobat Reader.

• How to read instruction manual

- ① Start Windows and place this CD ROM in the CD ROM drive.
- ② "700 series documentation" PDF automatically opens.
- ③ Click a PDF file name of the manual you want to read in the "INSTRUCTION MANUAL" list.
- ④ PDF manual you clicked opens.

Manual opening of this CD ROM

- ① Start Windows and place this CD ROM in the CD ROM drive.
- ② Select a CD ROM drive (example: D drive) of "My computer" and click the right mouse button. Then, click "open" in the context menu.
- ③ Open "INDEX.PDF" in the opened folder
- ④ "700 series documentation" PDF opens. Operates according to the steps from Step ③ of "How to read instruction manual"

When playing this CD ROM on Macintosh OS

Item	Specifications
OS	Mac OS 8.6, 9.0.4, 9.1, or Mac OS X* (* Some features may not be available.)
CPU	PowerPC processor
Memory	64MB of RAM
Hard disk	24MB of available hard disk space
CD ROM drive	Double speed or more (more than quadruple speed is recommended)
Monitor	800×600 dot or more
Application	Acrobat Reader 4.05 or more (This CD ROM contains Acrobat Reader 5.0. Install Acrobat Reader contained in the CD ROM or download Acrobat Reader from the internet)

• Operating method of this CD ROM

- ① Start Macintosh and place this CD ROM in the CD ROM drive.
- ② Double click on the CD ROM icon on the desk top to open the CD ROM.
- ③ Open "MacOS" folder in "ACROBAT" folder in the opened folder and execute Acrobat Reader Installer.
- ④ Install according to the instruction of installation screen of Acrobat Reader.

• How to read instruction manuals

- ① Start Macintosh and place this CD ROM in the CD ROM drive.
- ② Double click on the CD ROM icon on the desk top to open the CD ROM.
- ③ Open "INDEX.PDF" in the opened folder
- ④ "700 series documentation" PDF opens.
- ⑤ Click a PDF file name of the manual you want to read in the "INSTRUCTION MANUAL" list.
- ⑥ PDF manual you clicked opens.

HEADQUARTERS

MITSUBISHI ELECTRIC EUROPE
EUROPE B.V.
German Branch
Gothaer Straße 8
D-40880 Ratingen
Phone: +49 (0)2102 486-0
Fax: +49 (0)2102 486-1120
e mail: megfamail@meg.mee.com

MITSUBISHI ELECTRIC EUROPE B.V.
FRANCE
French Branch
25, Boulevard des Bouvets
F-92741 Nanterre Cedex
Phone: +33 1 55 68 55 68
Fax: +33 1 55 68 56 85
e mail: factory.automation@fra.mee.com

MITSUBISHI ELECTRIC EUROPE B.V.
IRELAND
Irish Branch
Westgate Business Park, Ballymount
IRL-Dublin 24
Phone: +353 (0) 1 / 419 88 00
Fax: +353 (0) 1 / 419 88 90
e mail: sales.info@meir.mee.com

MITSUBISHI ELECTRIC EUROPE B.V.
ITALY
Italian Branch
Via Paracelso 12
I-20041 Agrate Brianza (MI)
Phone: +39 039 60 53 1
Fax: +39 039 60 53 312
e mail: factory.automation@it.mee.com

MITSUBISHI ELECTRIC EUROPE B.V.
SPAIN
Spanish Branch
Carretera de Rubí 76-80
E-08190 Sant Cugat del Vallés
Phone: +34 9 3 565 3160
Fax: +34 9 3 589 1579
e mail: industrial@sp.mee.com

MITSUBISHI ELECTRIC EUROPE B.V.
UK
UK Branch
Travellers Lane
GB-Hatfield Herts. AL10 8 XB
Phone: +44 (0) 1707 / 27 61 00
Fax: +44 (0) 1707 / 27 86 95
e mail: automation@meuk.mee.com

MITSUBISHI ELECTRIC CORPORATION
JAPAN
Office Tower "Z" 14 F
8-12,1 chome, Harumi Chuo-Ku
Tokyo 104-6212
Phone: +81 3 622 160 60
Fax: +81 3 622 160 75

MITSUBISHI ELECTRIC AUTOMATION
USA
500 Corporate Woods Parkway
Vernon Hills, IL 60061
Phone: +1 847 478 21 00
Fax: +1 847 478 22 83

EUROPEAN REPRESENTATIVES

GEVA AUSTRIA
Wiener Straße 89
AT-2500 Baden
Phone: +43 (0)2252 / 85 55 20
Fax: +43 (0)2252 / 488 60
e mail: office@geva.at

TEHNIKON BELARUS
Oktjabrskaya 16/5, Ap 704
BY-220030 Minsk
Phone: +375 (0)17 / 2104626
Fax: +375 (0)17 / 2104626
e mail: tehnikon@belsonet.net

Koning & Hartman b.v. BELGIUM
Researchpark Zellik
Pontbeeklaan 43
BE-1731 Brussels
Phone: +32 (0)2 / 467 17 51
Fax: +32 (0)2 / 467 17 45
e mail: info@koningenhartman.com

AKNATHON BULGARIA
4, A. Ljapchev Blvd.
BG-1756 Sofia
Phone: +359 (0)2 / 97 44 058
Fax: +359 (0)2 / 97 44 061
e mail: —

AutoCont CZECH REPUBLIC
Control Systems s.r.o.
Nemocnicni 12
CZ-70200 Ostrava 2
Phone: +420 59 / 6152 111
Fax: +420 59 / 6152 562
e mail: consys@autocont.cz

louis poulsen DENMARK
industri & automation
Geminivej 32
DK-2670 Greve
Phone: +45 (0)43 / 95 95 95
Fax: +45 (0)43 / 95 95 91
e mail: lpia@lpmail.com

UTU Elektrotehnika AS ESTONIA
Pärnu mnt.160i
EE-10621 Tallinn
Phone: +372 (0)6 / 51 72 80
Fax: +372 (0)6 / 51 72 88
e mail: utu@utu.ee

UTU POWEL OY FINLAND
Box 236
FIN-28101 Pori
Phone: +358 (0)2 / 550 800
Fax: +358 (0)2 / 550 8841
e mail: tehoelektronikka@urhotuominen.fi

UTECO A.B.E.E. GREECE
5, Mavrogenous Str.
GR-18542 Piraeus
Phone: +302 (0)10 / 42 10 050
Fax: +302 (0)10 / 42 12 033
e mail: uteco@uteco.gr

Meltrade Automatika Kft. HUNGARY
55, Harmat St.
HU-1105 Budapest
Phone: +36 (0)1 / 2605 602
Fax: +36 (0)1 / 2605 602
e mail: office@meltrade.hu

SIA POWEL LATVIA
Lienes iela 28
LV-1009 Riga
Phone: +371 784 2280
Fax: +371 784 2281
e mail: utu@utu.lv

UAB UTU POWEL LITHUANIA
Savanoriu Pr. 187
LT-2053 Vilnius
Phone: +370 (0)52323-101
Fax: +370 (0)52322-980
e mail: powel@utu.lt

EUROPEAN REPRESENTATIVES

Intehsis Srl MOLDOVA
Bld. Traian 23/1
MD-2060 Kishinev
Phone: +373 (0)22/ 66 4242
Fax: +373 (0)22/ 66 4280
e mail: intehsis@mdl.net

Koning & Hartman b.v. NETHERLANDS
Donauweg 2 B
NL-1000 AK Amsterdam
Phone: +31 (0)20 / 587 76 00
Fax: +31 (0)20 / 587 76 05
e mail: info@koningenhartman.com

Beijer Electronics AS NORWAY
Teglværksveien 1
NO-3002 Drammen
Phone: +47 (0)32 / 24 30 00
Fax: +47 (0)32 / 84 85 77
e mail: info@beijer.no

MPL Technology Sp. z o.o. POLAND
ul. Sliczna 36
PL-31-444 Kraków
Phone: +48 (0)12 / 632 28 85
Fax: +48 (0)12 / 632 47 82
e mail: krakow@mpl.pl

Sirius Trading & Services srl ROMANIA
Str. Biharia Nr. 67-77
RO-013981 Bucuresti 1
Phone: +40 (0) 21 / 201 1146
Fax: +40 (0) 21 / 201 1148
e mail: sirius@siriustrading.ro

CRAFT SERBIA AND MONTENEGRO
Consulting & Engineering d.o.o.
Branka Krsmanovica Str. 43-V
18000 Nis
Phone: +381 (0)18 / 531 226
Fax: +381 (0)18 / 532 334
e mail: craft@bankerinter.net

INEA SR d.o.o. SERBIA AND MONTENEGRO
Karadjordjeva 12/260
113000 Smederevo
Phone: +381 (0)26 / 617 163
Fax: +381 (0)26 / 617 163
e mail: vladstoj@yubc.net

AutoCont Control s.r.o. SLOVAKIA
Radlinského 47
SK-02601 Dolný Kubín
Phone: +421 435868210
Fax: +421 435868210
e mail: info@autocontcontrol.sk

INEA d.o.o. SLOVENIA
Stegne 11
SI-1000 Ljubljana
Phone: +386 (0)1 513 8100
Fax: +386 (0)1 513 8170
e mail: inea@inea.si

Beijer Electronics AB SWEDEN
Box 426
S-20124 Malmö
Phone: +46 (0)40 / 35 86 00
Fax: +46 (0)40 / 35 86 02
e mail: info@beijer.de

ECONOTEC AG SWITZERLAND
Postfach 282
CH-8309 Nürensdorf
Phone: +41 (0)1 / 838 48 11
Fax: +41 (0)1 / 838 48 12
e mail: info@econotec.ch

GTS TURKEY
Darülaceze Cad. No. 43A KAT: 2
TR-80270 Okmeydani-Istanbul
Phone: +90 (0)212 / 320 1640
Fax: +90 (0)212 / 320 1649
e mail: gts@turk.net

CSC Automation Ltd UKRAINE
15, M. Raskova St., Fl. 10, Office 1010
UA-02002 Kiev
Phone: +380 (0)44 / 494 33 55
Fax: +380 (0)44 / 494 33 66
e mail: csc-a@csc-a.kiev.ua

EURASIAN REPRESENTATIVES

Kazpromautomatiks Ltd. KAZAKHSTAN
2, Scladskaya Str.
KAZ-470046 Karaganda
Phone: +7 3212 50 11 50
Fax: +7 3212 50 11 50
e mail: info@kpakz.com

Avtomatika Sever Ltd. RUSSIA
Lva Tolstogo Str. 7, Off. 311
RU-197376 St Petersburg
Phone: +7 812 / 718 32 38
Fax: +7 812 / 718 32 39
e mail: as@avtsev.spb.ru

CONSUS RUSSIA
Promyshlennaya St. 42
RU-198099 St Petersburg
Phone: +7 812 / 325 3653
Fax: +7 812 / 147 2055
e mail: consus@consus.spb.ru

Electrotechnical Systems Siberia RUSSIA
Shetinkina St. 33, Office 116
RU-630088 Novosibirsk
Tél: +7 3832 / 11 95 98
Fax: +7 3832 / 11 95 98
e mail: info@eltechsystems.ru

ELEKTROSTYLE RUSSIA
Krasnij Prospekt 220-1, Office 312
RU-630049 Novosibirsk
Phone: +7 3832 / 10 6618
Fax: +7 3832 / 10 6626
e mail: info@estl.ru

ELEKTROSTYLE RUSSIA
Poslannikov Per., 9, Str.1
RU-107005 Moscow
Phone: +7 095 / 542-4323
Fax: +7 095 / 956-7526
e mail: info@estl.ru

ICOS RUSSIA
Ryazanskij Prospekt, 8A, Office 100
RU-109428 Moscow
Phone: +7 095 / 232 0207
Fax: +7 095 / 232 0327
e mail: mail@icos.ru

STC Drive Technique RUSSIA
Poslannikov per., 9, str.1
RU-107005 Moscow
Phone: +7 095 / 786 21 00
Fax: +7 095 / 786 21 01
e mail: info@privod.ru

MIDDLE EAST REPRESENTATIVE

SHERF Motion Techn. Ltd ISRAEL
Rehov Hamerkava 19
IL-58851 Holon
Phone: +972 (0)3 / 559 54 62
Fax: +972 (0)3 / 556 01 82
e mail: —

AFRICAN REPRESENTATIVE

CBI Ltd SOUTH AFRICA
Private Bag 2016
ZA-1600 Isando
Phone: +27 (0)11 / 928 2000
Fax: +27 (0)11 / 392 2354
e mail: cbi@cbi.co.za