



# INVERTER

## FR-E700

# INSTALLATION GUIDELINE

FR-E740-016(SC) to 300(SC)-EC

FR-E720S-008(SC) to 110(SC)-EC

Thank you for choosing this Mitsubishi Inverter.

Please read through this Installation Guideline and a CD-ROM enclosed to operate this inverter correctly. Do not use this product until you have a full knowledge of the equipment, safety information and instructions.

Please forward this Installation Guideline and the CD-ROM to the end user.

### CONTENTS

<b>[1]</b>	<b>PRODUCT CHECKING AND PARTS IDENTIFICATION .....</b>	<b>1</b>
<b>[2]</b>	<b>OUTLINE DIMENSION DRAWINGS .....</b>	<b>3</b>
<b>[3]</b>	<b>WIRING .....</b>	<b>4</b>
<b>[4]</b>	<b>PRECAUTIONS FOR USE OF THE INVERTER .....</b>	<b>12</b>
<b>[5]</b>	<b>FAILSAFE OF THE SYSTEM WHICH USES THE INVERTER</b>	<b>14</b>
<b>[6]</b>	<b>PARAMETER LIST .....</b>	<b>15</b>
<b>[7]</b>	<b>TROUBLESHOOTING.....</b>	<b>19</b>

*E* 700

This Installation Guideline provides handling information and precautions for use of the equipment. Please forward this Installation Guideline to the end user.

**This section is specifically about safety matters**

Do not attempt to install, operate, maintain or inspect the inverter until you have read through the Installation Guideline and appended documents carefully and can use the equipment correctly. Do not use this product until you have a full knowledge of the equipment, safety information and instructions. In this Installation Guideline, the safety instruction levels are classified into "WARNING" and "CAUTION".

**WARNING** Incorrect handling may cause hazardous conditions, resulting in death or severe injury.

**CAUTION** Incorrect handling may cause hazardous conditions, resulting in medium or slight injury, or may cause only material damage.

The **CAUTION** level may even lead to a serious consequence according to conditions. Both instruction levels must be followed because these are important to personal safety.

**1. Electric Shock Prevention**

**WARNING**

- While power is ON or when the inverter is running, do not open the front cover. Otherwise you may get an electric shock.
- Do not run the inverter with the front cover or wiring cover removed. Otherwise you may access the exposed high-voltage terminals or the charging part of the circuitry and get an electric shock.
- Even if power is OFF, do not remove the front cover except for wiring or periodic inspection. You may accidentally touch the charged inverter circuits and get an electric shock.
- Before wiring or inspection, power must be switched OFF. To confirm that, LED indication of the operation panel must be checked. (It must be OFF.) Any person who is involved in wiring or inspection shall wait for at least 10 minutes after the power supply has been switched OFF and check that there are no residual voltage using a tester or the like. The capacitor is charged with high voltage for some time after power OFF, and it is dangerous.
- This inverter must be earthed (grounded). Earthing (grounding) must conform to the requirements of national and local safety regulations and electrical code (NEC section 250, IEC 536 class 1 and other applicable standards). A neutral-point earthed (grounded) power supply for 400V class inverter in compliance with EN standard must be used.
- Any person who is involved in wiring or inspection of this equipment shall be fully competent to do the work.
- The inverter must be installed before wiring. Otherwise, you may get an electric shock or be injured.
- Setting dial and key operations must be performed with dry hands to prevent an electric shock. Otherwise you may get an electric shock.
- Do not subject the cables to scratches, excessive stress, heavy loads or pinching. Otherwise you may get an electric shock.
- Do not change the cooling fan while power is ON. It is dangerous to change the cooling fan while power is ON.
- Do not touch the printed circuit board or handle the cables with wet hands. Otherwise you may get an electric shock.
- When measuring the main circuit capacitor capacity, the DC voltage is applied to the motor for 1s at powering OFF. Never touch the motor terminal, etc. right after powering OFF to prevent an electric shock.

**2. Fire Prevention**

**CAUTION**

- Inverter must be installed on a nonflammable wall without holes (so that nobody touches the inverter heatsink on the rear side, etc.). Mounting it to or near flammable material can cause a fire.
- If the inverter has become faulty, the inverter power must be switched OFF. A continuous flow of large current could cause a fire.
- When using a brake resistor, a sequence that will turn OFF power when a fault signal is output must be configured. Otherwise the brake resistor may overheat due to damage of the brake transistor and possibly cause a fire.
- Do not connect a resistor directly to the DC terminals P/+ and N/-. Doing so could cause a fire.

**3. Injury Prevention**

**CAUTION**

- The voltage applied to each terminal must be the ones specified in the Instruction Manual. Otherwise burst, damage, etc. may occur.
- The cables must be connected to the correct terminals. Otherwise burst, damage, etc. may occur.
- Polarity must be correct. Otherwise burst, damage, etc. may occur.
- While power is ON or for some time after power-OFF, do not touch the inverter as they will be extremely hot. Doing so can cause burns.

**4. Additional Instructions**

Also the following points must be noted to prevent an accidental failure, injury, electric shock, etc.

**(1) Transportation and Mounting**

**CAUTION**

- The product must be transported in correct method that corresponds to the weight. Failure to do so may lead to injuries.
- Do not stack the boxes containing inverters higher than the number recommended.
- The product must be installed to the position where withstands the weight of the product according to the information in the Instruction Manual.
- Do not install or operate the inverter if it is damaged or has parts missing.
- When carrying the inverter, do not hold it by the front cover or setting dial; it may fall off or fail.
- Do not stand or rest heavy objects on the product.
- The inverter mounting orientation must be correct.
- Foreign conductive objects must be prevented from entering the inverter. That includes screws and metal fragments or other flammable substance such as oil.
- As the inverter is a precision instrument, do not drop or subject it to impact.
- The inverter must be used under the following environment. Otherwise the inverter may be damaged.

Environment	Surrounding air temperature	-10°C to +50°C (non-freezing)
	Ambient humidity	90%RH or less (non-condensing)
	Storage temperature	-20°C to +65°C *1
	Atmosphere	Indoors (free from corrosive gas, flammable gas, oil mist, dust and dirt)
	Altitude/vibration	Maximum 1000m above sea level for standard operation. After that derate by 3% for every extra 500m up to 2500m (91%). 5.9m/s <sup>2</sup> or less at 10 to 55Hz (directions of X, Y, Z axes)

\*1 Temperature applicable for a short time, e.g. in transit.

## (2) Wiring

### CAUTION

- Do not install a power factor correction capacitor or surge suppressor/capacitor type filter on the inverter output side. These devices on the inverter output side may be overheated or burn out.
- The connection orientation of the output cables U, V, W to the motor affects the rotation direction of the motor.

## (3) Trial run

### CAUTION

- Before starting operation, each parameter must be confirmed and adjusted. A failure to do so may cause some machines to make unexpected motions.

## (4) Usage

### WARNING

- Any person must stay away from the equipment when the retry function is set as it will restart suddenly after trip.
- Since pressing  key may not stop output depending on the function setting status, separate circuit and switch that make an emergency stop (power OFF, mechanical brake operation for emergency stop, etc.) must be provided.
- OFF status of the start signal must be confirmed before resetting the inverter fault. Resetting inverter alarm with the start signal ON restarts the motor suddenly.
- The inverter must be used for three-phase induction motors. Connection of any other electrical equipment to the inverter output may damage the equipment.
- Do not modify the equipment.
- Do not perform parts removal which is not instructed in this manual. Doing so may lead to fault or damage of the product.

### CAUTION

- The electronic thermal relay function does not guarantee protection of the motor from overheating. It is recommended to install both an external thermal and PTC thermistor for overheat protection.
- Do not use a magnetic contactor on the inverter input for frequent starting/stopping of the inverter. Otherwise the life of the inverter decreases.
- The effect of electromagnetic interference must be reduced by using a noise filter or by other means. Otherwise nearby electronic equipment may be affected.
- Appropriate measures must be taken to suppress harmonics. Otherwise power supply harmonics from the inverter may heat/damage the power factor correction capacitor and generator.
- When driving a 400V class motor by the inverter, the motor must be an insulation-enhanced motor or measures must be taken to suppress surge voltage. Surge voltage attributable to the wiring constants may occur at the motor terminals, deteriorating the insulation of the motor.
- When parameter clear or all parameter clear is performed, the required parameters must be set again before starting operations because all parameters return to the initial value.
- The inverter can be easily set for high-speed operation. Before changing its setting, the performances of the motor and machine must be fully examined.
- Stop status cannot be hold by the inverter's brake function. In addition to the inverter's brake function, a holding device must be installed to ensure safety.
- Before running an inverter which had been stored for a long period, inspection and test operation must be performed.
- For prevention of damage due to static electricity, nearby metal must be touched before touching this product to eliminate static electricity from your body.

## (5) Emergency stop

### CAUTION

- A safety backup such as an emergency brake must be provided to prevent hazardous condition to the machine and equipment in case of inverter failure.
- When the breaker on the inverter input side trips, the wiring must be checked for fault (short circuit), and internal parts of the inverter for a damage, etc. The cause of the trip must be identified and removed before turning ON the power of the breaker.
- When any protective function is activated, appropriate corrective action must be taken, and the inverter must be reset before resuming operation.

## (6) Maintenance, inspection and parts replacement

### CAUTION

- Do not carry out a megger (insulation resistance) test on the control circuit of the inverter. It will cause a failure.

## (7) Disposal

### CAUTION

- The inverter must be treated as industrial waste.

### General instruction

Many of the diagrams and drawings in this Installation Guideline show the inverter without a cover or partially open for explanation. Never operate the inverter in this manner. The cover must be always reinstalled and the instruction in this Installation Guideline must be followed when operating the inverter.

# 1 PRODUCT CHECKING AND PARTS IDENTIFICATION

Unpack the inverter and check the capacity plate on the front cover and the rating plate on the inverter side face to ensure that the product agrees with your order and the inverter is intact.

## ● Inverter model

FR - E740 - 095    - EC

Symbol	Voltage class
E740	Three-phase 400V class
E720S	Single-phase 200V class

Displays the rated current

Symbol	Control circuit terminal specification
No symbol	Standard control circuit terminal (screw type)
SC	Safety stop function model

## ● Capacity plate

Capacity plate	
FR-E740-095-EC	← Inverter model
SERIAL: XXXXXX	← Serial number

## ● Rating plate

Rating plate	
Inverter model	MITSUBISHI INVERTER MODEL: FR-E740-095-EC
Input rating	INPUT: XXXXX
Output rating	OUTPUT: XXXXX
Serial number	SERIAL: _____
	(PASSED)

## ● Installation of the inverter

Enclosure surface mounting

Remove the front cover and wiring cover to fix the inverter to the surface.

● FR-E720S-008(SC) to 030(SC)

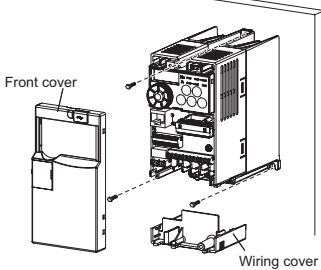

● FR-E740-016(SC) or more  
● FR-E720S-050(SC) or more

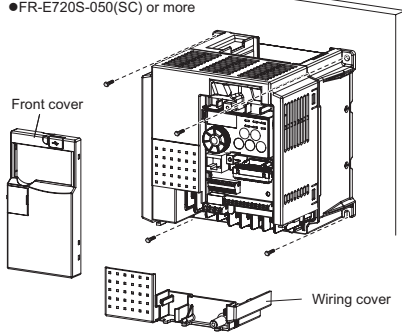

## NOTE

- When encasing multiple inverters, install them in parallel as a cooling measure.
- When using the inverters at the surrounding air temperature of 40°C or less, the inverters can be installed without any clearance between them (0cm clearance). When surrounding air temperature exceeds 40°C, clearances between the inverters should be 1cm or more (5cm or more for the FR-E740-120(SC) or more).
- Install the inverter vertically.

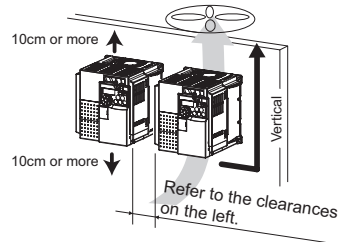

● General Precaution

The bus capacitor discharge time is 10 minutes. Before starting wiring or inspection, switch power OFF, wait for more than 10 minutes, and check for residual voltage between terminal P/+ and N/- with a meter etc., to avoid a hazard of electrical shock.

● Environment

Before installation, check that the environment meets following specifications.

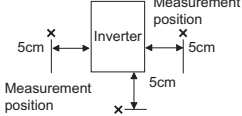
<p><b>Surrounding air temperature</b></p>	<p>-10°C to +50°C (non-freezing)</p> 
<p><b>Ambient humidity</b></p>	<p>90% RH or less (non-condensing)</p>
<p><b>Storage temperature</b></p>	<p>-20°C to +65°C (Temperature applicable for a short time, e.g. in transit.)</p>
<p><b>Ambience</b></p>	<p>Indoors (free from corrosive gas, flammable gas, oil mist, dust and dirt)</p>
<p><b>Altitude, vibration</b></p>	<p>Maximum 1,000m above sea level. After that derate by 3% for every extra 500m up to 2500m (91%). 5.9m/s<sup>2</sup> or less at 10 to 55Hz (directions of X, Y, Z axes)</p>



**Note**

- Install the inverter on a strong surface securely and vertically with bolts.
- Leave enough clearances and take cooling measures.
- Avoid places where the inverter is subjected to direct sunlight, high temperature and high humidity.
- Install the inverter on a non-combustible wall surface.

## 2 OUTLINE DIMENSION DRAWINGS

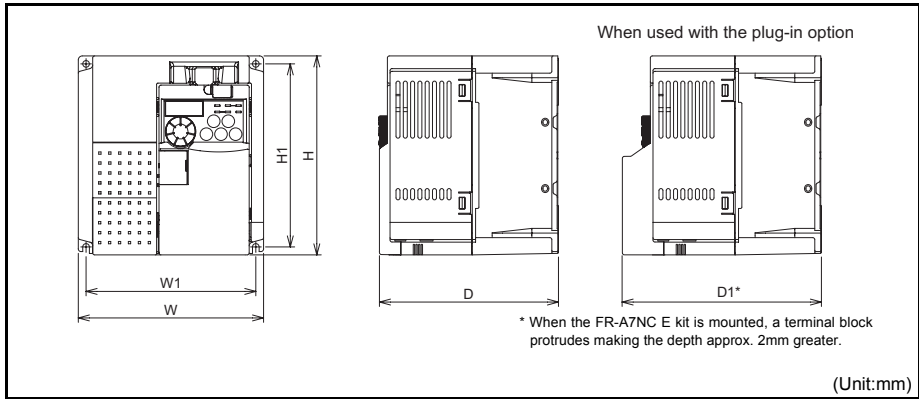

### (1) Standard control circuit terminal model

#### • Three-phase 400V class

Inverter Model	W	W1	H	H1	D	D1
FR-E740-016	140	128	150	138	114	129.1
FR-E740-026					135	150.1
FR-E740-040						
FR-E740-060						
FR-E740-095					220	208
FR-E740-120						
FR-E740-170						
FR-E740-230						
FR-E740-300		195			190	205.1

#### • Single-phase 200V class

Inverter Model	W	W1	H	H1	D	D1
FR-E720S-008	68	56	128	118	80.5	95.6
FR-E720S-015					142.5	157.6
FR-E720S-030						
FR-E720S-050	108	96	150	138	135.5	150.6
FR-E720S-080					161	176.1
FR-E720S-110					140	128

### (2) Safety stop function model

#### • Three-phase 400V class

Inverter Model	W	W1	H	H1	D	D1
FR-E740-016SC	140	128	150	138	120	141.6
FR-E740-026SC					141	162.6
FR-E740-040SC						
FR-E740-060SC						
FR-E740-095SC					220	208
FR-E740-120SC						
FR-E740-170SC						
FR-E740-230SC						
FR-E740-300SC		195			196	217.6

#### • Single-phase 200V class

Inverter Model	W	W1	H	H1	D	D1
FR-E720S-008SC	68	56	128	118	86.5	108.1
FR-E720S-015SC					148.5	170.1
FR-E720S-030SC						
FR-E720S-050SC	108	96	150	138	141.5	163.1
FR-E720S-080SC					167	188.6
FR-E720S-110SC					140	128

# 3 WIRING

## 3.1 Terminal connection diagram

### (1) Standard control circuit terminal model

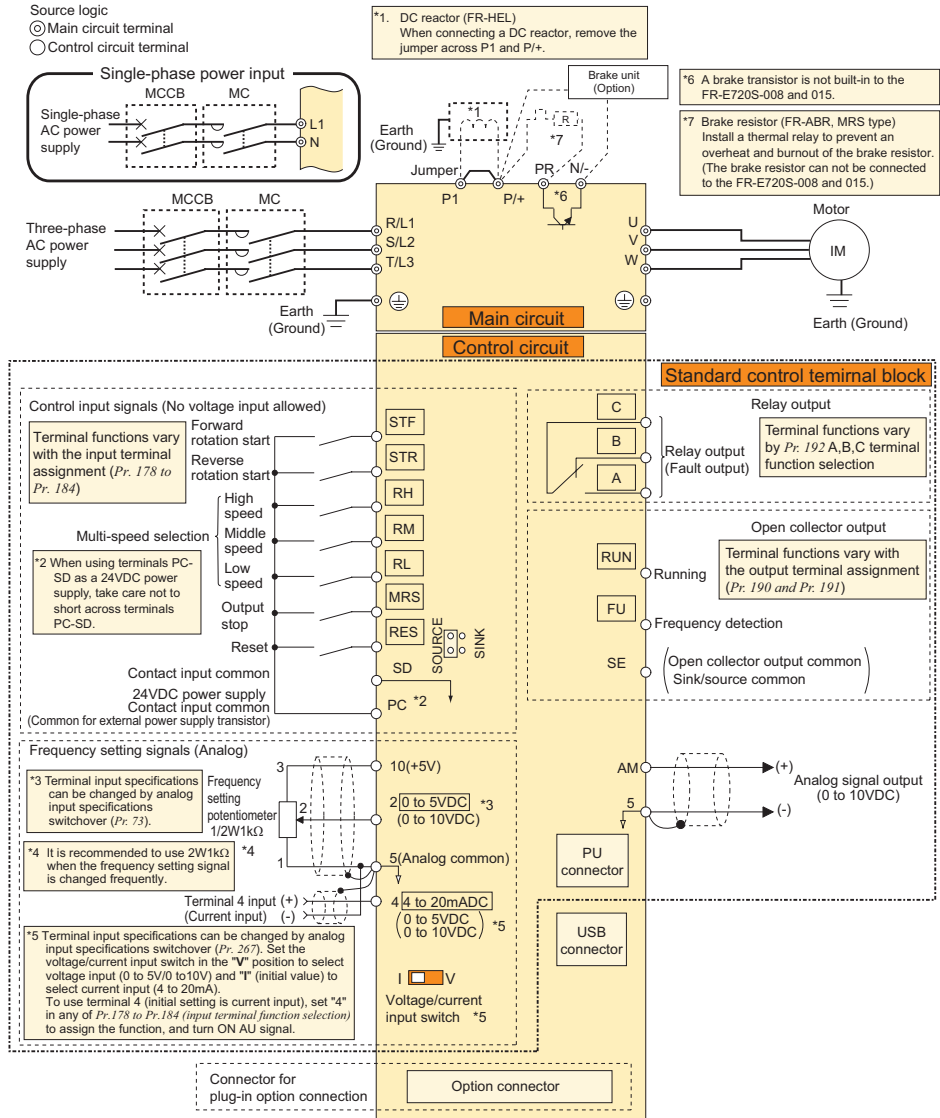

### NOTE

- To prevent a malfunction caused by noise, separate the signal cables more than 10cm from the power cables. Also separate the main circuit wire of the input side and the output side.
- After wiring, wire offcuts must not be left in the inverter.
- Wire offcuts can cause an alarm, failure or malfunction. Always keep the inverter clean. When drilling mounting holes in an enclosure etc., take care not to allow chips and other foreign matter to enter the inverter.
- The output of the single-phase power input model is three-phase 200V.

(2) Safety stop function model

Source logic

- ⊙ Main circuit terminal
- Control circuit terminal

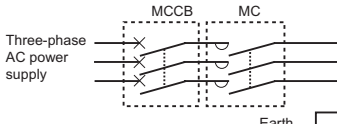
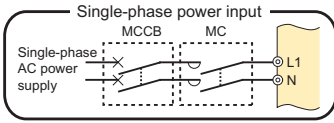

\*1. DC reactor (FR-HEL)  
When connecting a DC reactor, remove the jumper across P1 and P/+.

\*6 A brake transistor is not built-in to the FR-E720S-008SC and 015SC.

\*7 Brake resistor (FR-ABR, MRS type)  
Install a thermal relay to prevent an overheat and burnout of the brake resistor. (The brake resistor can not be connected to the FR-E720S-008SC and 015SC.)

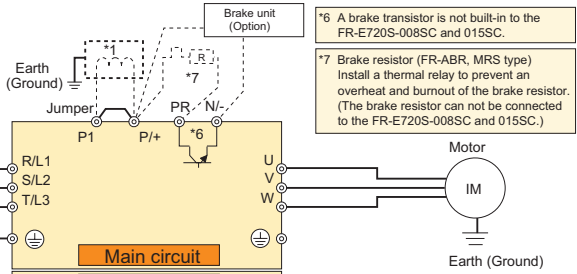

Control input signals (No voltage input allowed)

Terminal functions vary with the input terminal assignment (Pr. 178 to Pr. 182 and Pr. 184)

Multi-speed selection

\*2 When using terminals PC-SD as a 24VDC power supply, take care not to short across terminals PC-SD.

Contact input common 24VDC power supply (Common for external power supply transistor) Safety stop input common terminal

Safety stop input (Channel 1)  
Safety stop input (Channel 2)  
Shorting wire

Frequency setting signals (Analog)

\*3 Terminal input specifications can be changed by analog input specifications switchover (Pr. 73).

\*4 It is recommended to use 2W1kΩ when the frequency setting signal is changed frequently.

\*5 Terminal input specifications can be changed by analog input specifications switchover (Pr. 267). Set the voltage/current input switch in the "V" position to select voltage input (0 to 5V/0 to 10V) and "I" (initial value) to select current input (4 to 20mA). To use terminal 4 (initial setting is current input), set "4" in any of Pr.178 to Pr.184 (input terminal function selection) to assign the function, and turn ON AU signal.

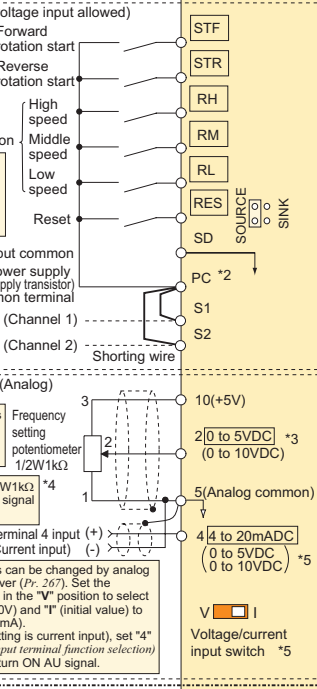

Safety stop function model

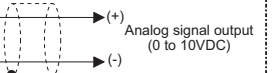
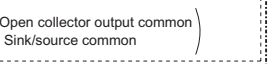
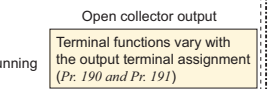
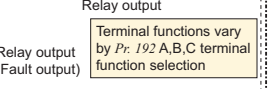

NOTE

- To prevent a malfunction caused by noise, separate the signal cables more than 10cm from the power cables. Also separate the main circuit wire of the input side and the output side.
- After wiring, wire offcuts must not be left in the inverter.
- Wire offcuts can cause an alarm, failure or malfunction. Always keep the inverter clean. When drilling mounting holes in an enclosure etc., take care not to allow chips and other foreign matter to enter the inverter.
- The output of the single-phase power input model is three-phase 200V.



### 3.2 Main circuit terminal specifications

#### 3.2.1 Terminal arrangement of the main circuit terminal, power supply and the motor wiring

● **Three-phase 400V class**

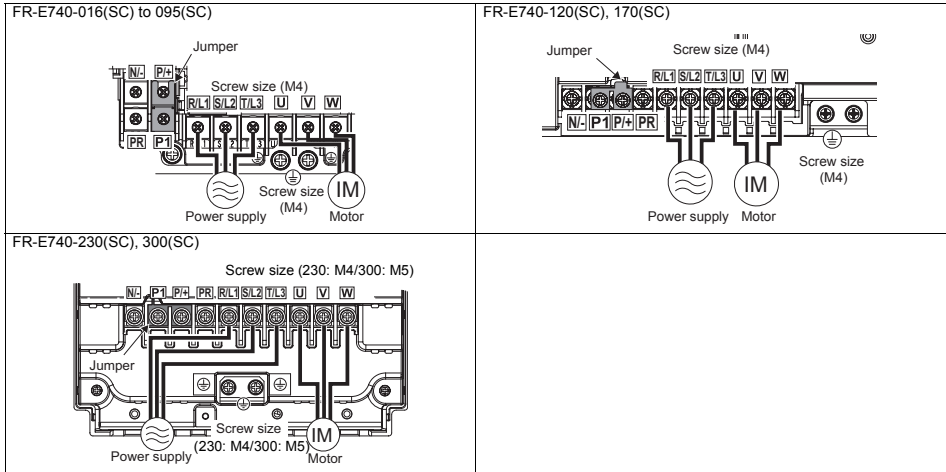

● **Single-phase 200V class**

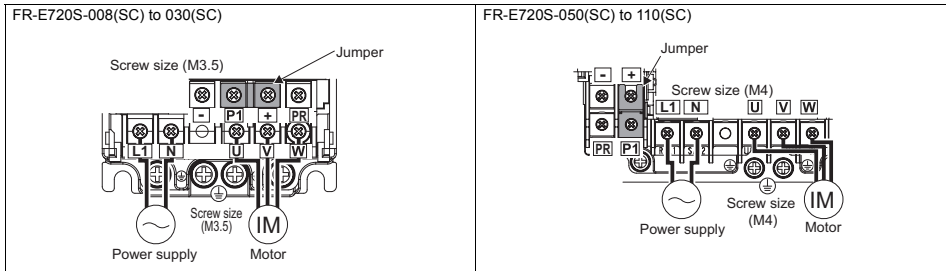

**NOTE**

- Make sure the power cables are connected to the R/L1, S/L2, T/L3. Never connect the power cable to the U, V, W of the inverter. (Phase need not be matched.) Doing so will damage the inverter.
- Connect the motor to U, V, W. Turning ON the forward rotation switch (signal) at this time rotates the motor counterclockwise when viewed from the load shaft.

### 3.2.2 Cables and wiring length

#### (1) Cable sizes etc., of the main control circuit terminals and earth (ground) terminals

Select the recommended cable size to ensure that a voltage drop will be 2% max.

If the wiring distance is long between the inverter and motor, a main circuit cable voltage drop will cause the motor torque to decrease especially at the output of a low frequency.

The following table indicates a selection example for the wiring length of 20m.

● **Three-phase 400V class (when input power supply is 440V)**

Applicable Inverter Model	Terminal Screw Size <sup>+4</sup>	Tightening Torque N·m	Crimping Terminal		Cable Size								
					HIV Cables, etc. (mm <sup>2</sup> ) <sup>+1</sup>			AWG <sup>+2</sup>			PVC Cables, etc. (mm <sup>2</sup> ) <sup>+3</sup>		
					R/L1 S/L2 T/L3	U, V, W	Earthing cable	R/L1 S/L2 T/L3	U, V, W	Earthing cable	R/L1 S/L2 T/L3	U, V, W	Earthing cable
FR-E740-016(SC) to 095(SC)	M4	1.5	2-4	2-4	2	2	2	14	14	2.5	2.5	2.5	
FR-E740-120(SC)	M4	1.5	5.5-4	2-4	3.5	2	3.5	12	14	4	2.5	4	
FR-E740-170(SC)	M4	1.5	5.5-4	5.5-4	3.5	3.5	3.5	12	12	4	4	4	
FR-E740-230(SC)	M4	1.5	5.5-4	5.5-4	5.5	5.5	8	10	10	6	6	10	
FR-E740-300(SC)	M5	2.5	8-5	8-5	8	8	8	8	8	10	10	10	

● **Single-phase 200V class (when input power supply is 220V)**

Applicable Inverter Model	Terminal Screw Size <sup>+4</sup>	Tightening Torque N·m	Crimping Terminal		Cable Size								
					HIV Cables, etc. (mm <sup>2</sup> ) <sup>+1</sup>			AWG <sup>+2</sup>			PVC Cables, etc. (mm <sup>2</sup> ) <sup>+3</sup>		
					L1 N	U, V, W	Earthing cable	L1 N	U, V, W	Earthing cable	L1 N	U, V, W	Earthing cable
FR-E720S-008(SC) to 030(SC)	M3.5	1.2	2-3.5	2-3.5	2	2	2	14	14	2.5	2.5	2.5	
FR-E720S-050(SC)	M4	1.5	2-4	2-4	2	2	2	14	14	2.5	2.5	2.5	
FR-E720S-080(SC)	M4	1.5	2-4	2-4	2	2	2	14	14	2.5	2.5	2.5	
FR-E720S-110(SC)	M4	1.5	5.5-4	2-4	3.5	2	2	12	14	4	2.5	2.5	

- \*1 The cable size is that of the cable (HIV cable (600V class 2 vinyl-insulated cable) etc.) with continuous maximum permissible temperature of 75°C. Assumes that the surrounding air temperature is 50°C or less and the wiring distance is 20m or less.
- \*2 The recommended cable size is that of the cable (THHW cable) with continuous maximum permissible temperature of 75°C. Assumes that the surrounding air temperature is 40°C or less and the wiring distance is 20m or less.  
(Selection example for use mainly in the United States.)
- \*3 The recommended cable size is that of the cable (THHW cable) with continuous maximum permissible temperature of 70°C. Assumes that the surrounding air temperature is 40°C or less and the wiring distance is 20m or less.  
(Selection example for use mainly in Europe.)
- \*4 The terminal screw size indicates the terminal size for R/L1, S/L2, T/L3, U, V, W, PR, P/+, N/-, P1 and a screw for earthing (grounding).  
(For single-phase power input, the terminal screw size indicates the size of terminal screw for L1, N, U, V, W, PR, +, -, P1 and a screw for earthing (grounding).)



**NOTE**

- Tighten the terminal screw to the specified torque. A screw that has been tightened too loosely can cause a short circuit or malfunction. A screw that has been tightened too tightly can cause a short circuit or malfunction due to the unit breakage.
- Use crimping terminals with insulation sleeve to wire the power supply and motor.

The line voltage drop can be calculated by the following formula:

$$\text{Line voltage drop [V]} = \frac{\sqrt{3} \times \text{wire resistance [m}\Omega/\text{m}] \times \text{wiring distance [m]} \times \text{current [A]}}{1000}$$

Use a larger diameter cable when the wiring distance is long or when it is desired to decrease the voltage drop (torque reduction) in the low speed range.

## (2) Total wiring length

The overall wiring length for connection of a single motor or multiple motors should be within the value in the table below.  
200V class

Pr. 72 PWM frequency selection Setting (carrier frequency)	008	015	030	050	080	110	175 or More
1 (1kHz) or less	200m	200m	300m	500m	500m	500m	500m
2 to 15 (2kHz to 14.5kHz)	30m	100m	200m	300m	500m	500m	500m

400V class

Pr. 72 PWM frequency selection Setting (carrier frequency)	016	026	040	060	095 or More
1 (1kHz) or less	200m	200m	300m	500m	500m
2 to 15 (2kHz to 14.5kHz)	30m	100m	200m	300m	500m

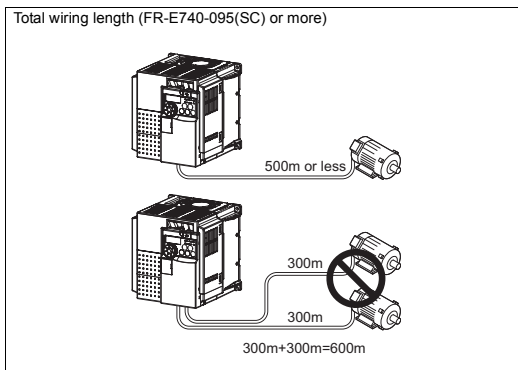

When driving a 400V class motor by the inverter, surge voltages attributable to the wiring constants may occur at the motor terminals, deteriorating the insulation of the motor. Take the following measures 1) or 2) in this case.

- 1) Use a "400V class inverter-driven insulation-enhanced motor" and set frequency in *Pr. 72 PWM frequency selection* according to wiring length

Carrier frequency	Wiring Length		
	50m or less	50m to 100m	Exceeding 100m
	14.5kHz or less	8kHz or less	2kHz or less

- 2) Connect the surge voltage suppression filter (FR-ASF-H/FR-BMF-H) on the inverter output side.

### NOTE



- Especially for long-distance wiring, the inverter may be affected by a charging current caused by the stray capacitances of the wiring, leading to a malfunction of the overcurrent protective function, fast response current limit function, or stall prevention function or a malfunction or fault of the equipment connected on the inverter output side. If malfunction of fast-response current limit function occurs, disable this function. If malfunction of stall prevention function occurs, increase the stall level. (Refer to *Pr. 22 Stall prevention operation level* and *Pr. 156 Stall prevention operation selection in Chapter 4 of the Instruction Manual*)
- Refer to *Chapter 4 of the Instruction Manual* for details of *Pr. 72 PWM frequency selection*. Refer to the manual of the option for details of surge voltage suppression filter (FR-ASF-H/FR-BMF-H).
- When using the automatic restart after instantaneous power failure function with wiring length exceeding than 100m, select without frequency search (*Pr. 162 = "1, 11"*). (Refer to *Chapter 4 of the Instruction Manual*)

### 3.3 Control circuit specifications

#### (1) Standard control circuit terminal model

##### ● Control circuit terminal layout

Terminal screw size

M3: (Terminal A, B, C)

M2: (Other than the above)

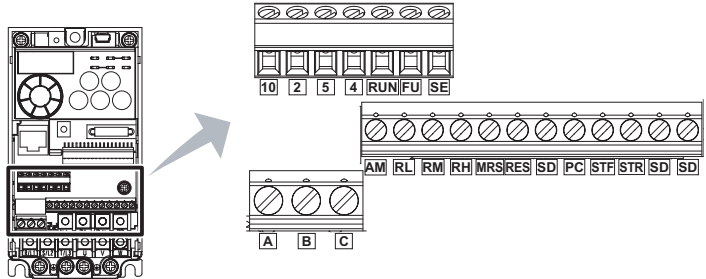

##### ● Wiring method

#### 1) Strip off the sheath of the wire of the control circuit to wire.

Strip off the sheath about the size below. If the length of the sheath peeled is too long, a short circuit may occur among neighboring wires. If the length is too short, wires might come off.

Wire the stripped wire after twisting it to prevent it from becoming loose. In addition, do not solder it. Use a blade terminal as necessary.

Wire stripping length

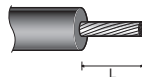

	L(mm)
Terminal A, B, C	6
Other than the above	5

Blade terminals available on the market: (as of Oct. 2008)

##### ●Phoenix Contact Co.,Ltd.

Terminal Screw Size	Wire Size (mm <sup>2</sup> )	Blade Terminal Model		Blade Terminal Crimping Tool
		With Insulation Sleeve	Without Insulation Sleeve	
<b>M3 (terminal A, B, C)</b>	0.3, 0.5	AI 0,5-6WH	A 0,5-6	CRIMPFOX ZA3
	0.75	AI 0,75-6GY	A 0,75-6	
<b>M2 (other than the above)</b>	0.3, 0.5	AI 0,5-6WH	A 0,5-6	

##### ●NICHIFU Co.,Ltd.

Terminal Screw Size	Wire Size (mm <sup>2</sup> )	Blade Terminal Product Number	Insulation Product Number	Blade Terminal Crimping Tool
<b>M3 (terminal A, B, C)</b> <b>M2 (other than the above)</b>	0.3 to 0.75	BT 0.75-7	VC 0.75	NH 67

#### 2) Loosen the terminal screw and insert the cable into the terminal.

#### 3) Tighten the screw to the specified torque.

Undertightening can cause cable disconnection or malfunction. Overtightening can cause a short circuit or malfunction due to damage to the screw or unit.

Tightening torque: 0.5N·m to 0.6N·m (terminal A, B, C)

0.22N·m to 0.25N·m (other than the above)

\* Screwdriver: ⊖Small flathead screwdriver (Tip thickness: 0.4mm/tip width: 2.5mm)

## (2) Safety stop function model

### ● Control circuit terminal layout

Recommend wire size:

0.3mm<sup>2</sup> to 0.75mm<sup>2</sup>

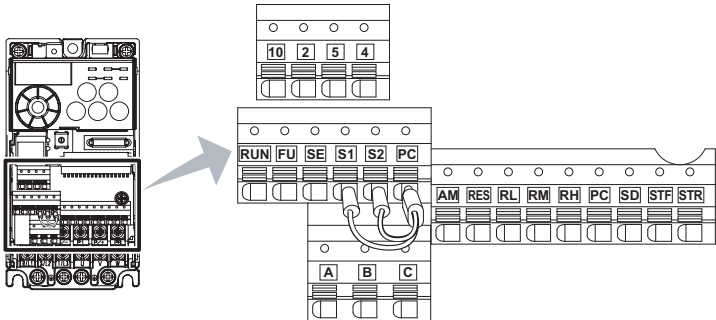

### ● Wiring method

Use a blade terminal and a wire with a sheath stripped off for the control circuit wiring. For a single wire, strip off the sheath of the wire and apply directly.

Insert the blade terminal or the single wire into a socket of the terminal.

- Strip off the sheath about the size below. If the length of the sheath peeled is too long, a short circuit may occur among neighboring wires. If the length is too short, wires might come off.  
Wire the stripped wire after twisting it to prevent it from becoming loose. In addition, do not solder it.



- Crimp the blade terminal.  
Insert wires to a blade terminal, and check that the wires come out for about 0 to 0.5 mm from a sleeve. Check the condition of the blade terminal after crimping. Do not use a blade terminal of which the crimping is inappropriate, or the face is damaged.

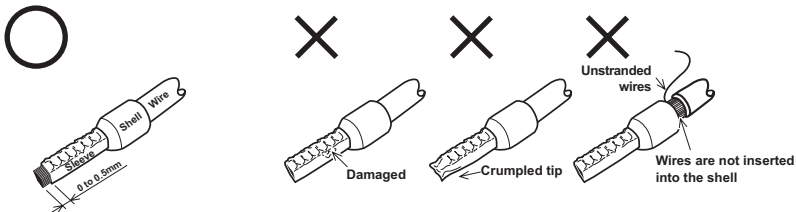

Blade terminals available on the market: (as of Oct. 2008)

#### ●Phoenix Contact Co.,Ltd.

Wire Size (mm <sup>2</sup> )	Blade Terminal Model			Blade Terminal Crimping Tool
	With Insulation Sleeve	Without Insulation Sleeve	For UL Wire *1	
0.3	AI 0,5-10WH	—	—	CRIMPFOX ZA3 (Phoenix Contact Co., Ltd.)
0.5	AI 0,5-10WH	—	AI 0,5-10WH-GB	
0.75	AI 0,75-10GY	A 0,75-10	AI 0,75-10GY-GB	
1	AI 1-10RD	A1-10	AI 1-10RD/1000GB	
1.25, 1.5	AI 1,5-10BK	A1,5-10	AI 1,5-10BK/1000GB *2	
0.75 (for two wires)	AI-TWIN 2 x 0,75-10GY	—	—	

\*1 A blade terminal with an insulation sleeve compatible with MTW wire which has a thick wire insulation

\*2 Applicable for terminal ABC.

#### ●NICHIFU Co.,Ltd.

Wire Size (mm <sup>2</sup> )	Blade Terminal Product Number	Insulation Product Number	Blade Terminal Crimping Tool
0.3 to 0.75	BT 0.75-11	VC 0.75	NH 67

3) Insert the wire into a socket.

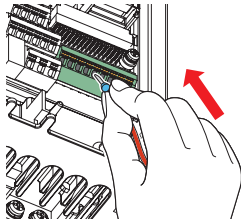

When using a single wire or stranded wire without a blade terminal, push an open/close button all the way down with a flathead screwdriver, and insert the wire.

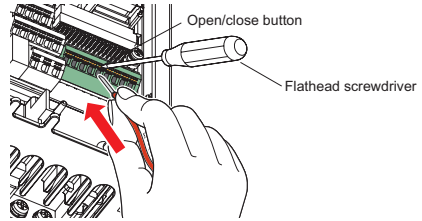

**NOTE**

- When using a stranded wire without a blade terminal, twist enough to avoid short circuit with a nearby terminals or wires.
- Place the flathead screwdriver vertical to the open/close button. In case the blade tip slips, it may cause to damage of inverter or injury.

● **Wire removal**

Pull the wire with pushing the open/close button all the way down firmly with a flathead screwdriver.

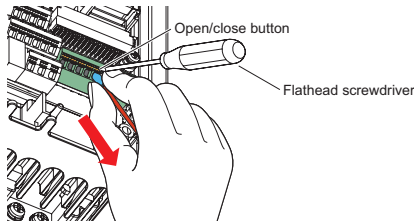

**NOTE**

- Use a small flathead screwdriver (Tip thickness: 0.4mm/tip width: 2.5mm).  
If a flathead screwdriver with a narrow tip is used, terminal block may be damaged.

Introduced products :(as of Oct. 2008)

Product	Type	Maker
Flathead screwdriver	SZF 0- 0,4 x 2,5	Phoenix Contact Co.,Ltd.

- Place the flathead screwdriver vertical to the open/close button. In case the blade tip slips, it may cause to damage of inverter or injury.

**(3) Wiring instructions**

- 1) It is recommended to use the cables of 0.3mm<sup>2</sup> to 0.75mm<sup>2</sup> gauge for connection to the control circuit terminals.
- 2) The maximum wiring length should be 30m.
- 3) Do not short terminal PC and SD. Inverter may be damaged.
- 4) Terminals PC, SE and 5 are common to the I/O signals. Do not earth them.
- 5) Use shielded or twisted cables for connection to the control circuit terminals and run them away from the main and power circuits (including the 200V relay sequence circuit).
- 6) Use two or more parallel micro-signal contacts or twin contacts to prevent contact faults when using contact inputs since the control circuit input signals are micro-currents.



Micro signal contacts

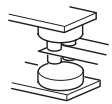

Twin contacts

- 7) Do not apply a voltage to the contact input terminals (e.g. STF) of the control circuit.
- 8) Always apply a voltage to the fault output terminals (A, B, C) via a relay coil, lamp, etc.

---

---

## 4 PRECAUTIONS FOR USE OF THE INVERTER

---

---

The FR-E700 series is a highly reliable product, but incorrect peripheral circuit making or operation/handling method may shorten the product life or damage the product.

Before starting operation, always recheck the following items.

- (1) Use crimping terminals with insulation sleeve to wire the power supply and motor.
- (2) Application of power to the output terminals (U, V, W) of the inverter will damage the inverter. Never perform such wiring.
- (3) After wiring, wire offcuts must not be left in the inverter.  
Wire offcuts can cause an alarm, failure or malfunction. Always keep the inverter clean.  
When drilling mounting holes in an enclosure etc., take care not to allow chips and other foreign matter to enter the inverter.
- (4) Use cables of the size to make a voltage drop 2% maximum.  
If the wiring distance is long between the inverter and motor, a main circuit cable voltage drop will cause the motor torque to decrease especially at the output of a low frequency.  
Refer to *page 7* for the recommended wire sizes.
- (5) The overall wiring length should be 500m maximum.  
Especially for long distance wiring, the fast-response current limit function may decrease or the equipment connected to the secondary side may malfunction or become faulty under the influence of a charging current due to the stray capacity of the wiring. Therefore, note the overall wiring length.
- (6) Electromagnetic wave interference  
The input/output (main circuit) of the inverter includes high frequency components, which may interfere with the communication devices (such as AM radios) used near the inverter. In this case, install the FR-BIF optional capacitor type filter (for use in the input side only) or FR-BSF01 common mode filter to minimize interference.
- (7) Do not install a power factor correction capacitor, surge suppressor or capacitor type filter on the inverter output side.  
This will cause the inverter to trip or the capacitor and surge suppressor to be damaged. If any of the above devices are connected, immediately remove them. (When using capacitor type filter (FR-BIF) for single-phase power input model, make sure of secure insulation of T/L3-phase, and connect to the input side of the inverter.)
- (8) For some short time after the power is switched OFF, a high voltage remains in the smoothing capacitor. When accessing the inverter for inspection, wait for at least 10 minutes after the power supply has been switched OFF, and then make sure that the voltage across the main circuit terminals P/+ and N/- of the inverter is not more than 30VDC using a tester, etc. The capacitor is charged with high voltage for some time after power off and it is dangerous.
- (9) A short circuit or earth (ground) fault on the inverter output side may damage the inverter modules.
  - Fully check the insulation resistance of the circuit prior to inverter operation since repeated short circuits caused by peripheral circuit inadequacy or an earth (ground) fault caused by wiring inadequacy or reduced motor insulation resistance may damage the inverter modules.
  - Fully check the to-earth (ground) insulation and phase to phase insulation of the inverter output side before power-on. Especially for an old motor or use in hostile atmosphere, securely check the motor insulation resistance etc.
- (10) Do not use the inverter input side magnetic contactor to start/stop the inverter.  
Always use the start signal (turn ON/OFF of STF, STR signal) to start/stop the inverter.
- (11) Across P/+ and PR terminals, connect only an external regenerative brake discharging resistor.  
Do not connect a mechanical brake.  
The brake resistor can not be connected to the FR-E720S-008(SC) or 015(SC). Leave terminals + and PR open.  
Also, never short between these terminals.

- (12) Do not apply a voltage higher than the permissible voltage to the inverter I/O signal circuits.

Application of a voltage higher than the permissible voltage to the inverter I/O signal circuits or opposite polarity may damage the I/O devices. Especially check the wiring to prevent the speed setting potentiometer from being connected incorrectly to short terminals 10-5.

- (13) Provide electrical and mechanical interlocks for MC1 and MC2 which are used for bypass operation. When the wiring is incorrect and if there is a bypass operation circuit as shown right, the inverter will be damaged when the power supply is connected to the inverter U, V, W terminals, due to arcs generated at the time of switch-over or chattering caused by a sequence error.

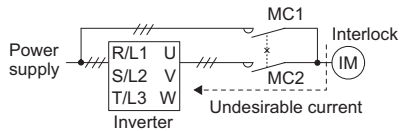

- (14) If the machine must not be restarted when power is restored after a power failure, provide a magnetic contactor in the inverter's input side and also make up a sequence which will not switch ON the start signal.  
If the start signal (start switch) remains ON after a power failure, the inverter will automatically restart as soon as the power is restored.
- (15) Instructions for overload operation

When performing operation of frequent start/stop of the inverter, rise/fall in the temperature of the transistor element of the inverter will repeat due to a repeated flow of large current, shortening the life from thermal fatigue. Since thermal fatigue is related to the amount of current, the life can be increased by reducing current at locked condition, starting current, etc. Decreasing current may increase the life. However, decreasing current will result in insufficient torque and the inverter may not start. Therefore, choose the inverter which has enough allowance for current (up to 2 rank larger in capacity).

- (16) Make sure that the specifications and rating match the system requirements.
- (17) If electromagnetic noise generated from the inverter causes frequency setting signal to fluctuate and motor rotation speed to be unstable when changing motor speed with analog signal, the following countermeasures are effective.
- Do not run the signal cables and power cables (inverter I/O cables) in parallel with each other and do not bundle them.
  - Run signal cables as far away as possible from power cables (inverter I/O cables).
  - Use shield cables as signal cables.
  - Install a ferrite core on the signal cable (Example: ZCAT3035-1330 TDK).



## 5 FAILSAFE OF THE SYSTEM WHICH USES THE INVERTER

When a fault occurs, the inverter trips to output a fault signal. However, a fault output signal may not be output at an inverter fault occurrence when the detection circuit or output circuit fails, etc. Although Mitsubishi assures best quality products, provide an interlock which uses inverter status output signals to prevent accidents such as damage to machine when the inverter fails for some reason and at the same time consider the system configuration where failsafe from outside the inverter, without using the inverter, is enabled even if the inverter fails.

(1) Interlock method which uses the inverter status output signals

By combining the inverter status output signals to provide an interlock as shown below, an inverter alarm can be detected.

No	Interlock Method	Check Method	Used Signals	Refer to Page
1)	Inverter protective function operation	Operation check of an alarm contact Circuit error detection by negative logic	Fault output signal (ALM signal)	<i>Refer to Chapter 4 of the Instruction Manual (Applied)</i>
2)	Inverter running status	Operation ready signal check	Operation ready signal (RY signal)	<i>Refer to Chapter 4 of the Instruction Manual (Applied)</i>
3)	Inverter running status	Logic check of the start signal and running signal	Start signal (STF signal, STR signal) Running signal (RUN signal)	<i>Refer to Chapter 4 of the Instruction Manual (Applied)</i>
4)	Inverter running status	Logic check of the start signal and output current	Start signal (STF signal, STR signal) Output current detection signal (Y12 signal)	<i>Refer to Chapter 4 of the Instruction Manual (Applied)</i>

(2) Backup method outside the inverter

Even if the interlock is provided by the inverter status signal, enough failsafe is not ensured depending on the failure status of the inverter itself. For example, even if the interlock is provided using the inverter fault output signal, start signal and RUN signal output, there is a case where a fault output signal is not output and RUN signal is kept output even if an inverter fault occurs.

Provide a speed detector to detect the motor speed and current detector to detect the motor current and consider the backup system such as checking up as below according to the level of importance of the system.

1) Start signal and actual operation check

Check the motor running and motor current while the start signal is input to the inverter by comparing the start signal to the inverter and detected speed of the speed detector or detected current of the current detector. Note that the motor current runs as the motor is running for the period until the motor stops since the inverter starts decelerating even if the start signal turns off. For the logic check, configure a sequence considering the inverter deceleration time. In addition, it is recommended to check the three-phase current when using the current detector.

2) Command speed and actual operation check

Check if there is no gap between the actual speed and commanded speed by comparing the inverter speed command and detected speed of the speed detector.

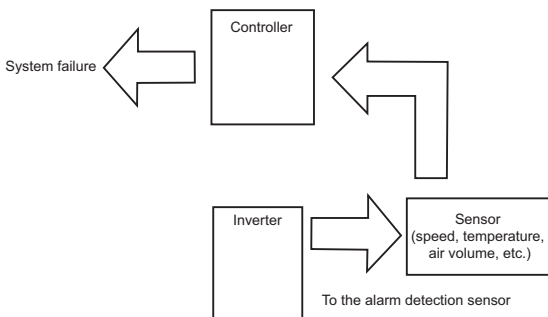

## 6 PARAMETER LIST

For simple variable-speed operation of the inverter, the initial setting of the parameters may be used. Set the necessary parameters to meet the load and operational specifications. Parameter setting, change and check can be made from the operation panel. For details of parameters, refer to the instruction manual.



### REMARKS

- ● indicates simple mode parameters. (initially set to extended mode)
- The parameters surrounded by a black border in the table allow its setting to be changed during operation even if "0" (initial value) is set in Pr. 77 Parameter write selection.
- Pr. .... Parameter number

Pr.	Name	Setting Range	Initial Value
● 0	Torque boost	0 to 30%	6/4/3/2% <sup>+1</sup>
● 1	Maximum frequency	0 to 120Hz	120Hz
● 2	Minimum frequency	0 to 120Hz	0Hz
● 3	Base frequency	0 to 400Hz	50Hz
● 4	Multi-speed setting (high speed)	0 to 400Hz	50Hz
● 5	Multi-speed setting (middle speed)	0 to 400Hz	30Hz
● 6	Multi-speed setting (low speed)	0 to 400Hz	10Hz
● 7	Acceleration time	0 to 3600/360s	5/10/15s <sup>+2</sup>
● 8	Deceleration time	0 to 3600/360s	5/10/15s <sup>+2</sup>
● 9	Electronic thermal O/L relay	0 to 500A	Rated inverter current
10	DC injection brake operation frequency	0 to 120Hz	3Hz
11	DC injection brake operation time	0 to 10s	0.5s
12	DC injection brake operation voltage	0 to 30%	6/4/2% <sup>+3</sup>
13	Starting frequency	0 to 60Hz	0.5Hz
14	Load pattern selection	0 to 3	0
15	Jog frequency	0 to 400Hz	5Hz
16	Jog acceleration/deceleration time	0 to 3600/360s	0.5s
17	MRS input selection	0, 2, 4	0
18	High speed maximum frequency	120 to 400Hz	120Hz
19	Base frequency voltage	0 to 1000V, 8888, 9999	8888
20	Acceleration/deceleration reference frequency	1 to 400Hz	50Hz
21	Acceleration/deceleration time increments	0, 1	0
22	Stall prevention operation level	0 to 200%	150%
23	Stall prevention operation level compensation factor at double speed	0 to 200%, 9999	9999
24	Multi-speed setting (speed 4)	0 to 400Hz, 9999	9999
25	Multi-speed setting (speed 5)	0 to 400Hz, 9999	9999
26	Multi-speed setting (speed 6)	0 to 400Hz, 9999	9999

Pr.	Name	Setting Range	Initial Value
27	Multi-speed setting (speed 7)	0 to 400Hz, 9999	9999
29	Acceleration/deceleration pattern selection	0, 1, 2	0
30	Regenerative function selection	0, 1, 2	0
31	Frequency jump 1A	0 to 400Hz, 9999	9999
32	Frequency jump 1B	0 to 400Hz, 9999	9999
33	Frequency jump 2A	0 to 400Hz, 9999	9999
34	Frequency jump 2B	0 to 400Hz, 9999	9999
35	Frequency jump 3A	0 to 400Hz, 9999	9999
36	Frequency jump 3B	0 to 400Hz, 9999	9999
37	Speed display	0, 0.01 to 9998	0
40	RUN key rotation direction selection	0, 1	0
41	Up-to-frequency sensitivity	0 to 100%	10%
42	Output frequency detection	0 to 400Hz	6Hz
43	Output frequency detection for reverse rotation	0 to 400Hz, 9999	9999
44	Second acceleration/deceleration time	0 to 3600/360s	5/10/15s <sup>+2</sup>
45	Second deceleration time	0 to 3600/360s, 9999	9999
46	Second torque boost	0 to 30%, 9999	9999
47	Second V/F (base frequency)	0 to 400Hz, 9999	9999
48	Second stall prevention operation current	0 to 200%, 9999	9999
51	Second electronic thermal O/L relay	0 to 500A, 9999	9999
52	DU/PU main display data selection	0, 5, 7 to 12, 14, 20, 23 to 25, 52 to 57, 61, 62, 100	0
55	Frequency monitoring reference	0 to 400Hz	50Hz
56	Current monitoring reference	0 to 500A	Rated inverter current
57	Restart coasting time	0, 0.1 to 5s, 9999	9999
58	Restart cushion time	0 to 60s	1s
59	Remote function selection	0, 1, 2, 3	0
60	Energy saving control selection	0, 9	0
61	Reference current	0 to 500A, 9999	9999

Pr.	Name	Setting Range	Initial Value
62	Reference value at acceleration	0 to 200%, 9999	9999
63	Reference value at deceleration	0 to 200%, 9999	9999
65	Retry selection	0 to 5	0
66	Stall prevention operation reduction starting frequency	0 to 400Hz	50Hz
67	Number of retries at fault occurrence	0 to 10, 101 to 110	0
68	Retry waiting time	0.1 to 360s	1s
69	Retry count display erase	0	0
70	Special regenerative brake duty	0 to 30%	0%
71	Applied motor	0, 1, 3 to 6, 13 to 16, 23, 24, 40, 43, 44, 50, 53, 54	0
72	PWM frequency selection	0 to 15	1
73	Analog input selection	0, 1, 10, 11	1
74	Input filter time constant	0 to 8	1
75	Reset selection/disconnected PU detection/PU stop selection	0 to 3, 14 to 17	14
77	Parameter write selection	0, 1, 2	0
78	Reverse rotation prevention selection	0, 1, 2	0
⊙ 79	Operation mode selection	0, 1, 2, 3, 4, 6, 7	0
80	Motor capacity	0.1 to 15kW, 9999	9999
81	Number of motor poles	2, 4, 6, 8, 10, 9999	9999
82	Motor excitation current	0 to 500A, 9999 <sup>※4</sup>	9999
83	Rated motor voltage	0 to 1000V	200V/400V <sup>※6</sup>
84	Rated motor frequency	10 to 120Hz	50Hz
89	Speed control gain (Advanced magnetic flux vector)	0 to 200%, 9999	9999
90	Motor constant (R1)	0 to 50Ω, 9999 <sup>※4</sup>	9999
91	Motor constant (R2)	0 to 50Ω, 9999 <sup>※4</sup>	9999
92	Motor constant (L1)	0 to 1000mH, 9999 <sup>※4</sup>	9999
93	Motor constant (L2)	0 to 1000mH, 9999 <sup>※4</sup>	9999
94	Motor constant (X)	0 to 100%, 9999 <sup>※4</sup>	9999
96	Auto tuning setting/status	0, 1, 11, 21	0
117	PU communication station number	0 to 31 (0 to 247)	0
118	PU communication speed	48, 96, 192, 384	192
119	PU communication stop bit length	0, 1, 10, 11	1
120	PU communication parity check	0, 1, 2	2
121	Number of PU communication retries	0 to 10, 9999	1
122	PU communication check time interval	0, 0.1 to 999.8s, 9999	0
123	PU communication waiting time setting	0 to 150ms, 9999	9999
124	PU communication CR/LF selection	0, 1, 2	1
⊙ 125	Terminal 2 frequency setting gain frequency	0 to 400Hz	50Hz

Pr.	Name	Setting Range	Initial Value
⊙ 126	Terminal 4 frequency setting gain frequency	0 to 400Hz	50Hz
127	PID control automatic switchover frequency	0 to 400Hz, 9999	9999
128	PID action selection	0, 20, 21, 40 to 43, 50, 51, 60, 61	0
129	PID proportional band	0.1 to 1000%, 9999	100%
130	PID integral time	0.1 to 3600s, 9999	1s
131	PID upper limit	0 to 100%, 9999	9999
132	PID lower limit	0 to 100%, 9999	9999
133	PID action set point	0 to 100%, 9999	9999
134	PID differential time	0.01 to 10.00s, 9999	9999
145	PU display language selection	0 to 7	1
146	Parameter for manufacturer setting. Do not set.		
147	Acceleration/deceleration time switching frequency	0 to 400Hz, 9999	9999
150	Output current detection level	0 to 200%	150%
151	Output current detection signal delay time	0 to 10s	0s
152	Zero current detection level	0 to 200%	5%
153	Zero current detection time	0 to 1s	0.5s
156	Stall prevention operation selection	0 to 31, 100, 101	0
157	OL signal output timer	0 to 25s, 9999	0s
158	AM terminal function selection	1 to 3, 5, 7 to 12, 14, 21, 24, 52, 53, 61, 62	1
⊙ 160	User group read selection	0, 1, 9999	0
161	Frequency setting/key lock operation selection	0, 1, 10, 11	0
162	Automatic restart after instantaneous power failure selection	0, 1, 10, 11	1
165	Stall prevention operation level for restart	0 to 200%	150%
168	Parameter for manufacturer setting. Do not set.		
169	Parameter for manufacturer setting. Do not set.		
170	Watt-hour meter clear	0, 10, 9999	9999
171	Operation hour meter clear	0, 9999	9999
172	User group registered display/batch clear	9999, (0 to 16)	0
173	User group registration	0 to 999, 9999	9999
174	User group clear	0 to 999, 9999	9999
178	STF terminal function selection	0 to 5, 7, 8, 10, 12, 14 to 16, 18, 24, 25, 60, 62, 65 to 67, 9999	60
179	STR terminal function selection	0 to 5, 7, 8, 10, 12, 14 to 16, 18, 24, 25, 61, 62, 65 to 67, 9999	61

Pr.	Name	Setting Range	Initial Value
180	RL terminal function selection	0 to 5, 7, 8, 10, 12, 14 to 16, 18, 24, 25, 62, 65 to 67, 9999	0
181	RM terminal function selection		1
182	RH terminal function selection		2
183 *8	MRS terminal function selection		24
184	RES terminal function selection		62
190	RUN terminal function selection	0, 1, 3, 4, 7, 8, 11 to 16, 20, 25, 26, 46, 47, 64, 80*9, 81*9, 90, 91, 93, 95, 96, 98, 99, 100, 101, 103, 104, 107, 108, 111 to 116, 120, 125, 126, 146, 147, 164, 180*9, 181*9, 190, 191, 193, 195, 196, 198, 199, 9999	0
191	FU terminal function selection		4
192	A,B,C terminal function selection	0, 1, 3, 4, 7, 8, 11 to 16, 20, 25, 26, 46, 47, 64, 80*9, 81*9, 90, 91, 95, 96, 98, 99, 100, 101, 103, 104, 107, 108, 111 to 116, 120, 125, 126, 146, 147, 164, 180*9, 181*9, 190, 191, 195, 196, 198, 199, 9999	99
232	Multi-speed setting (speed 8)	0 to 400Hz, 9999	9999
233	Multi-speed setting (speed 9)	0 to 400Hz, 9999	9999
234	Multi-speed setting (speed 10)	0 to 400Hz, 9999	9999
235	Multi-speed setting (speed 11)	0 to 400Hz, 9999	9999
236	Multi-speed setting (speed 12)	0 to 400Hz, 9999	9999
237	Multi-speed setting (speed 13)	0 to 400Hz, 9999	9999
238	Multi-speed setting (speed 14)	0 to 400Hz, 9999	9999
239	Multi-speed setting (speed 15)	0 to 400Hz, 9999	9999
240	Soft-PWM operation selection	0, 1	1
241	Analog input display unit switchover	0, 1	0
244	Cooling fan operation selection	0, 1	1
245	Rated slip	0 to 50%, 9999	9999
246	Slip compensation time constant	0.01 to 10s	0.5s
247	Constant-power range slip compensation selection	0, 9999	9999
249	Earth (ground) fault detection at start	0, 1	1
250	Stop selection	0 to 100s, 1000 to 1100s, 8888, 9999	9999

Pr.	Name	Setting Range	Initial Value
251	Output phase loss protection selection	0, 1	1
255	Life alarm status display	(0 to 15)	0
256	Inrush current limit circuit life display	(0 to 100%)	100%
257	Control circuit capacitor life display	(0 to 100%)	100%
258	Main circuit capacitor life display	(0 to 100%)	100%
259	Main circuit capacitor life measuring	0, 1 (2, 3, 8, 9)	0
261	Power failure stop selection	0, 1, 2	0
267	Terminal 4 input selection	0, 1, 2	0
268	Monitor decimal digits selection	0, 1, 9999	9999
269	Parameter for manufacturer setting. Do not set.		
270	Stop-on contact control selection	0, 1	0
275	Stop-on contact excitation current low-speed multiplying factor	0 to 300%, 9999	9999
276	PWM carrier frequency at stop-on contact	0 to 9, 9999	9999
277	Stall prevention operation current switchover	0, 1	0
278	Brake opening frequency	0 to 30Hz	3Hz
279	Brake opening current	0 to 200%	130%
280	Brake opening current detection time	0 to 2s	0.3s
281	Brake operation time at start	0 to 5s	0.3s
282	Brake operation frequency	0 to 30Hz	6Hz
283	Brake operation time at stop	0 to 5s	0.3s
286	Droop gain	0 to 100%	0%
287	Droop filter time constant	0 to 1s	0.3s
292	Automatic acceleration/ deceleration	0, 1, 7, 8, 11	0
293	Acceleration/deceleration separate selection	0 to 2	0
295	Magnitude of frequency change setting	0, 0.01, 0.1, 1, 10	0
296	Password lock level	0 to 6, 99, 100 to 106, 199, 9999	9999
297	Password lock/unlock	1000 to 9998, 9999, (0 to 5)	9999
298	Frequency search gain	0 to 32767, 9999	9999
299	Rotation direction detection selection at restarting	0, 1, 9999	0
338	Communication operation command source	0, 1	0
339	Communication speed command source	0, 1, 2	0
340	Communication startup mode selection	0, 1, 10	0
342	Communication EEPROM write selection	0, 1	0
343	Communication error count	—	0
450	Second applied motor	0, 1, 9999	9999
495	Remote output selection	0, 1, 10, 11	0
496	Remote output data 1	0 to 4095	0
497	Remote output data 2	0 to 4095	0
502	Stop mode selection at communication error	0, 1, 2, 3	0

Pr.	Name	Setting Range	Initial Value
503	Maintenance timer	0 (1 to 9998)	0
504	Maintenance timer alarm output set time	0 to 9998, 9999	9999
547	USB communication station number	0 to 31	0
548	USB communication check time interval	0 to 999.8s, 9999	9999
549	Protocol selection	0, 1	0
550	NET mode operation command source selection	0, 2, 9999	9999
551	PU mode operation command source selection	2 to 4, 9999	9999
555	Current average time	0.1 to 1.0s	1s
556	Data output mask time	0 to 20s	0s
557	Current average value monitor signal output reference current	0 to 500A	Rated inverter current
563	Energization time carrying-over times	(0 to 65535)	0
564	Operating time carrying-over times	(0 to 65535)	0
571	Holding time at a start	0 to 10s, 9999	9999
611	Acceleration time at a restart	0 to 3600s, 9999	9999
645	AM 0V adjustment	970 to 1200	1000
653	Speed smoothing control	0 to 200%	0
665	Regeneration avoidance frequency gain	0 to 200%	100
800	Control method selection	20, 30	20
859	Torque current	0 to 500A (0 to ****), 9999 *4	9999
872 *7	Input phase loss protection selection	0, 1	1
882	Regeneration avoidance operation selection	0, 1, 2	0
883	Regeneration avoidance operation level	300 to 800V	400VDC/ 780VDC *6
885	Regeneration avoidance compensation frequency limit value	0 to 10Hz, 9999	6Hz
886	Regeneration avoidance voltage gain	0 to 200%	100%
888	Free parameter 1	0 to 9999	9999
889	Free parameter 2	0 to 9999	9999
C1 (901) *5	AM terminal calibration	-	-
C2 (902) *5	Terminal 2 frequency setting bias frequency	0 to 400Hz	0Hz
C3 (902) *5	Terminal 2 frequency setting bias	0 to 300%	0%
125 (903) *5	Terminal 2 frequency setting gain frequency	0 to 400Hz	50Hz
C4 (903) *5	Terminal 2 frequency setting gain	0 to 300%	100%

Pr.	Name	Setting Range	Initial Value
C5 (904) *5	Terminal 4 frequency setting bias frequency	0 to 400Hz	0Hz
C6 (904) *5	Terminal 4 frequency setting bias	0 to 300%	20%
126 (905) *5	Terminal 4 frequency setting gain frequency	0 to 400Hz	50Hz
C7 (905) *5	Terminal 4 frequency setting gain	0 to 300%	100%
C22 (922) *5	Parameter for manufacturer setting. Do not set.		
C23 (922) *5			
C24 (923) *5			
C25 (923) *5			
990	PU buzzer control	0, 1	1
991	PU contrast adjustment	0 to 63	58
Pr.CL	Parameter clear	0, 1	0
ALLC	All parameter clear	0, 1	0
Er.CL	Faults history clear	0, 1	0
Pr.CH	Initial value change list	—	—

\*1 Differ according to capacities.

6%: FR-E740-026(SC) or less, FR-E720S-050(SC) or less  
 4%: FR-E740-040(SC) to 095(SC), FR-E720S-080(SC) and 110(SC)  
 3%: FR-E740-120(SC) and 170(SC)  
 2%: FR-E740-230(SC) and 300(SC)

\*2 Differ according to capacities.

5s: FR-E740-095(SC) or less, FR-E720S-008(SC) to 110(SC)  
 10s: FR-E740-120(SC) and 170(SC)  
 15s: FR-E740-230(SC) and 300(SC)

\*3 Differ according to capacities.

6%: FR-E720S-008(SC) and 015(SC)  
 4%: FR-E740-016(SC) to 170(SC), FR-E720S-030(SC) to 110(SC)  
 2%: FR-E740-230(SC) and 300(SC)

\*4 The range differs according to the Pr. 71 setting.

\*5 The parameter number in parentheses is the one for use with the operation panel (FR-PA02) for the FR-E500 series or parameter unit (FR-PU04/FR-PU07).

\*6 The initial value differs according to the voltage class. (200V class/400V class)

\*7 Available only for the three-phase power input specification model.

\*8 For the safety stop function model, this setting is active only during the communication operation.

\*9 These parameters can be set only in the safety stop function model.

---

---

# 7 TROUBLESHOOTING

---

---

When a fault occurs in the inverter, the inverter trips and the PU display automatically changes to any of the following fault or alarm indications.

If the fault does not correspond to any of the following faults or if you have any other problem, please contact your sales representative.

- Retention of fault output signal...When the magnetic contactor (MC) provided on the input side of the inverter is opened when a fault occurs, the inverter's control power will be lost and the fault output will not be held.
- Fault or alarm indication.....When a fault or alarm occurs, the operation panel display automatically switches to the fault or alarm indication.
- Resetting method.....When a fault occurs, the inverter output is kept stopped. Unless reset, therefore, the inverter cannot restart.
- When any fault occurs, take the appropriate corrective action, then reset the inverter, and resume operation.  
Not doing so may lead to the inverter fault and damage.

Inverter fault or alarm indications are roughly categorized as below.

- (1) Error message  
A message regarding operational fault and setting fault by the operation panel and parameter unit (FR-PU04 /FR-PU07) is displayed. The inverter does not trip.
- (2) Warning  
The inverter does not trip even when a warning is displayed. However, failure to take appropriate measures will lead to a fault.
- (3) Alarm  
The inverter does not trip. You can also output an alarm signal by making parameter setting.
- (4) Fault  
When a fault occurs, the inverter trips and a fault signal is output.

---

## 7.1 Reset method of protective function

---

### (1) Resetting the inverter

The inverter can be reset by performing any of the following operations. Note that the internal thermal integrated value of the electronic thermal relay function and the number of retries are cleared (erased) by resetting the inverter.

Inverter recovers about 1s after reset is released.

Operation 1: ..... Using the operation panel, press  to reset the inverter.

(This may only be performed when a fault occurs)



Operation 2: ..... Turn ON the reset signal (RES) for more than 0.1s. (If the RES signal is kept ON, "Err." appears (flickers) to indicate that the inverter is in a reset status.)

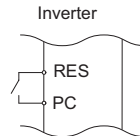

Operation 3: ..... Switch power OFF once. After the indicator of the operation panel turns OFF, switch it ON again.

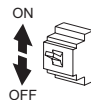

## 7.2 List of fault or alarm indications

Operation Panel Indication		Name	
Error message	E---	E---	Faults history
	HOLD	HOLD	Operation panel lock
	LOCD	LOCD	Password locked
	Er1 to Er4	Er1 to 4	Parameter write error
	Err.	Err.	Inverter reset
Warning	OL	OL	Stall prevention (overcurrent)
	oL	oL	Stall prevention (overvoltage)
	rb	RB	Regenerative brake prealarm
	TH	TH	Electronic thermal relay function prealarm
	PS	PS	PU stop
	MT	MT	Maintenance signal output
	UV	UV	Undervoltage
	SA	SA *2	Safety stop
Alarm	F <sub>n</sub>	FN	Fan alarm
Fault	E.OC1	E.OC1	Overcurrent trip during acceleration
	E.OC2	E.OC2	Overcurrent trip during constant speed
	E.OC3	E.OC3	Overcurrent trip during deceleration or stop
	E.OV1	E.OV1	Regenerative overvoltage trip during acceleration
	E.OV2	E.OV2	Regenerative overvoltage trip during constant speed
	E.OV3	E.OV3	Regenerative overvoltage trip during deceleration or stop
	E.THT	E.THT	Inverter overload trip (electronic thermal relay function)
	E.THM	E.THM	Motor overload trip (electronic thermal relay function)
	E.FIN	E.FIN	Heatsink overheat

Operation Panel Indication		Name
E.ILF	E.ILF *1	Input phase loss
E.OLT	E.OLT	Stall prevention stop
E. bE	E. BE	Brake transistor alarm detection
E. GF	E.GF	Output side earth (ground) fault overcurrent at start
E. LF	E.LF	Output phase loss
E.OHT	E.OHT	External thermal relay operation
E.OPT	E.OPT	Option fault
E.OP1	E.OP1	Communication option fault
E. 1	E. 1	Option fault
E. PE	E. PE	Parameter storage device fault
E.PE2	E.PE2 *1	Internal board fault
E.PUE	E.PUE	PU disconnection
E. RET	E.RET	Retry count excess
E. 5/	E. 5/	CPU fault
E. 6/	E. 6/	
E. 7/	E. 7/	
E.CPU	E.CPU	
E.IOH	E.IOH *1	Inrush current limit circuit fault
E.AIE	E.AIE *1	Analog input fault
E.USB	E. USB *1	USB communication fault
E.MB4 to E.MB7	E.MB4 to E.MB7	Brake sequence fault
E.SAF	E. SAF *1, *2	Safety circuit fault
E. 13	E. 13	Internal circuit fault

\*1 If a fault occurs when using with the FR-PU04, "Fault 14" is displayed on the FR-PU04.

\*2 This is displayed only for the safety stop function model.

## Appendix 1 Instructions for Compliance with the EU Directives

The EU Directives are issued to standardize different national regulations of the EU Member States and to facilitate free movement of the equipment, whose safety is ensured, in the EU territory.

Since 1996, compliance with the EMC Directive that is one of the EU Directives has been legally required. Since 1997, compliance with the Low Voltage Directive, another EU Directive, has been also legally required. When a manufacturer confirms its equipment to be compliant with the EMC Directive and the Low Voltage Directive, the manufacturer must declare the conformity and affix the CE marking.

### ● The authorized representative in the EU

The authorized representative in the EU is shown below.

Name: Mitsubishi Electric Europe B.V.

Address: Gothaer Strasse 8, 40880 Ratingen, Germany

### ● Note

We declare that this inverter, when equipped with the dedicated EMC filter, conforms with the EMC Directive in industrial environments and affix the CE marking on the inverter. When using the inverter in a residential area, take appropriate measures and ensure the conformity of the inverter used in the residential area.

### (1) EMC Directive

We declare that this inverter, when equipped with the EMC Directive compliant EMC filter, conforms with the EMC Directive and affix the CE marking on the inverter.

- EMC Directive: 2004/108/EC
- Standard(s): EN61800-3:2004 (Second environment / PDS Category "C3")

#### Note: First environment

Environment including residential buildings. Includes building directly connected without a transformer to the low voltage power supply network which supplies power to residential buildings.

#### Second environment

Environment including all buildings except buildings directly connected without a transformer to the lower voltage power supply network which supplies power to residential buildings.

### ● Note

- \* Set the EMC Directive compliant EMC filter to the inverter. Insert line noise filters and ferrite cores to the power and control cables as required.
- \* Connect the inverter to an earthed power supply.
- \* Install a motor, the EMC Directive compliant EMC filter, and a control cable according to the instructions written in the EMC Installation Guidelines (BCN-A21041-204). (Please contact your sales representative for the EMC Installation Guidelines.)
- \* The cable length between the inverter and the motor is 5m maximum.
- \* Confirm that the final integrated system with the inverter conforms with the EMC Directive.



## (2) Low Voltage Directive

We have self-confirmed our inverters as products compliant to the Low Voltage Directive (Conforming standard EN 61800-5-1) and affix the CE marking on the inverters.

### ● Outline of instructions

- \* Do not use an earth leakage circuit breaker as an electric shock protector without connecting the equipment to the earth. Connect the equipment to the earth securely.
- \* Wire the earth (ground) terminal independently. (Do not connect two or more cables to one terminal.)
- \* Use the cable sizes on *page 7* under the following conditions.
  - Surrounding air temperature: 40°C maximum
 If conditions are different from above, select appropriate wire according to EN60204 ANNEX C TABLE 5.
- \* Use a tinned (plating should not include zinc) crimping terminal to connect the earth cable. When tightening the screw, be careful not to damage the threads.
- For use as a product compliant with the Low Voltage Directive, use PVC cable on *page 7*.
- \* Use the moulded case circuit breaker and magnetic contactor which conform to the EN or IEC Standard.
- \* When using an earth leakage circuit breaker, use a residual current operated protective device (RCD) of type B (breaker which can detect both AC and DC). If not, provide double or reinforced insulation between the inverter and other equipment, or put a transformer between the main power supply and inverter.
- \* Use the inverter under the conditions of overvoltage category II (usable regardless of the earth (ground) condition of the power supply), overvoltage category III (usable with the earthed-neutral system power supply, 400V class only) specified in IEC664.
- To use the inverter under the conditions of pollution degree 3, install it in the enclosure of IP54 or higher.
- To use the inverter outside of an enclosure in an enclosure of pollution degree 2, fix a fan cover with fan cover fixing screws enclosed.

FR-E740-095(SC) or less  
FR-E720S-050(SC) to 110(SC)

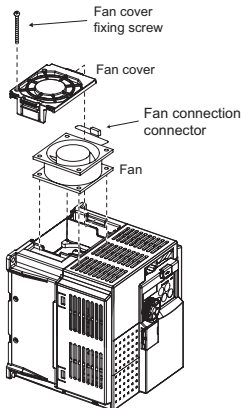

Example for FR-E740-095

FR-E740-120(SC) or more

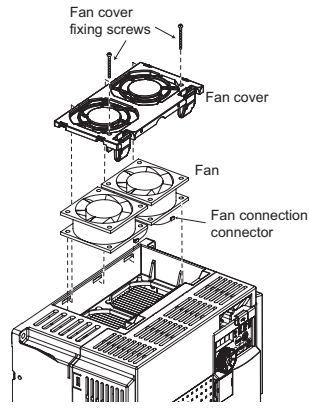

Example for FR-E740-120

Note, the protection structure of the Inverter units is considered to be an IP00.

- \* On the input and output of the inverter, use cables of the type and size set forth in EN60204 Appendix C.
- \* The operating capacity of the relay outputs (terminal symbols A, B, C) should be 30VDC, 0.3A. (Relay output has basic isolation from the inverter internal circuit.)
- \* Control circuit terminals on *page 4* are safely isolated from the main circuit.
- \* Environment

	Running	In Storage	During Transportation
Surrounding Air Temperature	-10°C to +50°C	-20°C to +65°C	-20°C to +65°C
Humidity	90% RH or less (non-condensing)	90% RH or less (non-condensing)	90% RH or less (non-condensing)
Maximum Altitude	1000m	1000m	10000m

Details are given in the technical information "Low Voltage Directive Conformance Guide" (BCN-A21041-203). (Please contact your sales representative for the manual.)

\* Select a UL and cUL certified fuse with Class T fuse equivalent cut-off speed or faster with the appropriate rating for branch circuit protection, or a UL489 molded case circuit breaker (MCCB) in accordance with the table below.

FR-E740-□□□(SC)-EC		016	026	040	060	095	120	170	230	300
Rated fuse voltage(V)		480V or more								
Fuse Maximum allowable rating (A)*	Without power factor improving reactor	6	10	15	20	30	40	70	80	90
	With power factor improving reactor	6	10	10	15	25	35	60	70	90
Molded case circuit breaker (MCCB) Maximum allowable rating (A)*		15	15	15	15	20	30	40	50	70

FR-E720S-□□□(SC)-EC		008	015	030	050	080	110
Rated fuse voltage(V)		240V or more					
Fuse Maximum allowable rating (A)*	Without power factor improving reactor	15	20	20	30	40	60
	With power factor improving reactor	15	20	20	20	30	50
Molded case circuit breaker (MCCB) Maximum allowable rating (A)*		15	15	15	20	25	40

\* Maximum allowable rating by US National Electrical Code. Exact size must be chosen for each installation.

\* When using the electronic thermal relay function as motor overload protection, set the rated motor current to Pr: 9 Electronic thermal O/L relay.

### Electronic thermal relay function operation characteristic

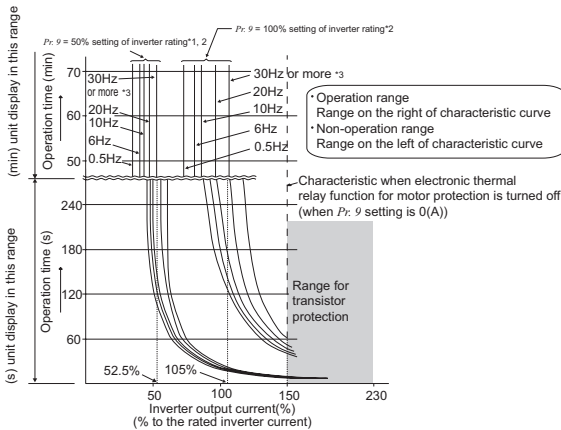

This function detects the overload (overheat) of the motor, stops the operation of the inverter's output transistor, and stops the output.

(The operation characteristic is shown on the left)

When using the Mitsubishi constant-torque motor

- 1) Set "1" or any of "13" to "16", "50", "53", "54" in Pr: 71. (This provides a 100% continuous torque characteristic in the low-speed range.)
- 2) Set the rated current of the motor in Pr: 9.

- \*1 When 50% of the inverter rated output current (current value) is set in Pr: 9
- \*2 The % value denotes the percentage to the inverter rated output current. It is not the percentage to the motor rated current.
- \*3 When you set the electronic thermal relay function dedicated to the Mitsubishi constant-torque motor, this characteristic curve applies to operation at 6Hz or higher.



### Note

- Protective function by electronic thermal relay function is reset by inverter power reset and reset signal input. Avoid unnecessary reset and power-OFF.
- When multiple motors are operated by a single inverter, protection cannot be provided by the electronic thermal relay function. Install an external thermal relay to each motor.
- When the difference between the inverter and motor capacities is large and the setting is small, the protective characteristics of the electronic thermal relay function will be deteriorated. In this case, use an external thermal relay.
- A special motor cannot be protected by the electronic thermal relay function. Use the external thermal relay.
- If electric thermal is set to 5% or lower of the inverter rated current, electronic thermal may not operate.

\* Short circuit current ratings

•200V class

Suitable For Use in A Circuit Capable of Delivering Not More Than 5 kA rms Symmetrical Amperes, 264 V Maximum.

•400V class

Suitable For Use in A Circuit Capable of Delivering Not More Than 5 kA rms Symmetrical Amperes, 528 V Maximum.

## Appendix 2 Instructions for UL and cUL

(Standard to comply with: UL 508C, CSA C22.2 No. 14)

### 1. General Precaution

The bus capacitor discharge time is 10 minutes. Before starting wiring or inspection, switch power off, wait for more than 10 minutes, and check for residual voltage between terminal P/+ and N/- with a meter etc., to avoid a hazard of electrical shock.

### 2. Installation

The below types of inverter have been approved as products for use in enclosure and approval tests were conducted under the following conditions. Design the enclosure so that the surrounding air temperature, humidity and ambience of the inverter will satisfy the specifications (*Refer to page 2*).

#### Wiring protection

Integral solid state short circuit protection does not provide branch circuit protection. Branch circuit protection must be provided in accordance with the National Electrical Code for the U.S. or the Canadian Electrical Code for Canada and any additional codes. As specified, UL Class T fuses or any faster acting fuse with the appropriate rating or Listed UL 489 Molded Case Circuit Breaker (MCCB) must be employed. (*Refer to page 23*)

### 3. Short circuit ratings

#### • 200V class

Suitable For Use in A Circuit Capable of Delivering Not More Than 100 kA rms Symmetrical Amperes, 264 V Maximum.

#### • 400V class

Suitable For Use in A Circuit Capable of Delivering Not More Than 100 kA rms Symmetrical Amperes, 528 V Maximum.

### 4. Wiring

For wiring the input (R/L1, S/L2, T/L3) and output (U, V, W) terminals of the inverter, use the UL Listed copper, stranded wires (rated at 75°C) and round crimping terminals. Crimp the crimping terminals with the crimping tool recommended by the terminal maker.

### 5. Motor overload protection

When using the electronic thermal relay function as motor overload protection, set the rated motor current to Pr. 9 "Electronic thermal O/L relay". (*Refer to page 23*)



#### NOTE

- Protective function by electronic thermal relay function is reset by inverter power reset and reset signal input. Avoid unnecessary reset and power-OFF.
- When multiple motors are operated by a single inverter, protection cannot be provided by the electronic thermal relay function. Install an external thermal relay to each motor.
- When the difference between the inverter and motor capacities is large and the setting is small, the protective characteristics of the electronic thermal relay function will be deteriorated. In this case, use an external thermal relay.
- A special motor cannot be protected by the electronic thermal relay function. Use the external thermal relay.
- If electric thermal is set to 5% or lower of the inverter rated current, electronic thermal may not operate.



#### REMARKS

- Safety stop function is not certified by UL for the Safety stop function model.

REVISIONS

\*The manual number is given on the bottom left of the back cover.

Print Date	*Manual Number	Revision
Oct. 2007	IB-0600335ENG-A	First edition
Dec. 2007	IB-0600335ENG-B	<b>Addition</b> • FR-E740-230, 300-EC
Oct. 2008	IB-0600335ENG-C	<b>Addition</b> • FR-E720S-008 to 110-EC
Aug. 2010	IB-0600335ENG-D	<b>Addition</b> • Pr. 296 Password lock level • Pr. 297 Password lock/unlock • Password locked (LOCd) • Option fault (E.OPT) • Safety stop function model • FR-E740-016SC to 300SC-EC • FR-E720S-008SC to 110SC-EC • Setting values "80, 81, 180, 181" of Pr. 190 to Pr. 192 (Output terminal function selection) • Safety stop (SA) • Safety circuit fault (E.SAF) <b>Partial modification</b> • Appendix1 Instructions for the EU Directive

 **For Maximum Safety**

- Mitsubishi inverters are not designed or manufactured to be used in equipment or systems in situations that can affect or endanger human life.
- When considering this product for operation in special applications such as machinery or systems used in passenger transportation, medical, aerospace, atomic power, electric power, or submarine repeating applications, please contact your nearest Mitsubishi sales representative.
- Although this product was manufactured under conditions of strict quality control, you are strongly advised to install safety devices to prevent serious accidents when it is used in facilities where breakdowns of the product are likely to cause a serious accident.
- Please do not use this product for loads other than three-phase induction motors.

■ Before using this CD-ROM

- The copyright and other rights of this CD-ROM all belong to Mitsubishi Electric Corporation.
- No part of this CD-ROM may be copied or reproduced without the permission of Mitsubishi Electric Corporation.
- Specifications of this CD-ROM are subject to change for modification without notice.
- We are not responsible for any damages and lost earnings, etc. from use of this CD-ROM.
- Microsoft, Windows, Microsoft WindowsNT, Internet Explorer are registered trademarks of Microsoft Corporation in the United States and/or other countries. Adobe and Acrobat are registered trademarks of Adobe Systems Incorporated. Pentium is a registered trademark of Intel Corporation of the United States and/or other countries. Other company and product names herein are the trademarks and registered trademarks of their respective owners.
- Warranty
  - We do not provide a warranty against defects in this CD-ROM and related documents.
- Acrobat Reader
  - For use of Acrobat Reader, please follow use conditions established by Adobe Systems Incorporated.

Warning: This is a personal computer dedicated CD-ROM. Do not attempt to play it on ordinary audio devices. The loud volume may damage hearing and speakers.

■ When playing this CD-ROM on Windows OS

- ◆ Operating environment
  - The following system is required to read instruction manuals contained in this CD-ROM.

Item	Specifications
OS	Microsoft Windows 95 OSR 2.0, Windows 98 Second Edition, Windows Millennium Edition, Windows NT 4.0 with Service Pack 6, Windows 2000 with Service Pack 2, Windows XP Professional or Home Edition, Windows XP Tablet PC Edition
CPU	Intel Pentium processor
Memory	64MB of RAM
Hard disk	24MB of available hard-disk space
CD-ROM drive	Double speed or more (more than quadruple speed is recommended)
Monitor	800x600 dot or more
Application	Acrobat Reader 4.05 or more Internet Explorer 6.0 or more

- ◆ Operating method of this CD-ROM

How to read instruction manuals

- Step 1. Start Windows and place this CD-ROM in the CD-ROM drive.
- Step 2. "FR-E700 series documents" HTML automatically opens.
- Step 3. Choose your language by a language choice menu of the page left edge.
- Step 4. Click a manual you want to read in the "INSTRUCTION MANUAL" list.
- Step 5. PDF manual you clicked opens.

\* Manual opening of this CD-ROM

- Step 1. Start Windows and place this CD-ROM in the CD-ROM drive.
- Step 2. Select a CD-ROM drive (example: D drive) of "My computer" and click the right mouse button. Then, click "open" in the context menu.
- Step 3. Open "index.html" in the opened folder.
- Step 4. "FR-E700 series documents" HTML opens. Operates according to the steps from "Step 3" of "How to read instruction manuals"

- PDF data of the instruction manual are stored in "MANUAL" folder on this CD-ROM.

HEADQUARTERS		EUROPEAN REPRESENTATIVES		EUROPEAN REPRESENTATIVES		EUROPEAN REPRESENTATIVES			
<b>MITSUBISHI ELECTRIC EUROPE B.V.</b> German Branch Gothaer Straße 8 <b>D-40880 Ratingen</b> Phone: +49 (0) 21 02 / 486-0 Hotline: +49 2102 1805 000-765 /-766 Fax: +49 (0) 21 02 / 4 86-1 12 0 e mail: mega-mail@meg.mee.com www.mitsubishi-automation.com		<b>GEVA AUSTRIA</b> Wiener Straße 89 <b>A-2500 Baden</b> Phone: +43 (0) 2252 / 85 55 20 Fax: +43 (0) 2252 / 488 60 e mail: office@geva.co.at		<b>GETRONICS B.V. BELGIUM</b> Control Systems Pontbeeklaan 43 <b>B-1731 Asse-Zellik</b> Phone: +32 (0) 2 / 4 67 17 51 Fax: +32 (0) 2 / 4 67 17 45 e mail: infoautomation@getronics.com		<b>MITSUBISHI ELECTRIC IRELAND</b> EUROPE B.V.-Irish Branch Westgate Business Park Ballymount <b>IRL-Dublin 24</b> Phone: +353 (0) 1 / 419 88 00 Fax: +353 (0) 1 / 419 88 90 e mail: sales.info@meuk.mee.com		<b>BEIJER ELECTRONICS AB SWEDEN</b> Box 426 <b>S-20123 Malmö</b> Phone: +46 (0) 40 / 35 86 00 Fax: +46 (0) 40 / 93 23 02 e mail: _____	
<b>MITSUBISHI ELECTRIC FRANCE</b> 25 Boulevard des Bouvets <b>F-92741 Nanterre Cedex</b> Phone: +33 1 55 68 55 68 Fax: +33 1 49 01 07 25 e mail: factory.automation@fra.mee.com		<b>TELECON CO. BULGARIA</b> 4. A. Ljapchev Blvd. <b>BG-1756 Sofia</b> Phone: +359 92 / 97 44 05 8 Fax: +359 92 / 97 44 06 1 e mail: _____		<b>ALFATRADE LTD. MALTA</b> 99 Paola Hill <b>Paola PLA 08</b> Phone: +356 / 697816 Fax: +356 / 697817 e mail: paul.licari@alfatrx.com		<b>ECONOTEC AG SWITZERLAND</b> Postfach 282 <b>CH-8309 Nürensdorf</b> Phone: +41 (0) 1 / 838 48 11 Fax: +41 (0) 1 / 838 48 12 e mail: _____			
<b>MITSUBISHI ELECTRIC ITALY</b> Italian Branch C.D. Colleoni-P. Perseo Ing. 2 Via Paracelso 12 <b>I-20041 Agrate Brianza (MI)</b> Phone: +39 (0) 39 / 60 53 1 Fax: +39 (0) 39 / 60 53 312 e mail: factory.automation@it.mee.com		<b>AutoControl CZECHIA</b> Control Systems s.r.o. Nemocnici 12 <b>CZ-70200 Ostrava 2</b> Phone: +420 (0) 69 / 615 21 11 Fax: +420 (0) 69 / 615 21 12 e mail: _____		<b>NETHERLANDS</b> Getronics bv Control Systems Donauweg 10 <b>NL-1043 AJ-Amsterdam</b> Phone: +31 (0) 20 / 586 15 92 Fax: +31 (0) 20 / 586 19 27 e mail: infoautomation@getronics.com		<b>GTS TURKEY</b> Darülaceze Cad. No. 43A KAT: 2 <b>TR-80270 Okmeydani-Istanbul</b> Phone: +90 (0) 212 / 320 1640 Fax: +90 (0) 212 / 320 1649 e mail: _____			
<b>MITSUBISHI ELECTRIC SPAIN</b> EUROPE B.V. Pol. Ind. Can Magi-C. Calle Joan Buscailá, 2-4 AC 420 <b>E-08190 Sant Cugat del Vallés</b> Phone: +34 (9) 3 / 565 31 31 Fax: +34 (9) 3 / 589 29 48		<b>louis poulsen DENMARK</b> industri & automation Geminivvej 32 <b>DK-2670 Greve</b> Phone: +45 (0) 43 / 95 95 95 Fax: +45 (0) 43 / 95 95 91 e mail: lopia@lpmail.com		<b>MPL Technology SP.Z.o.o. POLAND</b> ul.Wroclawska 53 <b>PL-30-011 Kraków</b> Phone: +48 (0) 12 / 632 28 85 Fax: +48 (0) 12 / 632 47 82 e mail: krakow@mpl.com.pl		<b>RUSSIA</b> MITSUBISHI ELECTRIC EUROPE B.V. 12/1 Gonchamaya St. suite 3C <b>RUS-109240 Moscow</b> Phone: +7 (0) 95 / 915-8624/02 Fax: +7 (0) 95 / 915-8603 e mail: _____			
<b>MITSUBISHI ELECTRIC UK</b> EUROPE B.V. UK Branch Travellers Lane <b>Hatfield, Hertfordshire, AL10 8 XB</b> Phone: +44 (0) 1707 / 27 61 00 Fax: +44 (0) 1707 / 27 86 95		<b>UTU Elektrotehnika AS ESTONIA</b> Pärnu mnt. 1601 <b>EE-10621 Tallinn</b> Phone: +372 6 / 51 72 80 Fax: +372 6 / 51 72 88 e mail: utu@utu.ee		<b>SIRIUS TRADING &amp; SERVICES srl ROMANIA</b> Bd. Ghica nr. 112, Bl. 41 <b>RO-72335 Bucuresti 2</b> Phone: +40 (0) 1 / 210 55 11 Fax: +40 (0) 1 / 210 55 11 e mail: sirius_t_s@fx.ro		<b>STC Drive Technique RUSSIA</b> Poslannikov per., 9, str. 1 <b>RUS-107005 Moscow</b> Phone: +7 (0) 95 / 786 21 00 Fax: +7 (0) 95 / 786 21 01 e mail: _____			
<b>MITSUBISHI ELECTRIC JAPAN CORPORATION</b> Tokyo Bldg. 2-7-3 Marunouchi Chiyoda-Ku <b>Tokyo 100-8310</b> Phone: +81 (0) 3 / 32 18 31 76 Fax: +81 (0) 3 / 32 18 24 22		<b>URHO TUOMINEN OY FINLAND</b> Hevoshaankatu 3 <b>FIN-28600 Pori</b> Phone: +358 (0) 2 / 55 08 00 Fax: +358 (0) 2 / 55 088 41 e mail: _____		<b>SLOVAKIA</b> ACP AUTOCOMP a.s. Chalupkova 7 <b>SK-81109 Bratislava</b> Phone: +421 (0) 7 592 22 54 Fax: +421 (0) 7 592 22 48 e mail: _____		<b>UKRAINE</b> JV-CSC Automation 15, M. Raszkovoi St., Floor 10, Office 1010 <b>U-02002 Kiev</b> Phone: +380 (4) 4 / 238 83 16 Fax: +380 (4) 4 / 238 83 17 e-Mail: mkl@csc-a.kiev.ua			
<b>MITSUBISHI ELECTRIC USA AUTOMATION</b> 500 Corporate Woods Parkway <b>Vernon Hills, Illinois 60061</b> Phone: +1 (0) 847 / 478 21 00 Fax: +1 (0) 847 / 478 03 27		<b>UTECO A.B.E.E. GREECE</b> 5. Mavrogenous Str. <b>GR-18542 Piraeus</b> Phone: +30 (0) 1 / 42 10 050 Fax: +30 (0) 1 / 42 12 033 e mail: uteco@uteco.gr		<b>SLOVENIA</b> INEA d.o.o. Ljubljanska 80 <b>SI-1230 Domžale</b> Phone: +386 (0) 17 21 80 00 Fax: +386 (0) 17 24 16 72 e mail: inea@inea.si		<b>MIDDLE EAST REPRESENTATIVE</b> <b>SHERF Motion Techn. LTD ISRAEL</b> Rehov Hamerkava 19 <b>IL-58851 Holon</b> Phone: +972 (0) 3 / 559 54 62 Fax: +972 (0) 3 / 556 01 82 e mail: _____			

# **MITSUBISHI ELECTRIC CORPORATION**

HEAD OFFICE: TOKYO BUILDING 2-7-3, MARUNOUCHI, CHIYODA-KU, TOKYO 100-8310, JAPAN